

**OWNERS MANUAL**

**...with installation instructions**

# **Banks PowerPack® System**

**INCLUDING**

- **STINGER®-PLUS**
- **STINGER®**
- **GIT-KIT™**

**1999-2003 Ford Power Stroke 7.3L  
Turbo Diesel  
For 3 1/2" Exhaust Only**

(with OttoMInd™ Engine Calibration Module)

THIS MANUAL IS FOR USE WITH:

**GIT KIT SYSTEM:** 47401

**STINGER SYSTEMS:** 47411, 47413, 47431, 47433,  
47451, 47453

**STINGER-PLUS SYSTEMS:** 47416, 47418, 47436,  
47438, 47456, 47458

**POWERPACK SYSTEMS:** 47421, 47423, 47441,  
47443, 47461, 47463

Gale Banks Engineering  
546 Duggan Avenue • Azusa, CA 91702  
(626) 969-9600 • Fax (626) 334-1743

Product Information & Sales: (800) 438-7693

**[bankspower.com](http://bankspower.com)**

The logo for Banks Engineering, featuring the word "BANKS" in a bold, italicized, sans-serif font. The letters are black with a white outline, and the entire logo is tilted upwards to the right.

# Also Available from Banks Power for '99-03 Ford 7.3L

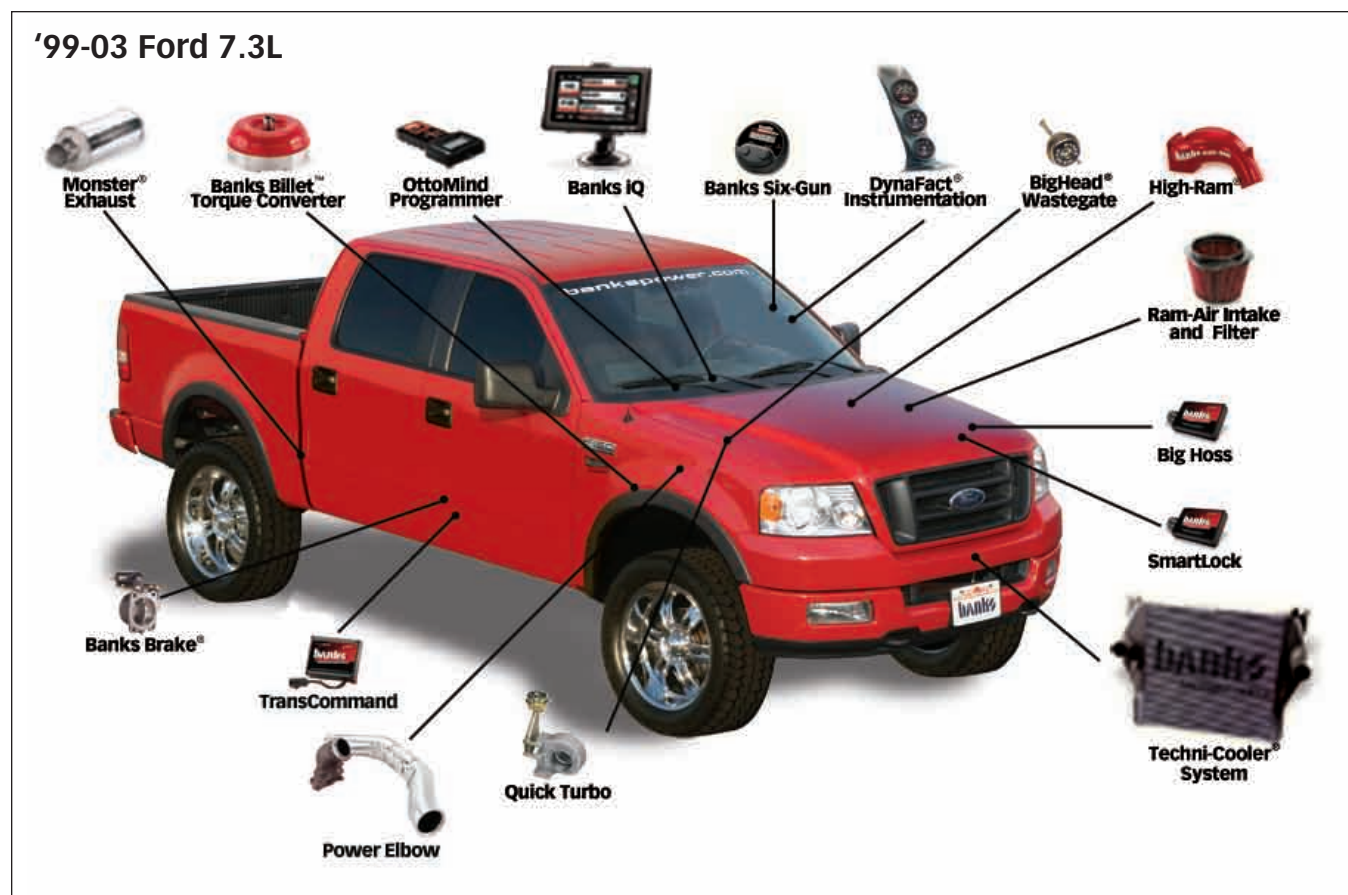

## **Banks Power Elbow** (P/N 48651-48652, 48661-48663)

- Reduces stock outlet and pipe backpressure

## **Banks Monster® Exhaust System Sport** (P/N 48789) **Single and Dual** (P/N 48653-48660, 47391-47399)

- Increases exhaust flow, cuts backpressure, lowers exhaust gas temperatures (EGTs) and increases power.

## **Banks Ram-Air Intake System** (P/N 96885)

- Increases your airflow over stock.
- Adds power, improves fuel economy, lowers EGTs and reduces smoke.

## **Banks Techni-Cooler® System** (P/N 25971-25973)

- Provides increased air flow to the engine by increasing air density for more increased power, lower EGTs and improved fuel economy.

## **Banks Brake** (P/N 55202-55207)

- Increases the stopping power of your truck and extends the service life of your brakes

## **Banks SmartLock** (P/N 55266)

- Reduces wear on transmission
- Locks Torque Converter and raises trans-line pressure
- Works with Banks Exhaust Brake

## **Banks TransCommand** (P/N 62570)

- Produces smooth, firm, light-throttle shifts and solid, decisive heavy-load shifts.
- Eliminates excessive clutch slippage

## **Banks Billet Torque Converter** (P/N 72521)

- Higher torque capacity over stock
- Lockup clutch is slip-resistant so transmission fluids stay cooler and transmission life is prolonged.

## **Banks Diesel Tuner Six-Gun** (P/N 66513-66515) **Big Hoss** (P/N 66505)

- Adds power safely to your vehicle
- Engine and transmission safeguards
- Change power levels on-the-fly

## **Thermocouple**

- Add a temperature limiting function to your Diesel Tuner

## **Banks QuickTurbo** (P/N 24456-24457)

- More boost through the powerband
- Does not over-boost
- Turbo-diesel efficiency

## **OttoMind Programmer** (P/N 66064)

- Contains Banks tunes that boost your vehicles HP, Torque and MPG.
- Displays a host of critical engine functions
- Provides "service technician" diagnostic capabilities
- Has upgradeable functionality, so it will never be out of date

**Banks Git-Kit Systems  
(P/N 47401, 47511-47514)**

**Contains:**

- Monster Exhaust
- Big Hoss Module

**Banks Stinger Systems**

**Contains:**

- Ram-Air IntakeFilter
- Monster Exhaust
- Big Hoss Module
- Big Head Wastegate Actuator

**Banks PowerPack Systems**

**Contains:**

- Ram-Air Intake Filter
- Monster Exhaust
- Quick-Turbo
- TransCommand
- Techni-Cooler System
- Big Head Wastegate Actuator

**Banks Six-Gun Bundle  
(P/N 46594-46613)**

**Contains:**

- Ram-Air Intake Filter
- Monster Exhaust
- Six-Gun Tuner
- TransCommand
- Big Head Wastegate Actuator

**Banks Big Hoss Bundle  
(P/N 46623-46643)**

**Contains:**

- Ram-Air Intake Filter
- Monster Exhaust
- Six-Gun Tuner
- TransCommand
- Big Head Wastegate Actuator
- Techni-Cooler System
- Big Hoss Module
- Power Elbow

**Banks Power Combo 1**

**Contains:**

- Big Hoss Module
- TransCommand
- Big Head Wastegate Actuator

**Banks Power Combo 2**

**Contains:**

- Six-Gun Tuner
- TransCommand
- Big Head Wastegate Actuator

**Banks Power Combo 3**

**Contains:**

- Big Hoss Module
- Monster Exhaust

**Banks Power Combo 4**

**Contains:**

- Big Hoss Module
- TransCommand
- Big Head Wastegate Actuator
- Six-Gun Tuner

**For More Information please call (800) 438-7693  
or Visit us online @ [www.bankspower.com](http://www.bankspower.com)**

Dear Customer,

If you have any questions concerning the installation of your Banks Power system, please call our Technical Service Hotline at (888) 839-2700 between 7:00 am and 5:00 pm (PT). If you have any questions relating to shipping or billing, please contact our Customer Service Department at (888) 839-5600.

Thank you.

## General Installation Practices

- 1.** For ease of installation of your Banks system, familiarize yourself with the procedure by reading the entire manual before starting work.
- 2.** The exploded view provides only general guidance. Refer to each step and section diagram in this manual for proper instruction.
- 3.** Throughout this manual, the left side of the vehicle refers to the driver's side, and the right side to the passenger's side.
- 4.** Disconnect the ground cable from the battery (or batteries, if there are two) before beginning work.
- 5.** Route and tie wires and hoses a minimum of 6 inches away from exhaust heat, moving parts and sharp edges. Clearance of 8 inches or more is recommended where possible.
- 6.** When raising the vehicle, support it on properly weight-rated safety stands, ramps or a commercial hoist. Follow the manufacturer's safety precautions. Take care to balance the vehicle to prevent it from slipping or falling. When using ramps, be sure the front wheels are centered squarely on the topsides; put the transmission in park; set the hand brake; and place blocks behind the rear wheels.  
**Caution! Do not use floor jacks to support the vehicle while working under it. Do not raise the vehicle onto concrete blocks, masonry or any other item not intended specifically for this use.**
- 7.** During installation, keep the work area clean. Do not allow anything to be dropped into intake, exhaust, or lubrication system components while performing the installation, as foreign objects will cause immediate turbocharger and/or engine damage upon start-up.

# Installation Instructions

Figure 1A- 1999 with Catalytic Converter

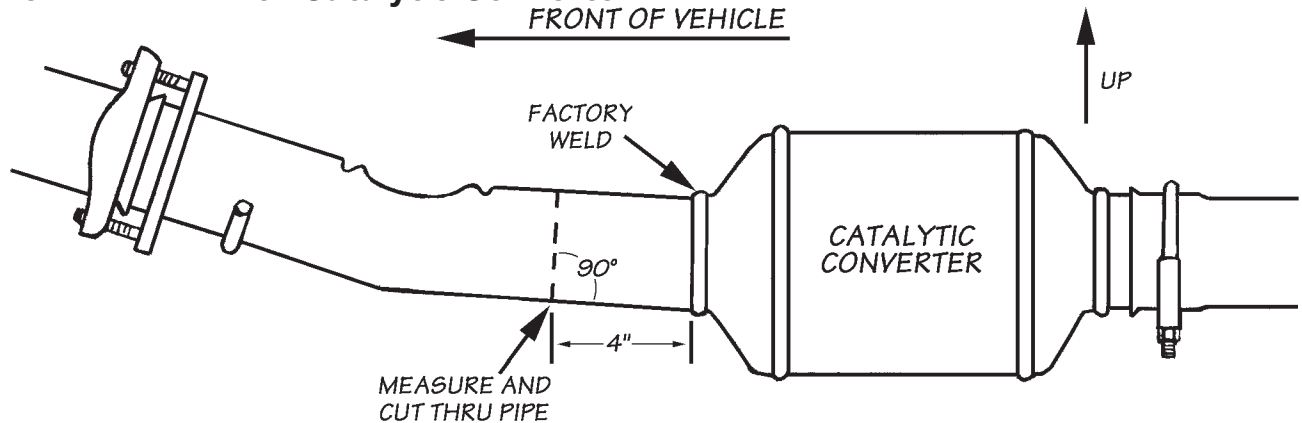
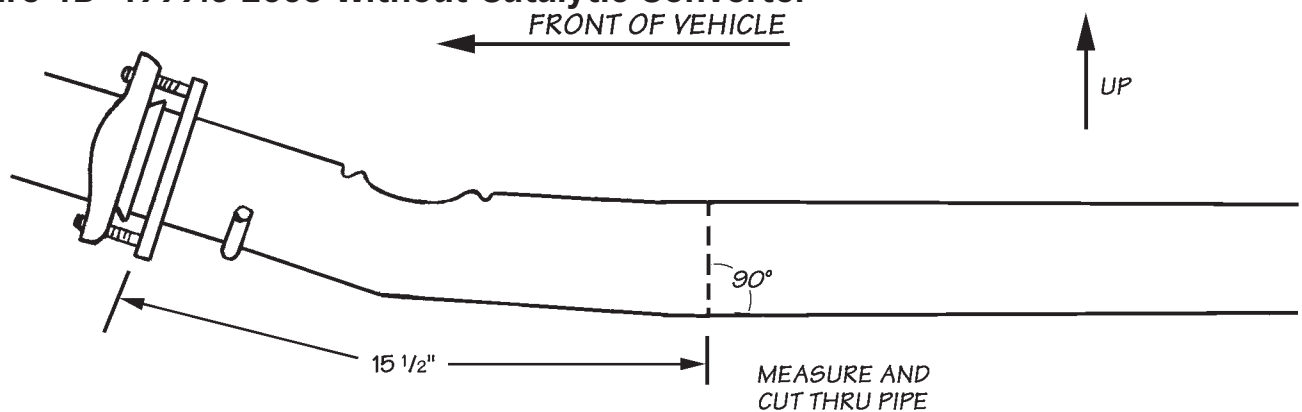

Figure 1B- 1999.5-2003 without Catalytic Converter



## EXHAUST INSTALLATION (Part 1 of 2)

For Git-Kit installation,  
proceed to Step 2.

1. Replace the factory air filter element with the Banks Ram-Air™ filter.
2. Raise the vehicle on a hoist or safety stands to provide access to the exhaust system. Loosen the clamp at the front of the muffler and pry the muffler and tailpipe hanger pins from the rubber hangers. Remove the muffler and tailpipe from the vehicle. Cutting the tailpipe may ease the process of removal.

**WARNING:** At the outlet of each exhaust manifold, locate the short section of tubing that feeds exhaust up to the turbocharger. Check these tubes to ensure that they are not loose, as we have found several new vehicles with problems in this area. Correct this condition now or soon after installation of the PowerPack components to eliminate dangerous exhaust leaks and poor turbocharger performance.

For Git-Kit installation,  
proceed to Step 24.

3. For 1999 vehicles with catalytic converter: Mark a point 4 inches from the forward edge of the weld at the inlet of

the catalytic converter on the downward facing side of the pipe (see Figure 1A). For 1999.5-2003 vehicles without catalytic converter: Mark a point 15 1/2 inches back from the forward side of the 2-bolt flange of the intermediate pipe. Make the mark on the downward facing side of the pipe (see Figure 1B).

4. Loosen the two bolts at the front of the catalytic converter or intermediate pipe and pry the hanger pin on the pipe inlet from the rubber hanger. Remove the pipe assembly from the vehicle. Disconnecting the extension pipe from the outlet of the converter may ease the process of removal.

**IMPORTANT:** If the vehicle is equipped with a catalytic converter, it should be inspected. Diesel catalysts may become plugged with soot and can cause a restriction to exhaust flow, impeding performance. Shine a powerful flashlight into the inlet end of the converter. Observe the light through the other end of the converter. The full circle of the flashlight should be visible without any blockage in the gridwork of the catalyst. If excessive soot is observed, the catalyst may need to be cleaned. **TAKE PRECAUTIONS to avoid blowing soot toward the work area or where it could be inhaled. ALWAYS use breathing protection.** Also inspect the catalyst for damage (i.e. chips, bent corners, etc.) to the gridwork. If your catalytic converter is damaged, it may be covered under your vehicle's emissions warranty.

**5.** Using a reciprocating saw, make a cut in the turbine outlet pipe about an inch downstream of the factory heat shield being careful not to damage the heat shield, as it will be reused. Remove the V-clamp that secures the factory turbine outlet pipe to the turbocharger outlet. Remove both portions of the pipe from under the vehicle.

**CAUTION:** Anytime the turbocharger is removed from the engine, take care that no foreign objects enter any of the turbocharger connections on the engine or the turbocharger. Foreign objects entering air, exhaust, or oil connections may cause major damage to the engine and/or

**Figure 2- Securing Heat Shield**

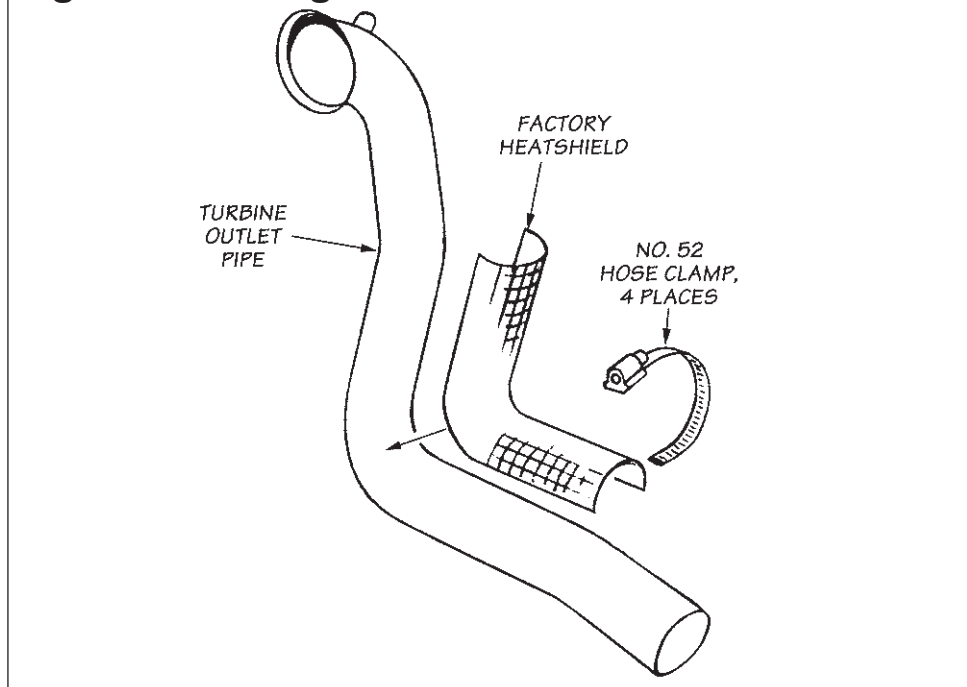

turbocharger and is not covered under any warranty. Cover the open end of the intercooler pipe with a rag, as this pipe is very susceptible to foreign object entry.

**6.** At the mark previously made, cut through the pipe square with the remaining face of the pipe.

**7.** Cut through the metal straps that hold the heat shield onto the factory turbine outlet pipe. Secure the heat shield to the Banks Monster® T.O.P. turbine outlet pipe using the clamps provided (see Figure 2).

**For Stinger installation proceed to Step 21.**

#### TURBOCHARGER REMOVAL

**8.** Remove the decorative plastic cover directly over the engine.

**9.** Loosen the clamp holding the air intake hose at the turbocharger compressor inlet. Pull the hose free of the turbo compressor. Disconnect the

boost line attached to the nipple on the wastegate actuator. Disconnect wiring and plastic tubing attached to components on the turbo compressor discharge plenum casting.

**10.** Loosen the four clamps on the hoses connecting the compressor discharge plenum casting to the intake manifolds. Loosen the clamp attaching the plenum to the turbocharger compressor outlet and the intercooler duct. Remove the compressor discharge plenum from the engine. Cover the two intake manifold hose nipples with clean rags to prevent foreign objects from entering the engine.

**11.** Disengage the exhaust backpressure control actuator rod by sliding the cover on the end of the rod back toward the turbocharger and pulling the rod downward. This rod is below the turbine housing; it is not the wastegate actuator rod

that runs across the top of the turbocharger (see Figure 3).

**12.** At the rear of the turbine housing, loosen and remove the V-band clamp attaching the turbine housing to the exhaust inlet casting. Remove the two bolts attaching the turbocharger bearing housing to the pedestal base mounted on the engine. Remove the turbocharger from the engine by lifting while lightly tapping the turbine housing with a hammer.

**13.** Remove the two O-rings from the junction of the turbocharger bearing housing and pedestal mount. Place a clean rag over the oil passages in the pedestal mount and the exhaust inlet casting to prevent foreign object entry.

**14.** At the back side of the turbocharger, locate the small e-clip that retains the actuator rod end on the wastegate arm.

Using a small screwdriver, carefully pry the clip off of the wastegate arm and retain for reuse.

**CAUTION:** This clip is very small and is easy to lose. It may help to use a magnet to retain the clip as you remove it.

Loosen the two wastegate actuator nuts on the turbocharger compressor housing and remove the actuator.

**15.** Clamp the turbocharger assembly in a vise. Do not use the compressor inlet or outlet to clamp the turbocharger. The compressor housing is aluminum and could be damaged. Observe and mark the relationship of the turbine housing to the center section of the turbo assembly.

**16.** Remove the exhaust backpressure control valve from

the factory turbine housing, and install it onto the new turbine housing with original hardware. Duplicate the orientation of the original assembly. Use anti-seize on the bolts.

**17.** Remove the four bolts securing the turbine housing to the turbocharger center section. If the turbocharger is more than a few months old, it may be necessary to spray some Liquid Wrench (or similar rust penetrating lubricant) into the joint between the turbine housing and the center section. Work the housing loose from the center section by tapping with a hammer and brass drift or a soft face hammer. Work from side to side and use plenty of lubricant until the housing is loose from the center section. Pull the housing straight off of the center section to avoid damaging the turbine blades.

**Figure 3- Disengage Exhaust Back Pressure Control Actuator Rod**

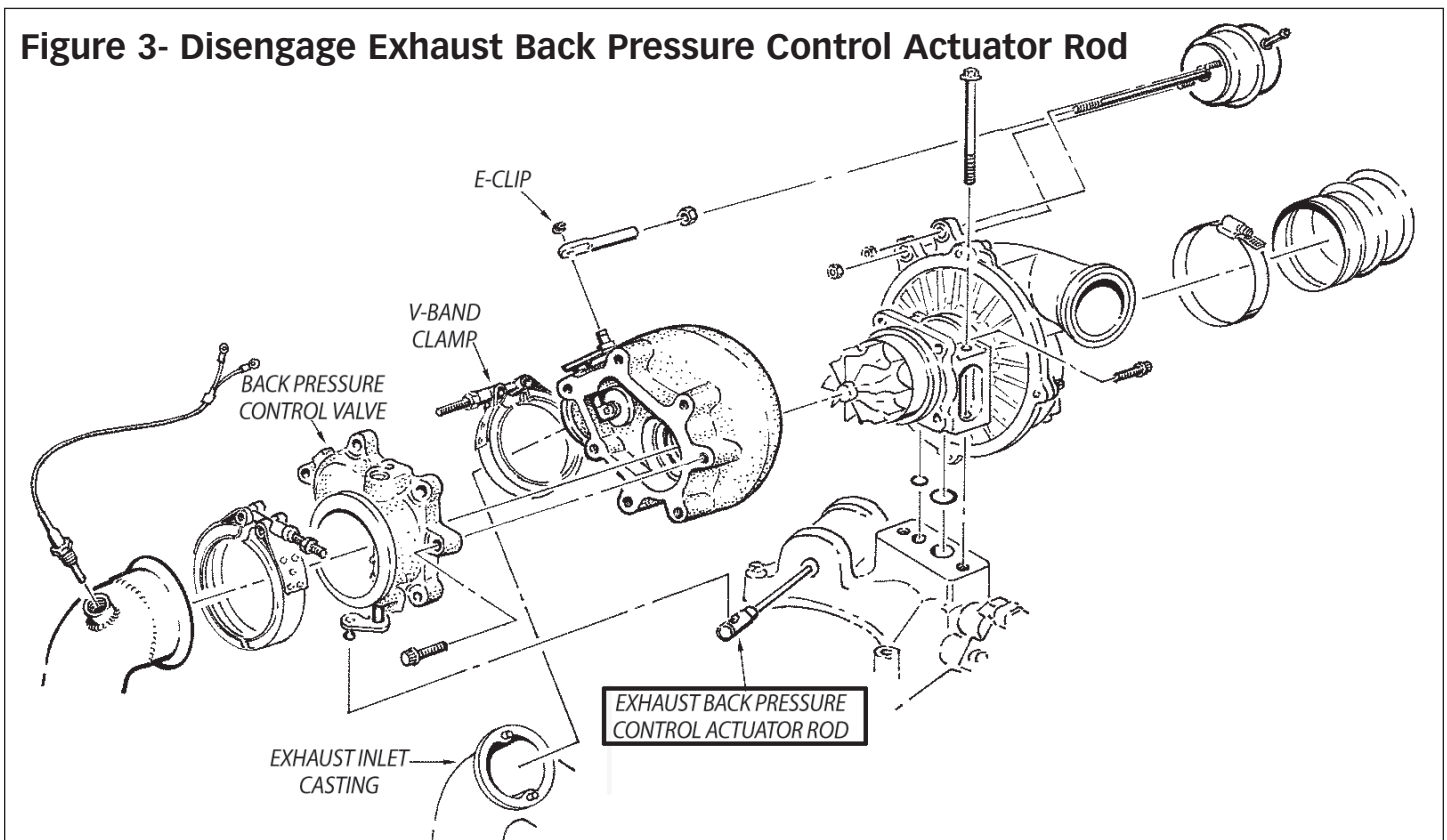

## TURBINE HOUSING AND COMPRESSOR WHEEL INSTALLATION

**18.** For 1999.5-2003 model year: Remove the five bolts around the outside of the compressor cover and carefully remove the cover by pulling it straight off the turbocharger assembly, avoiding contact with the compressor wheel. Use caution to avoid damaging the sealing o-ring around the outside diameter of the compressor back plate.

**19.** Secure the turbine wheel in a vise by clamping the hub of the turbine wheel. Remove the compressor wheel using a  $\frac{5}{8}$ " socket. Install the new compressor wheel provided in the kit. Slide the wheel onto the shaft and lightly turn the wheel to engage the threads. If the wheel does not easily engage the threads, back the wheel off and try again. It may be helpful to listen for a small click while rotating the wheel counterclockwise, and then rotate the wheel clockwise again. Once the wheel has engaged the threads properly, spin it on by hand until snug. Using a torque wrench, tighten the assembly to 100 in/lbs. Reinstall the compressor cover, making sure that the o-ring is properly seated against the backplate of the turbo. Reinstall the five bolts and tighten.

**20.** Place Banks Quick-Turbo® turbine housing onto the center section, again paying careful attention to the turbine blades. Apply some anti-seize to the four bolts and reinstall them. Check the orientation of the assembly, then tighten the bolts.

**21.** Install the Banks Big Head actuator onto the turbocharger. Tighten the lock nuts on the mounting studs and adjust the rod end until the hole aligns with the wastegate arm pin. Turn the rod end link clockwise an additional six full turns, such that it will add preload to the wastegate. Apply a regulated supply of air pressure to the nipple on the actuator until the rod extends enough to slip over the wastegate arm pin. Install the e-clip onto the wastegate arm pin to retain the actuator rod. Tighten the jam nut down on the end link.

### For Stinger installation proceed to Step 24.

**22.** Reinstall the turbocharger onto the pedestal assembly on the engine. Make sure the sealing area on the pedestal assembly and the bottom of the turbocharger are clean, and the new O-rings provided are in place, then bolt the turbocharger to the pedestal. Reinstall the V-band clamp attaching the turbine housing to the exhaust inlet casting.

**23.** Reinstall the air inlet hose to the turbocharger compressor air inlet.

**24.** Loosely clamp the upper portion of the turbine outlet pipe to the exhaust backpressure control valve on the turbocharger. Slide two  $3\frac{1}{2}$ -inch exhaust clamps over the lower portion of the turbine outlet pipe and install the pipe, aligning the hanger pin in the rubber hanger. Reinstall the catalytic converter or intermediate pipe by slipping the inlet into the lower portion of the turbine outlet pipe (see Figure 4).

*NOTE: On some Powerstrokes a ground strap is bolted on back of the cylinder head. This bolt may interfere with the Banks turbine outlet pipe. If so, remove the bolt and relocate it in the cylinder head.*

**25.** Slide a  $3\frac{1}{2}$ -inch exhaust clamp over the inlet of the muffler. Reinstall the extension pipe, if removed, and install the Banks Dynaflow® muffler onto the end of the intermediate pipe, aligning the slot with the raised tab. Insert the hanger pins into the rubber hangers at the front and back of the muffler.

**26.** Slide a  $3\frac{1}{2}$ -inch exhaust clamp over the outlet of the muffler. Install the Banks Monster® tailpipe over the rear axle and into the outlet of the Banks Dynaflow muffler. Insert the hanger pin into the rear rubber hanger.

**27.** Position all the exhaust components such that all the hanger pins are parallel with the ground and all exhaust tubing is located properly. Lightly tighten the clamps to maintain position. The tailpipe tip should be positioned 2 to  $2\frac{1}{2}$  inch below the bottom edge of the fender. All hangers should be level and hanging slightly forward (see Figure 5).

**28.** With everything positioned properly, begin tightening all exhaust clamps, beginning with the V-band clamp at the turbine discharge, and working down stream.

**For Git-Kit Installation, proceed to Step 75.**

**For Stinger Installation, proceed to Step 60.**

**For Stinger-Plus Installation, proceed to Step 51.**

**For PowerPack Installation, continue with Step 29.**

## INTERCOOLER INSTALLATION

**29.** Remove the factory intercooler plumbing from the vehicle. Loosen the clamps on the boost tubes and remove the boost tubes. (It is assumed that the compressor discharge plenum casting has been removed from the vehicle at this point.)

**30.** To remove the factory intercooler, it will be necessary to remove the grille assembly. At the front of the vehicle, remove the pushpins holding the rubber air deflector to the grille support and remove the air deflector. Remove the screws at the top of the grille, dis-connect the lower clips with a small screwdriver, and remove the grille.

**31.** On each side, remove the bulb from the headlight assembly. Remove the two bolts below the turn signal/ marker light combination and remove the assembly by pulling it directly forward. Remove the bulbs from the turn signal/ marker lights or disconnect the connectors to separate it from the vehicle.

**32.** Remove the pushpin and the hood cable clip to disconnect the left air deflector from the radiator core support. Separate the left air deflector from the grille support by removing the pushpins from the bracket on the grille support. Repeat this process for the right side air-deflector, removing the pushpins from the core support and grille support.

**33.** Remove the upper a/c condenser brackets. Remove the grille support bracket attaching bolts and remove the grille support from the vehicle. The a/c condenser needs to be lifted at the same time as the grille support is pulled away from the vehicle. Pull from the bottom at first to pivot the support upwards as you pull forward. The a/c condenser will fit between the air deflector brackets as the support moves forward. Be cautious of the corners of the front fenders as the condenser is lifted up. It may be beneficial to cover the fender corners with masking tape or some other form of protection.

**34.** Scribe a line around the hood latch with a sharp instrument to mark the location of the latch, then remove the latch from the upper radiator support. Do not remove the cable from the latch. Move the latch out of the way.

**35.** Remove the jacking tools from the core support and remove the coolant reservoir bolt from the jacking tool mount bracket. Remove the upper radiator brackets. Remove the upper diagonal brace bolts from the upper radiator core support. Remove the wiring harness from the intercooler mounting studs and remove the studs from the upper radiator support. Remove the six bolts on each end of the upper radiator core support cross bar and remove the upper core support cross bar from the vehicle. It may be necessary to pry the cross bar up out of the slot in the core support.

**36.** Pull the air conditioning condenser up out of the lower

brackets and swing it up over the engine and out of the way. Be careful of the tubes that carry pressurized refrigerant. Do not bend the tubes as they are aluminum, and can be easily damaged. Using a bungee cord or similar equipment, temporarily suspend the condenser from the hood of the vehicle, out of the way.

**37.** Remove the bolt attaching the power steering cooler to the diagonal brace. Remove the diagonal braces from the lower radiator core support. Tilt the intercooler forward and remove it up and out of the vehicle.

*NOTE: Later models do not have diagonal braces, unbolt power steering cooler from brackets as required.*

**38.** Using the four  $\frac{1}{4}$ "-28 x 2" bolts, washers and nylock nuts, loosely bolt the new lower intercooler mounting brackets to the lower mounting crossbar. Position this mounting assembly into the vehicle as shown in Figure 4. Using the lower diagonal brace mounting holes as locations, position the crossbar assembly level in the vehicle and temporarily bolt the brackets to the core support using the lower diagonal brace bolts. Using the brackets as a template, mark the four holes necessary to complete the attaching of the lower mounting brackets, and drill four  $\frac{1}{8}$ " holes in those positions. Attach the lower mounting brackets to these holes in the core support with the four #10 sheet metal screws provided. Now remove the two factory diagonal brace bolts.

# Figure 4

See pages 21-22 for item descriptions

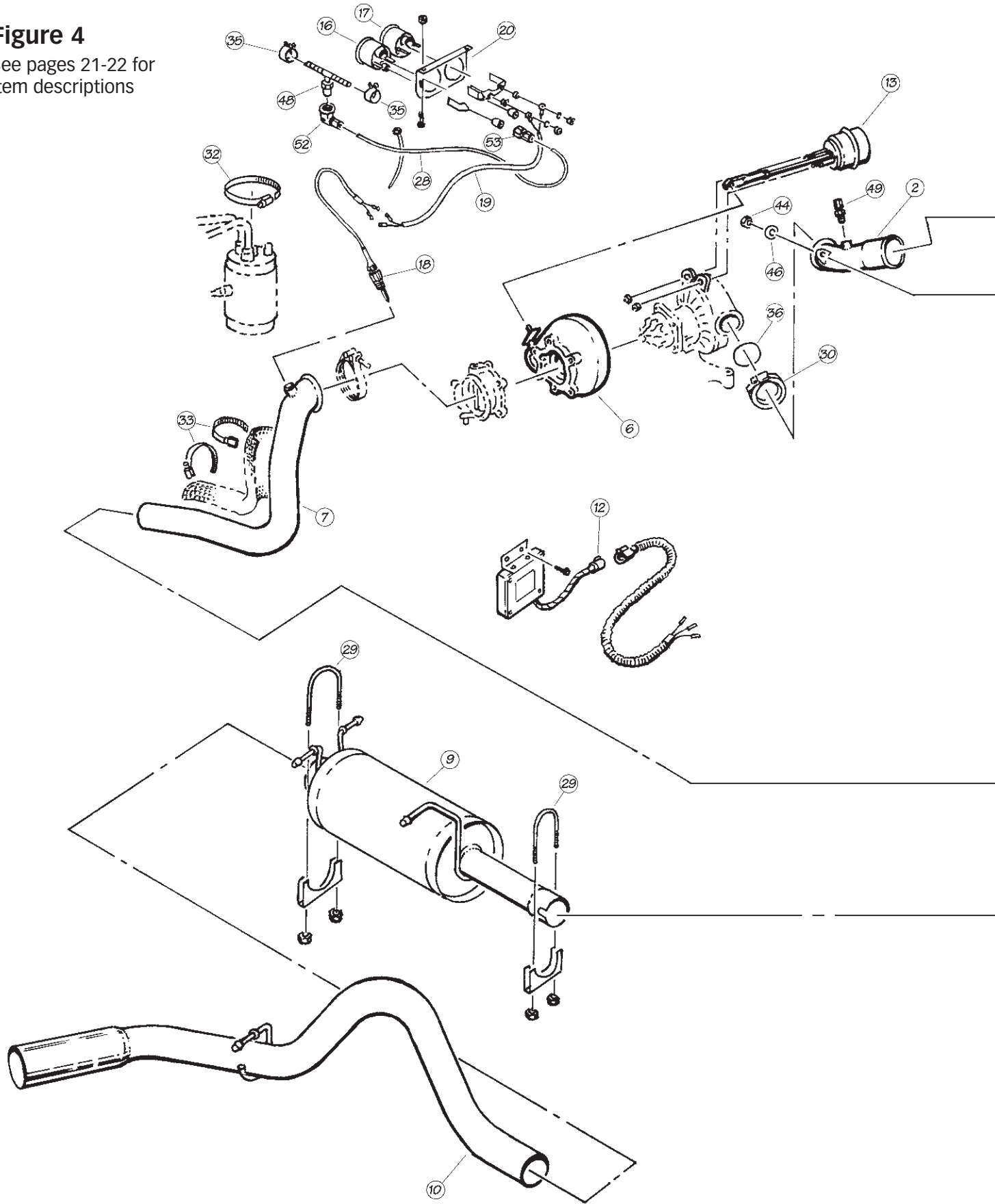

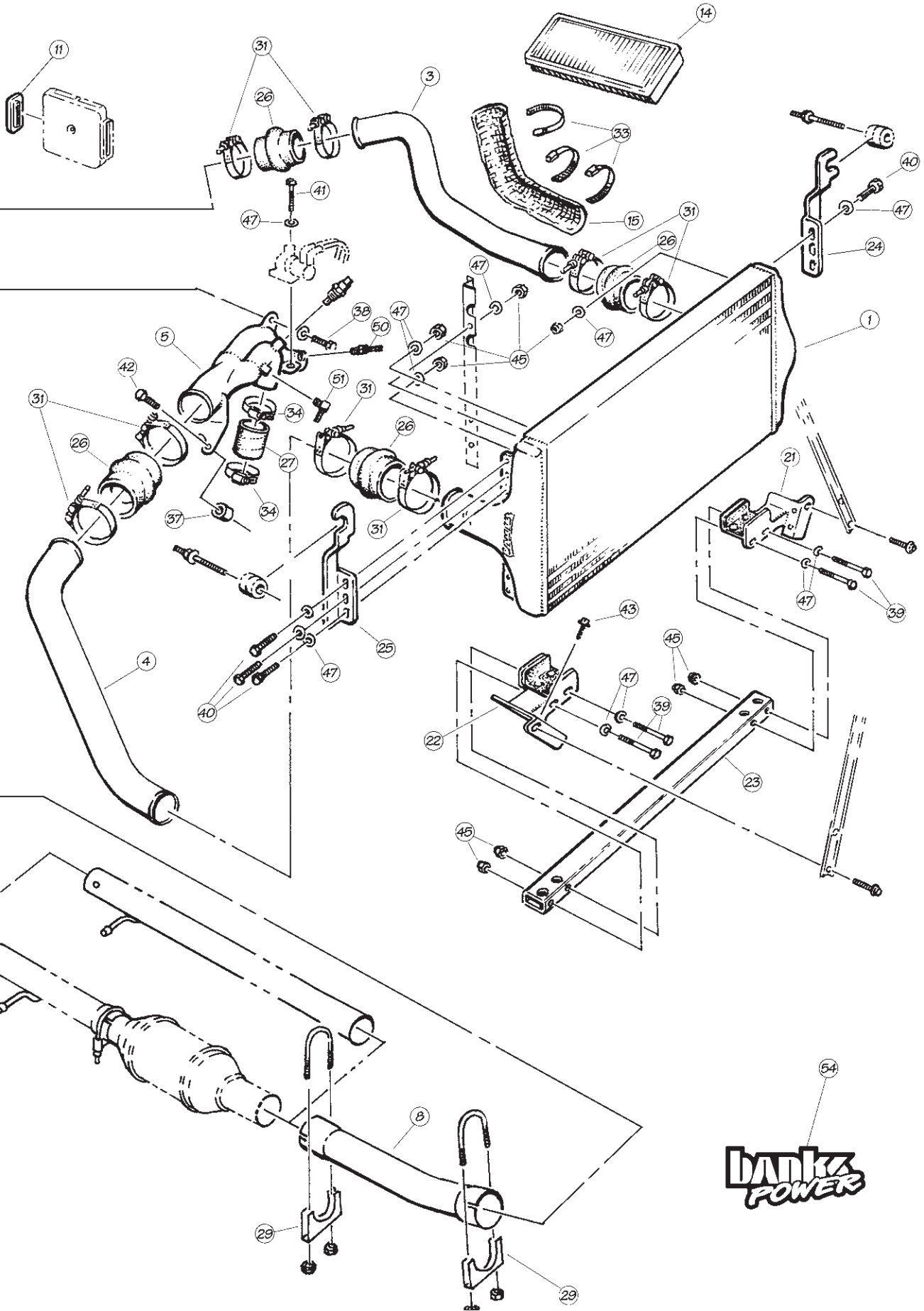

**BANKZ  
POWER**

*NOTE: On later model vehicles without diagonal braces and associated bolt holes, slide the lower intercooler mounting crossbar, with brackets loosely attached, up the sides of the core support opening until the brackets come against the bottom edges for the "ears" that overlap the inside edge of the core support opening. If the lower intercooler mounting brackets cannot be slid out far enough on the crossbar to contact the sides of the core support opening at this elevation, slide each bracket outward on the crossbar as far as it will go, then tighten the 1/4" thru-bolts, set the crossbar assembly in the core support opening, and level it to the vehicle.*

With the crossbar assembly positioned in the core support opening as indicated, scribe the core support through the four holes on the inside edges of the brackets, being certain that the front flanges of the brackets (with the single unused bolt hole) are against the face of the core support. Drill four 1/8" holes at the scribed locations, then attach the brackets to the core support with four #10 sheet metal screws provided.

**39.** Remove the rubber air deflector strips from the ends of the factory intercooler by snipping the plastic ties that run through the intercooler fins. Attach the deflectors to the inboard side of the 3-hole tabs on the Banks intercooler by installing one 1/4-28 x 1" hex bolt, washer, and nylock nut assembly through the bottom hole on the lower tab on each

end of the intercooler and the existing bottom hole on each deflector strip. The remaining three holes on the deflector strips will not line up with the holes in the intercooler. Drill or punch a new set of holes in the deflector strips to line up with the upper holes in the lower tabs on the intercooler, then install a 1/4-28 x 1" hex bolt, washer, and nylock nut assembly in each of these locations. (See Figure 4) Drill or punch a third set of holes through each deflector strip to line up with the middle hole in the upper tabs on the intercooler.

**40.** Loosely bolt the upper brackets to the Banks Techni-Cooler as shown in Figure 4 using four 1/4-28 x 1" hex bolts, 1/4" washers and nylock nuts through the outboard holes in the two upper tabs on the intercooler.

**41.** Trim the rubber air deflector to clear the upper bracket attaching nuts so the deflector will sit flat against the tab on the intercooler. Attach the deflectors to the intercooler at the middle hole in each upper tab using another pair of 1/4"-28 bolt assemblies. Do not tighten these bolts yet.

**42.** On the passenger side of the engine compartment, locate the air conditioning filter/dryer assembly. It will be necessary to modify the clamping bracket to allow clearance for the new tube assembly. Remove the upper filter dryer bracket by unbolting in three places. Using a hacksaw or other cutting tool cut the forward half of the clamp off in front of the elevated tab across from the opening of the clamp.

**Figure 5- Hanger Placement**

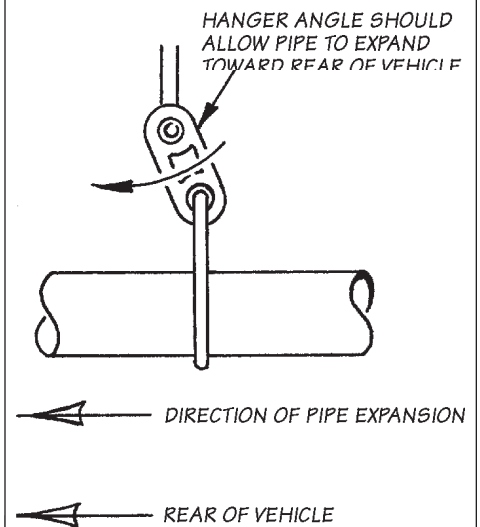

Next cut the remaining tab off of the open side of the clamp. Reinstall the bracket using a #56 hose clamp provided to secure the filter/dryer unit to the bracket.

**43.** Slide three #52 hose clamps over the left boost tube. These will be used later to secure the heatshield in place. Set both boost tubes into place in the vehicle. Place two of the 3" silicone hump hoses onto the intercooler inlet and outlet, and fasten with the T-bolt clamps provided. Position two more clamps on the open ends of the silicone hoses, and place the intercooler into the vehicle slipping the boost tubes into the hoses on the intercooler and the intercooler into the rubber saddles on the lower mounting brackets. Do not tighten these clamps yet.

**44.** Place the air conditioning condenser back into its original position. Reinstall upper crossbar into truck, using the original bolts. Reinstall the diagonal braces to the radiator support and reattach the power steering cooler to the right side diagonal.

*Note: Rotate the upper power steering fluid tube in the clip to allow the hose portion to clear the bottom of the right lower intercooler bracket.*

**45.** Remove the factory rubber isolators from the factory intercooler and install them into the upper brackets of the Banks intercooler. Install the original studs through the isolators into the upper crossbar and tighten them. Tighten the upper mounting bracket bolts on the intercooler.

**For Late 1999<sup>1</sup>/<sub>2</sub>–2001 models proceed to Step 51.**

**46.** Remove the sensors from the factory compressor discharge plenum casting and install them into the Banks TwinRam intake assembly. Remove the heating element from the factory compressor discharge plenum casting and install it in the Banks Twin Ram intake assembly.

**47.** Slide the two 2" silicone hoses up the legs of the TwinRam. Slip two #36 hose clamps over each hose and install the TwinRam to the engine, sliding the hoses down the legs and onto the intake stubs, making sure that the hoses are positioned equally between the TwinRam legs and the manifold stubs. Tighten the clamps. Attach the bracket to the rocker cover using the 8mm x 30mm metric bolts and spacers provided.

**48.** Attach the wastegate control solenoid to the tab on the TwinRam with the supplied  $\frac{1}{4}$ -20 x  $1\frac{1}{4}$ " hex bolt and washer. Reconnect the wiring harnesses to the sensors.

**49.** Attach the right side boost tube to the TwinRam using a 3" silicone hump hose, and two T-bolt clamps.

**50.** Place the new O-ring into the recess in the compressor housing and attach the compressor discharge elbow to the compressor housing with the new v-band clamp provided. A small amount of bearing grease may be used to hold the o-ring in position while installing the elbow. Bolt the compressor discharge elbow to the TwinRam through the tab provided for this purpose using the  $\frac{5}{16}$ " bolt, washers, and nylock nut provided. Install a  $\frac{1}{8}$ -inch NPT x  $\frac{1}{8}$ -inch compression fitting (supplied in the boost gauge kit) in the bung on the compressor discharge elbow. Sparingly apply pipe sealant tape or paste on the male pipe threads, and tighten the hex on the fitting body (NOT the compression nut).

**Steps 51-54 For Late 1999<sup>1</sup>/<sub>2</sub>–2001 models Only**

**All other models Proceed to Step 55.**

**51.** Place the O-ring into the recess in the turbo compressor outlet and reinstall the factory compressor discharge plenum casting on the turbocharger. A small amount of bearing grease may be used to hold the O-ring in position while installing the casting. Slide the hump hoses on the boost tubes onto the compressor plenum discharge casting. Reconnect any wiring or sensor tubes to components on the compressor discharge casting. Reconnect boost line to wastegate actuator.

**52.** To reconnect the exhaust backpressure control valve, hold the cover on the end of the rod back and have someone start the engine. When the rod extends after a few seconds, push it up onto the valve linkage and allow the cover to snap back into position.

**53.** Make sure that the ignition is off, then disconnect all three connectors from the PCM for easier accessibility to the wires.

**54.** While engine is running, check for oil leaks around the base of the turbocharger center section or the pedestal mount. Repair any leaks before continuing.

*NOTE: The most likely cause of an oil leak in this installation is a pinched O-ring at the base of the turbocharger.*

**For Stinger-Plus installation proceed to Step 60.**

**55.** Reposition the left and right air deflectors back into their original positions, and use the pushpins to attach them to the radiator support. Reattach the wiring harness removed from the intercooler mounting studs. Reinstall the original radiator mount brackets onto the radiator upper support. Tighten the bolts. Reattach the radiator overflow tank to the upper radiator bracket. Reinstall the jacking tools to the core support. Reinstall the grille support to the vehicle using the original hardware. Reinstall the air conditioning condenser upper brackets. Reattach the right and left air deflectors to the grille support with the original hardware. Reinstall the hood latch in its original position.

**56.** Reinstall the light bulbs into the turn signal/marker light combinations, and reinstall the combinations into the vehicle. Press them firmly, straight back into the attaching clips and bolt them into place. Reinstall the headlight bulbs into the headlight assemblies. Be careful not to touch the headlight bulbs themselves with your fingers, as oil from your skin can cause damage to the bulbs. If necessary, clean the bulbs thoroughly with rubbing alcohol before reinstalling them.

**57.** Turn on the headlights and turn signals briefly to check for proper operation.

**58.** Reattach the upper radiator air deflector to the grille support and upper radiator support with the plastic pushpins previously removed. Reinstall the grille by pushing it into the lower clips. Reinstall the original screws.

**59.** Recheck all clamps to ensure that they are tight before driving the vehicle.

**60.** If gauges are being installed into an existing gauge panel, this step may be skipped. If gauges and a gauge panel or console are being installed, choose a location where the driver can easily view the gauges. This will typically be to the right of the accelerator pedal, under the lower edge of the dash panel. Mount the gauge panel with the machine screws, washers, and nuts provided.

**61.** Install the DynaFact® pyrometer probe (supplied in the pyrometer kit) in the 1/4-inch NPT bung located at the top of the turbine outlet pipe. Use anti-seize compound on the threads.

Connect the lead-wire to the sensor with the supplied screws. The wires are different lengths to prevent cross connecting. Make sure that the screws are tight. Slip the heat shrink tubing provided over the wire ends.

**62.** Supply moderate heat to the heat shrink tubing to seal the connections. A heat-gun or lighter works well.

**63.** When passing through the firewall either make a hole in a factory grommet or drill a hole and use a new grommet. If a hole needs to be drilled, drill a 5/16-inch hole and deburr it on both sides, so that the wiring or tubing does not get cut as it passes through the hole. For added protection, wrap the wiring with several layers of electrical tape in the area where it passes through the hole. When drilling, check the backside to make sure that there are no components blocking the backside of the hole that would be damaged by drilling.

**64.** Route the pyrometer lead-wire up and across the top of the firewall then down and through the hole in the firewall. Inside the vehicle, route the wire to the gauge location. If routing the lead-wire under the carpet, avoid placing it where the driver's feet will rest on the wire. Tie the wire to existing wire looms and hoses with the cable ties provided.

**65.** Reposition the left and right air deflectors back into their original positions, and use the pushpins to attach them to the radiator support. Reattach the wiring harness removed from the intercooler mounting

studs. Reinstall the original radiator mount brackets onto the radiator upper support. Tighten the bolts. Reattach the radiator overflow tank to the upper radiator bracket. Reinstall the jacking tools to the core support. Reinstall the grille support to the vehicle using the original hardware. Reinstall the air conditioning condenser upper brackets. Reattach the right and left air deflectors to the grille support with the original hardware. Reinstall the hood latch in its original position.

**66.** Pull any excess wire through the firewall, coil it and secure it up under the dash, out of the way. Do not shorten the lead-wire. Note: If it is necessary to replace one of the terminal ends, use a crimp tool only. Do not solder to the wires.

**67.** Locate the rubber hose connecting the intake manifold on the passenger side to the pressure sensor mounted on the firewall. Cut through this hose at a point 3 inches below the sensor. Install the 1/8-inch hose by 1/8-inch NPT tee fitting and the spring band clamps, provided, between the cut ends of the hose as shown in Figure 6.

**68.** Install one 1/8-inch NPT female by 1/8-inch compression 90-degree fitting onto the threaded end of the tee. Sparingly apply pipe sealant tape or paste on the male pipe threads, and adjust the 90-degree fitting to point back toward the firewall, as shown in Figure 6. Do not allow any sealant to cover the small hole in the fitting. Do not over-tighten the plastic fitting.

**69.** Install one end of the 1/8-inch diameter plastic tube provided into the compression fitting on the plastic tee or the fitting on the compressor discharge elbow (PowerPacks only) and tighten the nut. Be sure the plastic tube cannot be pulled out of the ferrule, but do not over-tighten the nut.

**70.** Route the free end of the tube up and along the top of the firewall toward the brake master cylinder assembly. Use caution to avoid kinks in the line. Tie the tube to existing wires and hoses with the cable ties provided. Follow the routing of the pyrometer lead-wire through the firewall.

**71.** Route the plastic tube to the gauge panel and cut the tube to the proper length. Install the gauge through the panel or console using the U-clamp and two hex nuts provided with the gauge.

**72.** Install the 90-degree elbow fitting onto the connection at the back of the gauge. Use Teflon thread sealer on the male threads of the gauge nipple. Do not allow any sealant to cover the pin-sized hole in the end of the gauge nipple.

**73.** Insert the tube into the nut and ferrule on the adapter fitting at the gauge, then tighten the nut against the tube and ferrule. Do not over-tighten.

**74.** Connect the 4-pin connector of each gauge into the back of its corresponding gauge.

**a.** Crimp the remaining Black and RED wires from each 4-pin connector gauge harness to the

butt connectors as shown in **Figure 7**.

**b.** Strip one end of the RED wire and crimp it to the butt connector containing the RED wires from step 'a'.

**c.** Strip one end of the BLACK wire and crimp it to the butt connector containing the BLACK wires from step 'a'.

**d.** Route the RED wire to the fuse box. Locate the appropriate fuse for instrument lighting in the owner's manual. Cut the RED wire as required and strip the end. Crimp the push on connector to the RED wire and connect to the fuse as shown in **Figure 7**. Alternatively, locate power wire to dimmer switch and install T-tap. Cut the RED wire as required and strip the end. Crimp the push on T-tap connector to the RED wire and connect to T-tap on dimmer power wire.

**e.** Locate a metal surface that will serve as an acceptable chassis ground. Cut the BLACK wire to a sufficient length that will allow it to reach the chassis ground and strip the end. Crimp the ring terminal to the BLACK wire as shown in **Figure 7**.

**f.** Drill a 1/8" hole, if required, to attach the ring terminal to the chassis ground. **Caution: If drilling, check the backside to make sure there are no components that may be damaged by drilling.**

**g.** Use the supplied self-tapping screw to secure the ring terminal to the chassis ground.

*NOTE: On vehicles with an automatic transmission, complete the TransCommand installation before proceeding.*

**75.** Be certain battery ground cables have been disconnected.

**Figure 6- 90 Degree Adapter Positioning**

MANIFOLD PRESSURE SENSOR

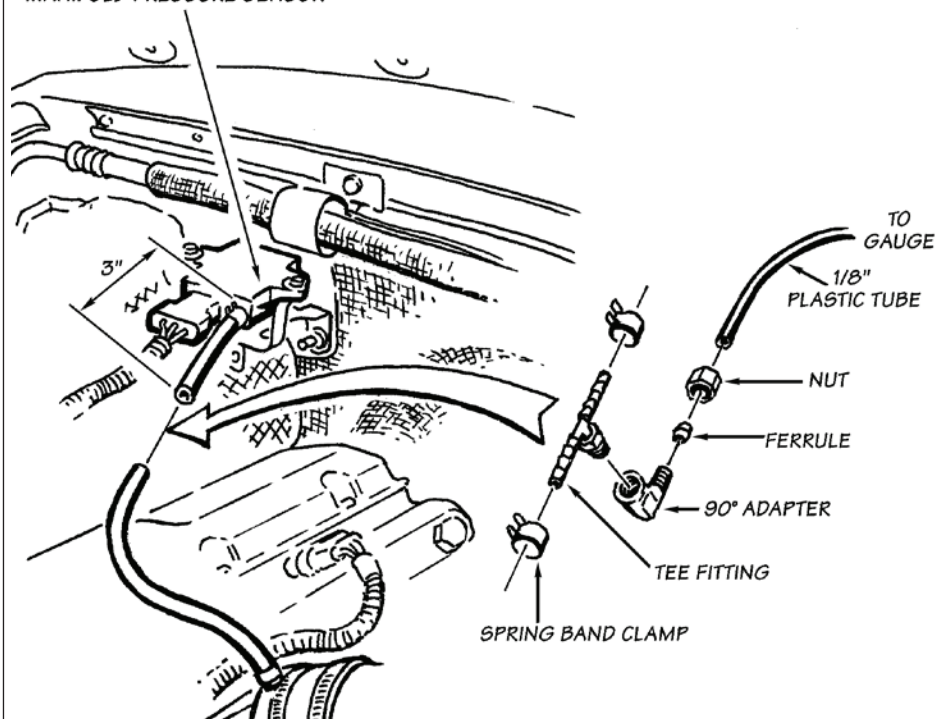
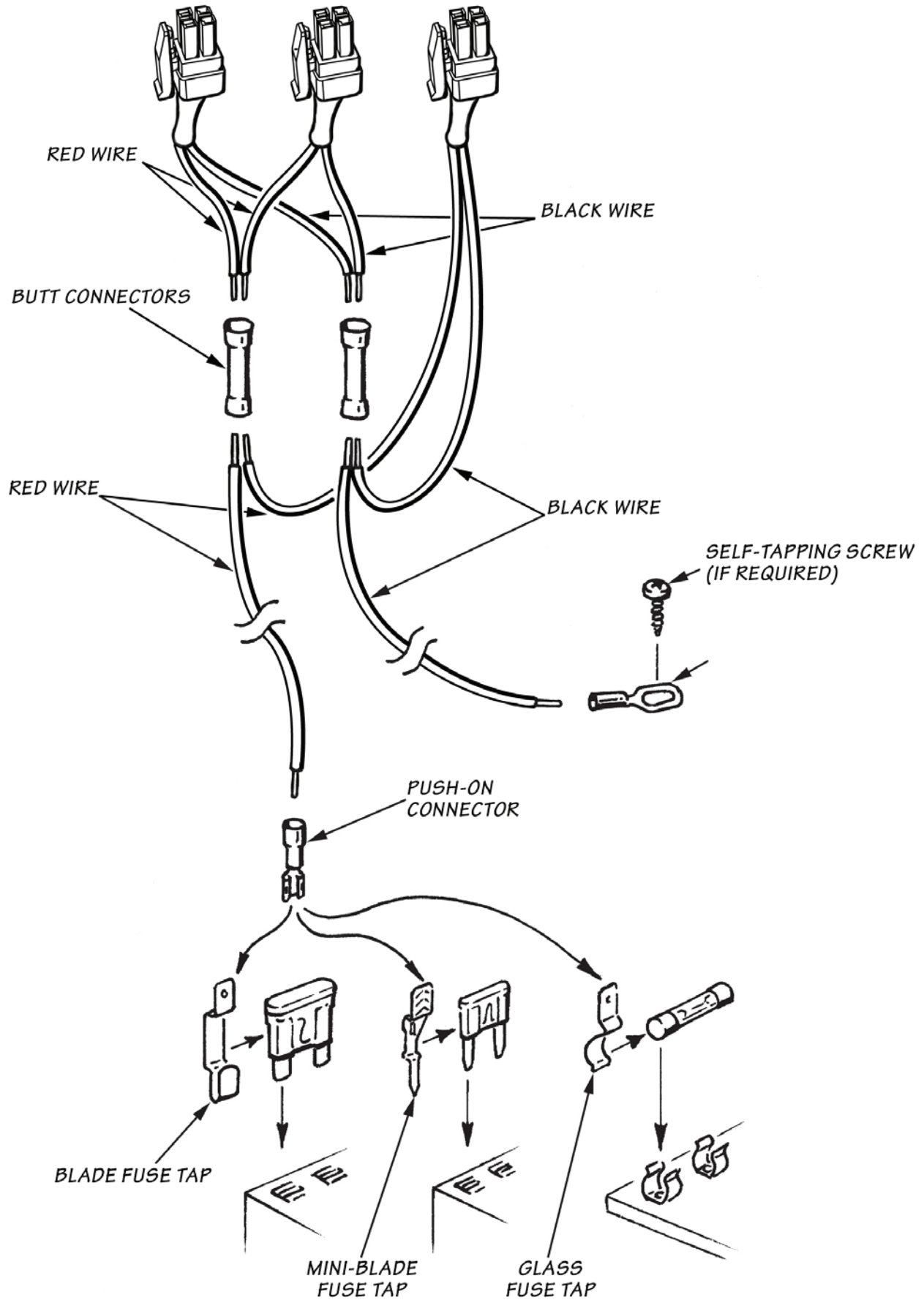

Figure 7

4-PIN CONNECTORS TO GAUGE LED



**76.** Locate the engine control unit (ECU) under the dash toward the left-hand side of the vehicle. It will be housed in a black plastic box bolted to the side of the vehicle. Loosen the bolt attaching the electrical connector to the ECU on the engine compartment side. This will be the connector closest to the left front fender. See Figure 8.

**77.** Loosen the two 7mm hex bolts on the rear portion of the black plastic box. Remove the box and ECU from the vehicle together. Pull the ECU out of the plastic box.

**78.** Note the code printed on the plastic cap on the back of the ECU. This code should compare to the code printed on the Banks OttoMind® box label. Pry the plastic cap from the rear of the ECU using a small screwdriver, exposing

the printed circuit board edge connector inside. Retain the plastic cap. The connector will be coated with grease and a clear silicone type coating, which must be completely removed before installing the Banks OttoMind engine calibration module.

**79.** Using a 5.5mm nut driver, loosen and remove the six bolts that hold the case of the ECU together. Open the case of the ECU, being careful not to lose the plastic spacer or damage any circuitry inside the ECU.

**80.** Clean BOTH sides of the connector. First, clean the white grease off with a tissue. Next, scrape the clear silicone type coating from the connector fingers with the abrasive square provided. It is very important to clean both sides of the board in order to have a good connection between the ECU and the Banks

OttoMind module. It is only necessary to clean the connector fingers. Be careful not to damage any circuit traces on the board further inside the ECU.

**81.** Orient the module so that its edges line up with the edges of the ECU case. If the edges do not line up, the module is rotated 180 degrees off. Place the OttoMind module over the connector, and press firmly to set the connection. DO NOT FORCE the OttoMind onto the connector, as damage may result to either the ECU or the module. If the module does not install with firm pressure, check the orientation and try again.

**82.** Using a band saw or hacksaw cut a portion of the black plastic case away allowing the OttoMind to reside in its proper location. See Figure 9. Reinstall the ECU with the black plastic box, making sure the ground tab is still in place at the lower mounting point. Reattach the wiring harness to the ECU and tighten the retaining bolt. Be careful that all the pins are aligned correctly, as it is possible to bend the pins of the ECU and do permanent damage! Reconnect the batteries.

**Figure 8- Remove ECU and Box from Vehicle**

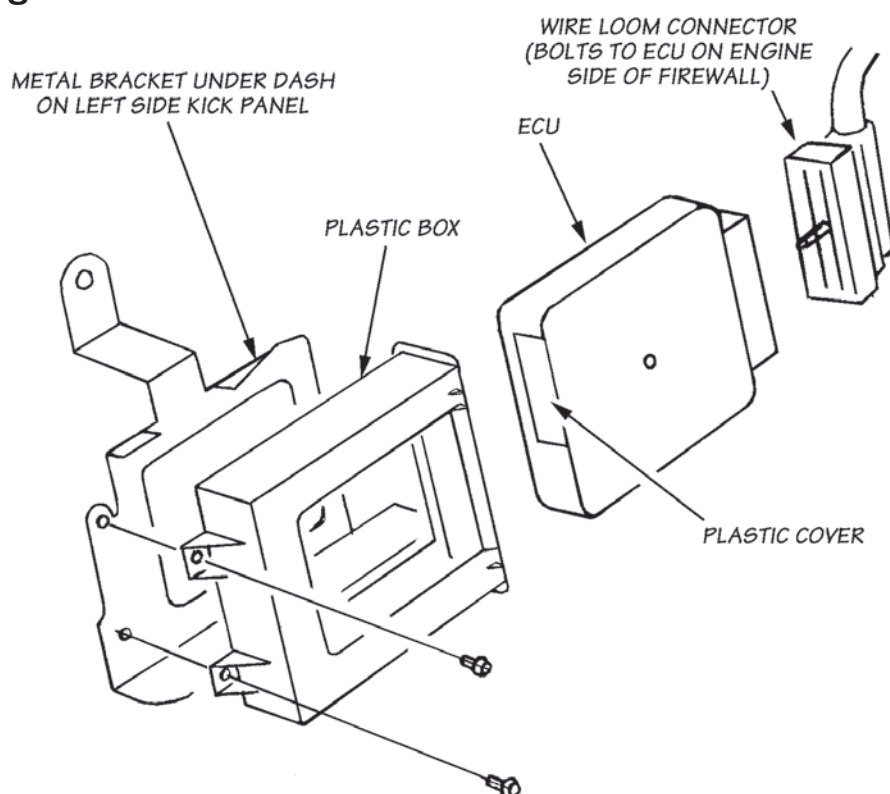

For Git-Kit installation, proceed to Step 84.

**83.** Find, supplied in the kit, the black wire with a ring terminal on one side and a male "fast-on" blade terminal on the other. Install the red "t-tap" connector on the center wire of the MAP sensor as far from the sensor as possible. Pull the wire out of the convoluted plastic tube near the top of the firewall and squeeze the t-tap onto the wire with pliers. See Figure 10. Attach one end of the black wire to the t-tap and the ring terminal end to the ground strap on the firewall.

**84.** Check the operation of the OttoMind and ECU. The vehicle may not start if the coating on the ECU connector is not completely removed or if there is a mismatch of codes. A quick indication of module connections that are not cleaned properly is that the "Wait to Start" indicator will fail to light and the "Check Engine" warning indicator will stay lit after the key is switched on. If the engine fails to start, re-clean the ECU connector, reinstall the module and try again. If the problem persists, contact customer service at Gale Banks Engineering to confirm that the ECU and OttoMind codes match.

**85.** Start the engine and allow it to warm up. Drive the vehicle, listening for any exhaust leaks or rattles. Adjust and tighten clamps or reposition the piping if required. When positioning of piping is finalized, it is a good practice to place tack welds at any slip joints in the exhaust system to prevent slippage.

*NOTE: The exhaust may smoke slightly after initial startup. This is normal and will go away shortly as the grease used in the bending process burns off the inside of the piping.*

**86.** Observe operation of the boost and pyrometer gauges while driving under varying

**Figure 9- Proper Box Cutting Illustration**

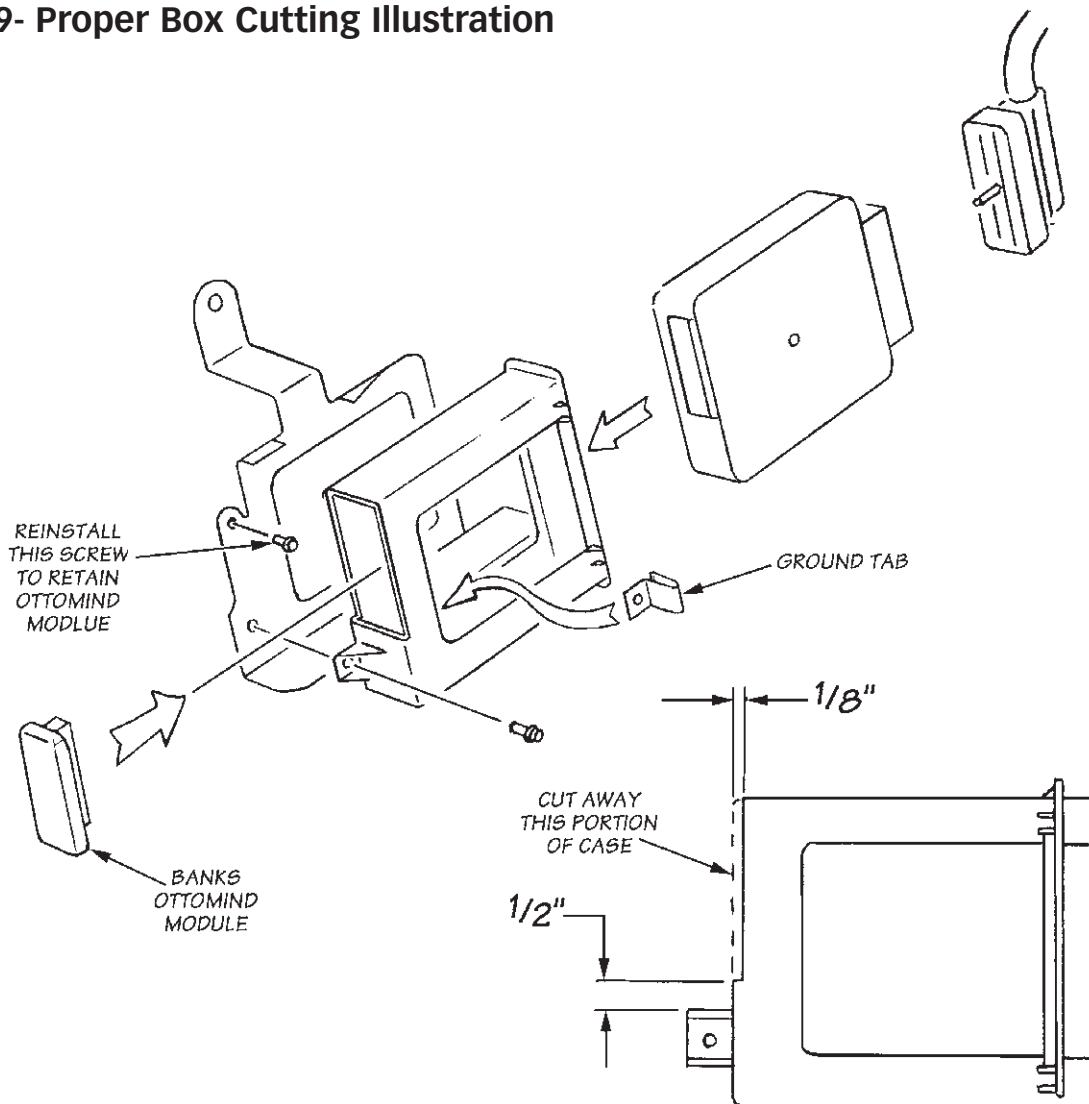

**Figure 10- T-Tap Attachment**

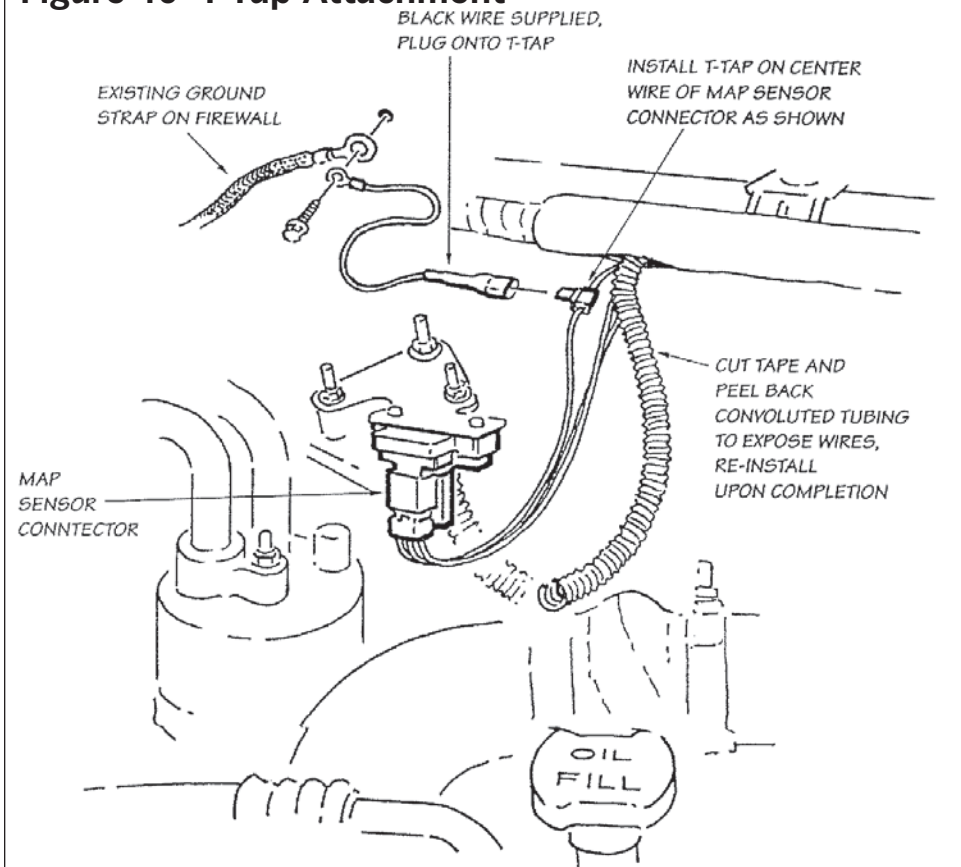

conditions. Turbocharger boost pressure fluctuates as a function of load and rpm. The engine produces lower boost while cruising at light throttle. Maximum boost occurs while climbing hills and heavily loaded during acceleration. Note the boost level during hard acceleration with a given load. If future performance declines, the maximum boost pressure figures may be compared to see if boost has decreased. Lower boost can be caused by turbo ducting leaks, a malfunctioning fuel injection system, or a dirty air filter. Maximum boost pressure settings for the Power Stroke turbo diesel vary considerably, due to manual or automatic trans-mission options, vehicle year and model, and altitude. Boost readings may vary between 18 and 21 psi.

*NOTE: Vehicle performance may be erratic and improper if the module connections are not properly cleaned.*

**87.** Use your pyrometer gauge to monitor exhaust gas temperature (EGT) in the engine. At idle, EGT will be very low, perhaps only 300°F. As the engine accelerates and is under load, the EGT rises. The safe maximum for the EGT is 1050°F. The highest EGT occurs under maximum load at full throttle, such as climbing a steep grade with a heavily laden vehicle. If the vehicle reaches maximum EGT during these conditions, downshift to reduce load, or back off the throttle. We recommend that engine oil temp not exceed 250°F. Optimum oil temperature is around 230°F.

*NOTE: An optional oil temperature gauge is available from Gale Banks Engineering.*

**1.** If the need should arise for you to have your vehicle serviced, the Banks OttoMind should be removed from the engine control unit (ECU). It is common for the service provider to connect a computer diagnostic link to the vehicle regardless of the type of service being performed. When the OttoMind is installed, the computer will return a code that indicates a memory fault with the vehicle ECU. The suggested repair for a fault of this type is replacement of the ECU.

**2.** The operation of the OttoMind is such that the computer is directed to reference certain information in the OttoMind rather than the ECU. Therefore, the memory fault that occurs is not an ECU failure, but rather the presence of an electronic device that the diagnostic computer cannot identify.

**3.** To avoid confusion about whether or not an ECU is properly functioning, simply remove the OttoMind from the ECU before having the vehicle serviced, and reinsert the plastic cap in the ECU access port. The OttoMind can be easily accessed from inside the truck, and it is unnecessary to remove the computer from the vehicle. The OttoMind may be reinstalled after the service is complete.

**4.** It is also not uncommon for a service provider to update the program in the vehicle ECU. If this occurs, it is possible that the programming in the OttoMind will no longer match the ECU

program. If you experience any difficulty with the operation of the Banks OttoMind after service, check with the service provider to determine if an update was performed. Then contact customer service at Gale Banks Engineering for an updated OttoMind, if necessary.

Your system includes two Banks Power logos that have been designed to compliment the Ford badging on your truck. We have provided measurements, which will allow you to place these logos in a position that gives a clean factory look. See Figure 11.

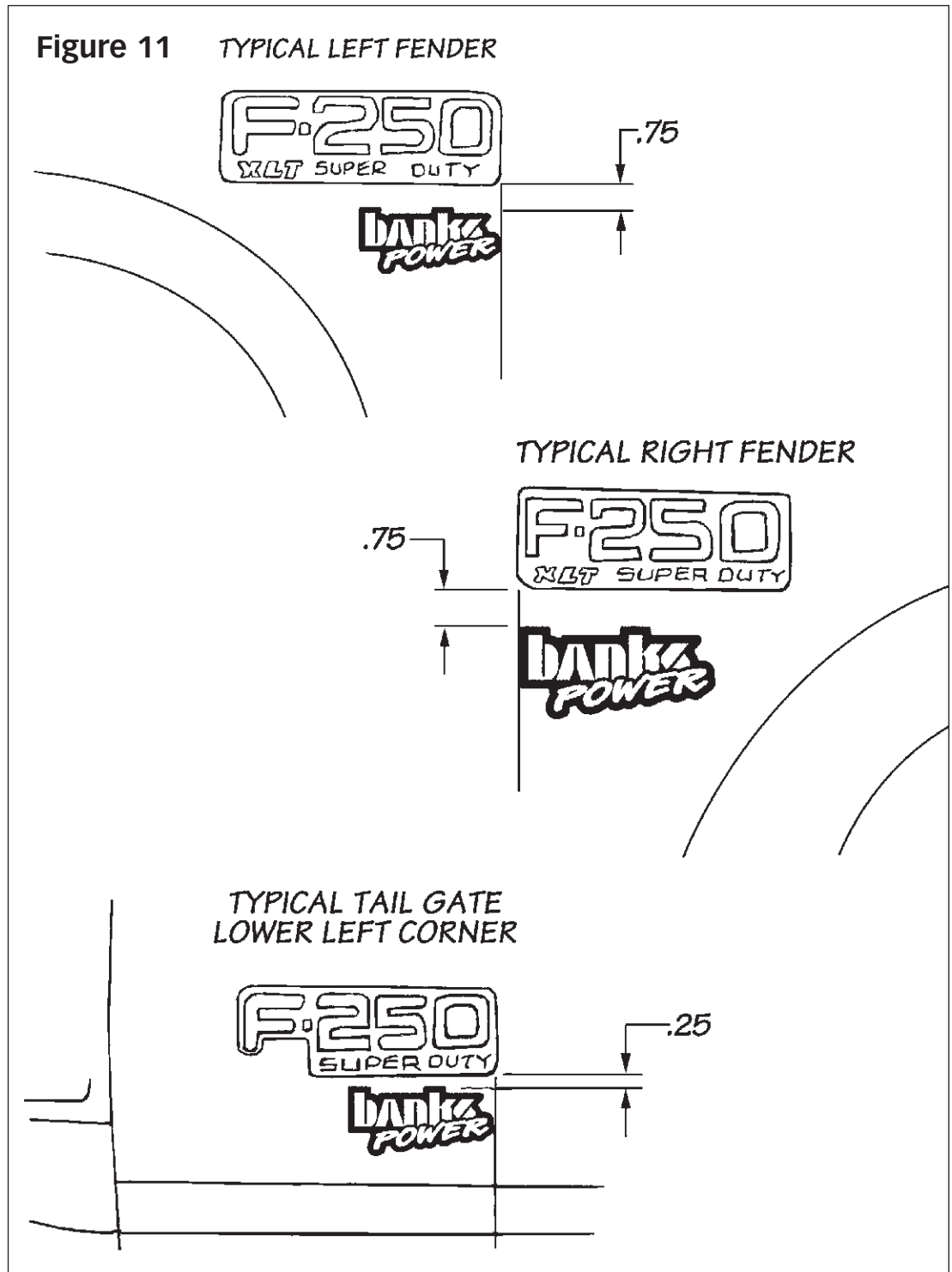

## PARTS LIST, 1999-2003 Ford Power Stroke 7.3L Turbo Diesel

Item #	Part #	Description	Git-Kit	Stinger	Stinger Plus	Power Pack
1	25505	TECHNI-COOLER INTERCOOLER	--	--	--	1
2	41301	ELBOW, Compressor Outlet (99 model only)	--	--	--	1
3	41305	TUBE, Intercooler Inlet	--	--	--	1
4	41309	TUBE, Intercooler Outlet	--	--	--	1
5	41314	TWINRAM, Intake Assembly, (1999 model only)	--	--	--	1
	24440	WHEEL, Compressor, (1999.5-2003 models only)	--	--	--	1
6	24455-01	HOUSING, Turbine	--	--	1	1
7	52152	PIPE, Turbine Outlet, Upper	--	1	1	1
8	*	PIPE, Turbine Outlet, Lower	--	1	1	1
9	52432	ASSEMBLY, Dynaflow Muffler	1	1	1	1
10	53448	PIPE, Monster Tailpipe (53448 99-03 f450/550)	1	1	1	1
	53449	PIPE, Tailpipe Extension	1	1	1	1
11	**	OTTOMIND	1	1	1	1
12	62557	TRANSCOMMAND (automatic only) 4r100	--	1	1	1
13	24338	ACTUATOR, Banks Big Head	--	1	1	1
14	41510	FILTER, Banks Ram-Air	--	1	1	1
15	26002	HEATSHIELD, Blanket	--	--	--	1
	90094	KIT, Service, Banks Ram-Air Filter	--	1	1	1
16	63436	GAUGE, Dynafact Boost	--	1	1	1
17	63432	GAUGE, Dynafact Pyrometer	--	1	1	1
18	--	THERMOCOUPLE, Pyrometer	--	1	1	1
19	--	LEADWIRE, Pyrometer	--	1	1	1
20	63002	PANEL, Mounting, Two-gauge	--	1	1	1
21	25518	BRACKET, Lower Left	--	--	--	1
22	25518	BRACKET, Lower Right	--	--	--	1
23	25524	BAR, Intercooler Mounting	--	--	--	1
24	25521	BRACKET, Upper Left	--	--	--	1
25	25522	BRACKET, Upper Right	--	--	--	1
26	94510	(4) HOSE, Hump	--	--	--	4
27	94251	(2) HOSE, Silicon 2" x 2"	--	--	--	2
28	94445	HOSE, 1/8" Bulk X 11.5'	--	1	1	1
29	52468	(4) CLAMP, Exhaust, 3 1/2"	--	4	4	4
29	52468	(2) CLAMP, Exhaust, 3 1/2"	2	--	--	--
30	92881	CLAMP, V-band	--	1	1	1
31	92871	(8) CLAMP, T-bolt Hose	--	--	--	8
32	92857	CLAMP, Hose, #56	--	--	--	1
33	92853	(7) CLAMP, Hose, #52	--	--	--	7
33	92853	(4) CLAMP, Hose, #52	--	4	4	--
34	92837	(4) CLAMP, Hose, #36	--	--	--	4
35	92877	(2) CLAMP, Spring Band	--	2	2	2
36	93605	O-RING, Compressor Outlet	--	--	--	1
37	41360	(2) SPACER, 5/8"	--	--	--	2
38	91253	BOLT, 5/16"-24 x 1" Hex	--	--	--	1
39	91144	(4) BOLT, 1/4"-28 x 2" Hex	--	--	--	4
40	91140	(10) BOLT, 1/4"-28 x 1" Hex	--	--	--	10

# PARTS LIST, 1999-2003 Ford Power Stroke 7.3L Turbo Diesel

Item #	Part #	Description	Git-Kit	Stinger	Stinger Plus	Power Pack
41	91119	BOLT, 1/4"-20 x 1 1/4" Hex	--	--	--	1
42	91789	(2) BOLT, 8mm 1.25 x 30mm Hex	--	--	--	2
43	91840	(4) SCREW, sheet metal, #10 x 3/4"	--	--	--	4
	91834	SCREW, 10 - 32 x 1/2"	--	1	1	1
	91828	SCREW, #8 x 1/4"	--	1	1	1
44	91211	NUT, 5/16" 24, nylock	--	--	--	1
45	91111	(14) NUT, 1/4" - 28 nylock	--	--	--	14
	91833	NUT, 10 - 32	--	1	1	1
46	91202	(2) WASHER, 5/16" SAE	--	--	--	2
47	91102	(18) WASHER, 1/4" SAE	--	--	--	18
	91832	(2) WASHER, #10 Tooth Lock	--	2	2	2
48	92010	FITTING, Tee	--	1	1	1
49	92011	FITTING, 1/4" Hose x 1/8" NPT	--	1	1	1
50	92120	FITTING, 1/8" NPT x 3/16" Hose	--	1	1	1
51	92122	FITTING, 1/8" NPT x 1/4" Hose, 90°	--	1	1	1
52	92303	(2) FITTING, Female, 90	--	2	2	2
53	92301	FITTING, Male, Straight	--	1	1	1
	62020	TERMINAL, Fast On	--	1	1	1
	62024	TERMINAL, Ring	--	1	1	1
	62034	CONNECTOR, Wire Tap	--	1	1	1
	62030	(2) CONNECTOR, Butt	--	2	2	2
	62038	TAP, Fuse, Blade	--	1	1	1
	62039	TAP, Fuse, Mini Blade	--	1	1	1
	62037	TAP, Fuse, Standard	--	1	1	1
	62210	ASSEMBLY, Wire Bypass		1	1	1
	62080	WIRE, 18 Gauge, Red, 6 feet	--	1	1	1
	62082	WIRE, 18 Gauge, Black, 6 feet	--	1	1	1
	62001	(6) TIES, Cable	--	6	6	6
	96328	OWNERS MANUAL	1	1	1	1
	96392	CARD, Product Registration	1	1	1	1
	96503	WARRANTY STATEMENT	1	1	1	1
54	96009	(2) UROCAL, "Banks Power"	2	2	2	2
		DECAL, Do Not Discard	--	1	1	1

\* Git-Kit uses P/N 52164, all other systems use 52154

\*\* P/N varies by vehicle

Gale Banks Engineering  
 546 Duggan Avenue • Azusa, CA 91702  
 (626) 969-9600 • Fax (626) 334-1743

Product Information & Sales: (800) 438-7693

**bankspower.com**