

**banks**

with Installation Instructions

# Owner's Manual

## **Banks Bullet™ Diesel Tuner**

**2003-2007 Ford Power Stroke  
6.0L Turbo-Diesel**

THIS MANUAL IS FOR USE WITH KITS 66524-66525

Gale Banks Engineering  
546 Duggan Avenue • Azusa, CA 91702  
(626) 969-9600 • Fax (626) 334-1743

Product Information & Sales: (888) 635-4565

**bankspower.com**

**banks**

# Also Available from Banks Power



## **Banks IQ System (P/N 61151-61152)**

- 5" touchscreen interface that can control the Banks Diesel Tuner and/or SpeedBrake on the fly.
- Interchangeable gauge display, read and clear codes, monitor engine diagnostics, log data, time your vehicles runs and much more.

## **Banks Monster® Exhaust System Sport (P/N 48790-48793) Single and Dual (P/N 47285-47292, 47606-47609, 48783-48788)**

- Increases exhaust flow, cuts backpressure, lowers exhaust gas temperatures (EGTs) and increases power.

## **Banks Ram-Air Intake System (P/N 42155)**

- Increases your airflow over stock.
- Adds power, improves fuel economy, lowers EGTs and reduces smoke.

## **High-Ram Intake (P/N 42750-42751)**

- Increases flow and provides more uniform air distribution to the engine for more available power at a given boost level.

## **Banks Techni-Cooler® System (P/N 25974-25975)**

- Provides increased air flow to the engine by increasing air density for more increased power, lower EGTs and improved fuel economy.

## **Banks Brake (P/N 55467-55468)**

- Increases the stopping power of your truck and extends the service life of your brakes

## **Boost and Pyro Gauges (P/N 64507)**

- Keep your engine safe by monitoring vital engine parameters

**Banks Billet Torque Converter  
(P/N 72522)**

- Higher torque capacity over stock
- Lockup clutch is slip-resistant so transmission fluids stay cooler and transmission life is prolonged.

**Banks SpeedBrake  
iQ Compatible (P/N 55455-55456)  
PDA Compatible (P/N 55457-55458)**

- Allows for controlled hill decent at a user defined vehicle speed.

**Banks Diesel Tuner  
Six-Gun w/ switch (P/N 61023)  
Six-Gun w/ iQ (P/N 63749)  
EconoMind w/ switch (P/N 63743-63745)**

**EconoMind w/ iQ (P/N 63747-63748)**

- Adds power safely to your vehicle
- Engine and transmission safeguards
- Change power levels on-the-fly

**Banks Speed-Loader  
(P/N 62988)**

- Furthers the power output of the Banks Six-Gun and provides EGT limiting safety.

**Thermocouple**

- Add a temperature limiting function to your Diesel Tuner

**OttoMind Programmer  
(P/N 66064)**

- Contains Banks tunes that boost your vehicles HP, Torque and MPG.
- Displays a host of critical engine functions
- Provides "service technician" diagnostic capabilities
- Has upgradeable functionality, so it will never be out of date

**Banks Stinger Systems  
(P/N 46465-46486)**

**Contains:**

- Ram-Air Intake system
- Monster Exhaust (single or dual)
- EconoMind Tuner w/ Banks iQ

**Banks PowerPack Systems  
(P/N 46497-46519)**

**Contains:**

- Ram-Air Intake system
- Monster Exhaust (single or dual)
- EconoMind Tuner w/ Banks iQ
- High-Ram
- Techni-Cooler System

**Banks Six-Gun Bundle  
(P/N 46594-46613)**

**Contains:**

- Ram-Air Intake system
- Monster Exhaust (single or dual)
- Six-Gun Tuner w/ Banks iQ

**Banks Big Hoss Bundle  
(P/N 46623-46643)**

**Contains:**

- Ram-Air Intake system
- Monster Exhaust (single or dual)
- Six-Gun Tuner w/ Banks iQ
- Big Head Wastegate Actuator
- High-Ram
- Techni-Cooler System

**For More Information please call (800) 438-7693  
or Visit us online @ [www.bankspower.com](http://www.bankspower.com)**

**THIS IS A HIGH PERFORMANCE PRODUCT. USE AT YOUR OWN RISK.**

**Do not use this product until you have carefully read the following agreement.**

**This sets forth the terms and conditions for the use of this product. The installation of this product indicates that the BUYER has read and understands this agreement and accepts its terms and conditions.**

## **Disclaimer of Liability**

Gale Banks Engineering Inc., and its distributors, employees, and dealers (hereafter "**SELLER**") shall in no way be responsible for the product's proper use and service. The **BUYER** hereby waives all liability claims.

The **BUYER** acknowledges that he/she is not relying on the **SELLER's** skill or judgment to select or furnish goods suitable for any particular purpose and that there are no liabilities which extended beyond the description on the face hereof and the **BUYER** hereby waives all remedies or liabilities, expressed or implied, arising by law or otherwise, (including without any obligations of the **SELLER** with respect to fitness, merchantability, and consequential damages) whether or not occasioned by the **SELLER's** negligence.

The **BUYER** is responsible to fully understand the capability and limitations of his/her vehicle according to manufacturer specifications and agrees to hold the **SELLER** harmless from any damage resulting from the failure to adhere to such specifications.

The **SELLER** disclaims any warranty

and expressly disclaims any liability for personal injury or damages. The **BUYER** acknowledges and agrees that the disclaimer of any liability for personal injury is a material term for this agreement and the **BUYER** agrees to indemnify the **SELLER** and to hold the **SELLER** harmless from any claim related to the item of the equipment purchased. Under no circumstances will the **SELLER** be liable for any damages or expenses by reason of the use or sale of any such equipment.

The **BUYER** is responsible to obey all applicable federal, state, and local laws, statutes, and ordinances when operating his/her vehicle, and the **BUYER** agrees to hold **SELLER** harmless from any violation thereof.

The **SELLER** assumes no liability regarding the improper installation or misapplication of its products. It is the installer's responsibility to check for proper installation and if in doubt, contact the manufacturer.

The **BUYER** is solely responsible for all warranty issues from the automotive manufacturer.

## **Limitation of Warranty**

Gale Banks Engineering Inc. (hereafter "**SELLER**"), gives Limited Warranty as to description, quality, merchantability, fitness for any particular purpose, productiveness, or any other matter of **SELLER's** product sold herewith. The **SELLER** shall be in no way responsible for the product's open use and service and the **BUYER** hereby waives all rights except those expressly written herein. This Warranty shall not be extended or varied except by written instrument signed by **SELLER** and **BUYER**.

The Warranty is Limited to two (2) years from the date of sale and is limited solely to the parts contained within the

products kit. All products that are in question of Warranty must be returned shipping prepaid to the **SELLER** and must be accompanied by a dated proof of purchase receipt. All Warranty claims are subject to approval by Gale Banks Engineering Inc.

Under no circumstance shall the **SELLER** be liable for any labor charged or travel time incurred in diagnosis for defects, removal, or reinstallation of this product, or any other contingent expense.

Under no circumstances will the **SELLER** be liable for any damage or expenses incurred by reason of the use or sale of any such equipment.

## **IN THE EVENT THAT THE BUYER DOES NOT AGREE WITH THIS AGREEMENT:**

**The BUYER may promptly return this product, in a new and unused condition, with a dated proof-of-purchase, to the place-of-purchase within thirty (30) days from date-of-purchase for a full refund.**

**The installation of this product indicates that the BUYER has read and understands this agreement and accepts its terms and conditions.**

## **Table of Contents**

<b>General Installation Practices . . . .</b>	<b>8</b>
<b>Section 1 . . . . .</b>	<b>10</b>
Exhaust Gas Thermocouple Installation Instructions	
<b>Section 2 . . . . .</b>	<b>12</b>
Installation of Wiring Harness, Connections and Banks Bullet Diesel Tuner	
<b>Section 3 . . . . .</b>	<b>19</b>
Operation of the Banks Bullet Diesel Tuner	
<b>Section 4 . . . . .</b>	<b>22</b>
Troubleshooting	
<b>Section 5 . . . . .</b>	<b>23</b>
Placement of the Banks Power Decals	

**Dear Customer,**

**If you have any questions concerning the installation of your Banks Bullet Diesel Tuner, please call our Technical Service Hotline at (888) 839-2700 between 7:00am and 5:00pm (PST). If you have any questions relating to shipping or billing, please contact our Customer Service Department at (888) 839-5600.**

**Thank you.**

The Banks Bullet Diesel Tuner has 3 power levels adjustable via controls on the interface module. Level 1 is stock, Level 2 is towing and Level 3 is sport.

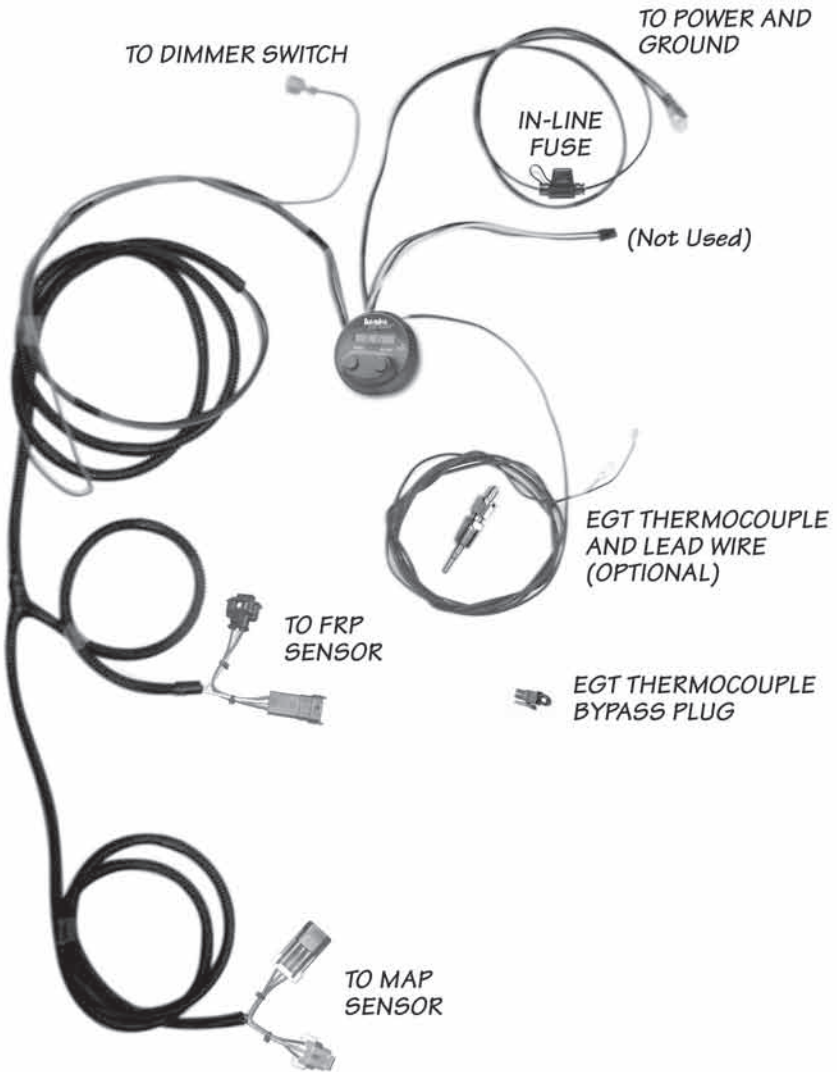
To prevent damage to the factory transmission, Banks recommends that both automatic and manual transmission vehicles do not exceed Level 2 while the vehicle is experiencing load (towing, climbing a steep grade, carrying a load, etc.).

To use the higher levels of the Bullet Diesel Tuner while towing or climbing, airflow improvements must be made to lower the exhaust gas temperature (EGT) entering the turbocharger's exhaust turbine. The EGT should not exceed 1300° F (1050° F if measured at the turbine outlet) for more than a few seconds. Elevated EGT can damage the turbocharger and engine.

## **Attention!**

**Before proceeding with these instructions, please carefully read the DISCLAIMER OF LIABILITY and LIMITATION OF WARRANTY statement located on page 4 of this manual.**

## Bullet and Supplied Wiring Harness



# General Installation Practices

**1.** Before starting work, familiarize yourself with the installation procedure by reading all of the instructions.

**2.** The exploded views provide only general guidance. Refer to each step and section diagram in this manual for proper instruction.

**3.** Throughout this manual, the left side of the vehicle refers to the driver side, and the right side to the passenger side.

**4.** Disconnect the negative (ground) cable from the battery (or batteries, if there are two) before beginning work.

**5.** Route and tie wires and hoses a minimum of 6" away from exhaust heat, moving parts and sharp edges. Clearance of 8" or more is recommended where possible.

**6.** When raising the vehicle, support it on properly weight-rated safety stands, ramps or a commercial hoist. Follow the manufacturer's safety precautions. Take care to balance the vehicle to prevent it from slipping or falling. When using ramps, be sure the front wheels are centered squarely on the topsides. When raising the front of the vehicle, put the transmission in park (automatic) or reverse (manual), set the parking brake, and block the rear wheels. When raising the back of the vehicle, be sure the vehicle is on level ground and the front wheels are blocked securely.

**CAUTION: Do not use floor jacks to support the vehicle while working under it. Do not raise the vehicle onto concrete blocks, masonry or any other item not intended specifically for this use.**

**7.** During installation, keep the work area clean. Do not allow anything to be dropped into intake, exhaust, or lubrication system components while performing the installation, as foreign objects will cause immediate engine damage upon start-up.

**8.** Save this Owner's Manual as a reference for system maintenance and service.

**9.** Banks also recommends the following airflow improvements (see Recommended Airflow Improvements page 9) to maintain safe engine operating conditions and provide increased power gains.

## Tools Required:

- Standard and Metric sockets and wrenches
- Standard and Phillips screwdrivers
- Foot-pound torque wrench
- Drill motor
- 3/16" Drill bit
- 7/16" Drill bit
- 1/4" NPT tap and tap handle

## Highly recommended tools and supplies:

- Penetrating oil or light lubricant spray
- Heatgun

## Recommended Airflow Improvements

Banks Monster® Exhaust	
'03 F-250/350 Pickup	
Ext cab, short bed.....	48764
'04-07 F-250/350 Pickup	
Ext cab, short bed.....	48784
'03 F-250/350 Pickup	
Ext cab, long bed .....	48766
'04-07 F-250/350 Pickup	
Ext cab, long bed .....	48786
'03 F-250/350 Pickup	
Crew cab, short bed .....	48765
'04-07 F-250/350 Pickup	
Crew cab, short bed .....	48785
'03 F-250/350 Pickup	
Crew cab, long bed .....	48767
'04-07 F-250/350 Pickup	
Crew cab, long bed.....	48787
'03 Excursion.....	48768
'04-07 Excursion .....	48788
TechniCooler®	
2003-04 .....	25974
2005-07 .....	25975
Ram-Air® Intake System	
2003-07 .....	42155
Service Kit .....	90094
Gauge Assembly, Boost and Pyro	
2001-2007 .....	64507
Gauge Holder	
2-Gauge pillar .....	63305
3-Gauge pillar .....	63306
Thermocouple .....	63055
Lead Wire .....	63060

# Section 1

## EXHAUST GAS THERMOCOUPLE INSTALLATION INSTRUCTIONS

*NOTE: If not installing or connecting an EGT thermocouple to the Banks Bullet Diesel Tuner then install the supplied EGT thermocouple bypass plug. The bypass plug is installed on the two-pin connector attached to the backside of the Banks Bullet.*

*-If your vehicle has a Banks DynaFact EGT probe installed, please **skip to step 11.***

*-If your kit does not have EGT sensing and limiting functions, please **skip to Section 2.***

### INSTALLATION

**1.** The thermocouple monitors the temperature of the exhaust gases entering the turbocharger at the turbine housing. Installation requires that the exhaust manifold be drilled near the manifold outlet. It is recommended that the manifold be removed from the engine to thoroughly clean out all metal chips from drilling. All metal shavings must be cleaned from the manifold to avoid turbine wheel damage and possible interference with the turbocharger's variable geometry turbine stage.

**2.** Disconnect the Exhaust Back Pressure Sensor tap located at the front of the driver side manifold. The pressure tap must be removed by using a  $\frac{9}{16}$ " open-end wrench to hold the fitting stationary, and loosen the tube using a  $\frac{5}{8}$ " open-end wrench. The fitting is shown in **Figure 1**. *Note: Failure to hold the fitting stationary will damage the tube upon removal.*

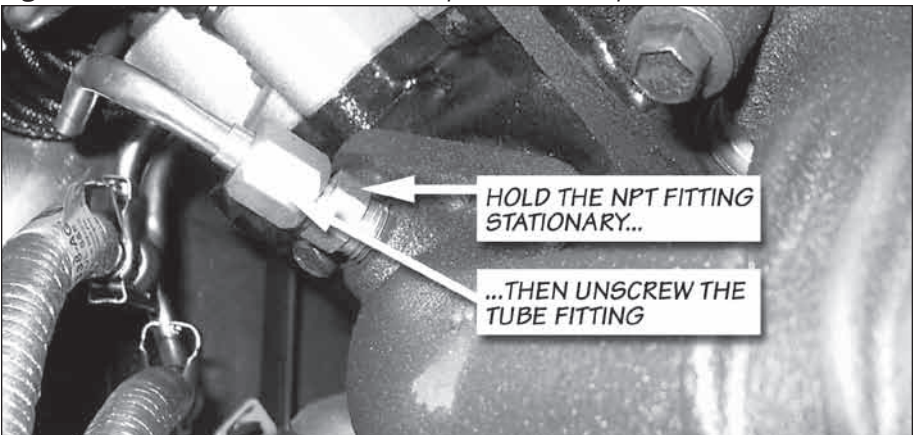
**3.** Remove the driver side exhaust manifold.

**4.** Drill a  $\frac{7}{16}$ " hole in the driver side exhaust manifold at the location shown in **Figure 2**.

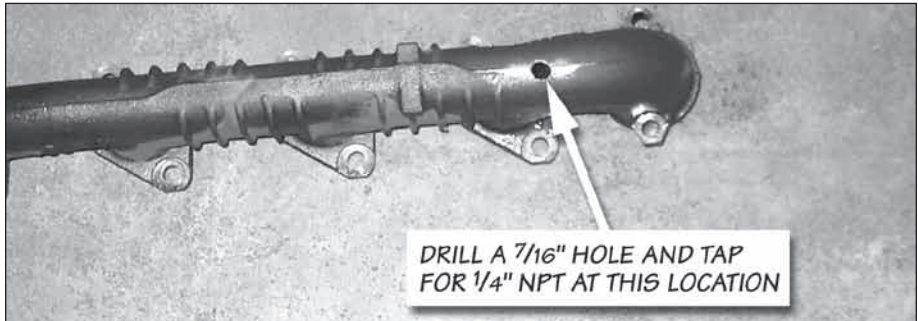
**5.** Tap the hole for a  $\frac{1}{4}$ " NPT thread. Check the thread depth as you tap by periodically removing the tap and screwing the pipe coupling into the tapped hole. The coupling should thread in 3 to  $3\frac{1}{2}$  turns hand tight. Do not install the probe in place at this time. **Caution: Running the tap too deeply can prevent the pipe fitting from properly sealing.**

**6.** Remove the NPT fitting from the thermocouple and install it on the exhaust manifold. Use anti-seize lubricant on the threads and torque to 14–16 lb-ft.

**Figure 1:** Location of the static exhaust pressure line tap

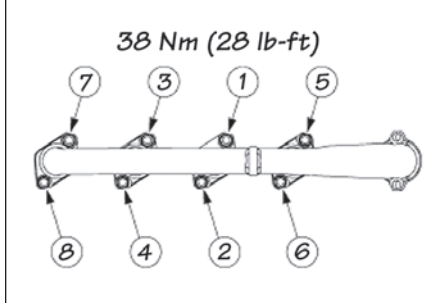


**Figure 2:** Location to drill and tap the driver side exhaust manifold for the thermocouple

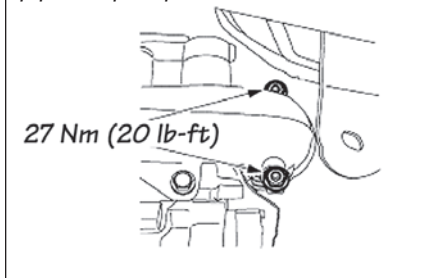


**7.** Remove all metal chips from the exhaust manifold. *Note: Failure to remove all metal chips could result in catastrophic damage to the turbocharger's turbine wheel or interfere with the operation of the variable geometry vane mechanism.*

**Figure 3:** Exhaust manifold tightening sequence



**Figure 4:** Turbocharger adapter pipe torque specification



**8.** Re-install the exhaust manifold. Apply anti-seize lubricant to the manifold bolt threads and torque to 28 lb-ft. Use the tightening sequence shown in **Figure 3**.

**9.** Tighten the turbocharger adapter pipe fasteners to 20 lb-ft as shown in **Figure 4**.

**10.** Reconnect the Exhaust Back Pressure Sensor tap.

**11.** Attach the thermocouple to the supplied thermocouple lead wire extension with the supplied nuts and bolts. Route the thermocouple lead wire extension along the factory harness to the driver's side and connect it to the Bullet harness with the supplied nuts and bolts. The **YELLOW** thermocouple wire attaches to the **YELLOW** extension wire's, the **RED** thermocouple wire attaches to the **RED** extension wire. Cover this joint with the supplied heat shrink tubing and heat until the tubing conforms to the joint. Make sure the entire joint is insulated.

**12.** Route the thermocouple to the exhaust manifold and install the thermocouple in the fitting.

**13.** Refer to **Section 2** for instructions on routing the thermocouple lead wire to the Banks Bullet Module

-END, SECTION 1-

## Section 2

### INSTALLATION OF WIRING HARNESS, CONNECTIONS AND BANKS BULLET DIESEL TUNER

**1.** Disconnect the battery ground cables from each of the batteries. Secure the cables so that they do not come in contact with the battery posts during the installation.

**2.** Locate the Manifold Absolute Pressure (MAP) sensor. Unplug the factory connector and plug it into the corresponding male MAP sensor connector on the Banks Bullet harness. Plug the Banks Bullet's female MAP sensor connector into the sensor. See **Figure 5**.

*-For model year 2003 follow steps 3 through 5.*

*-For Model year 2004-2007 follow steps 6 and 7.*

#### **MODEL YEAR 2003**

**3.** To access the Injection Control Pressure (ICP) sensor on a 2003 model year truck, a heat shield at the (rear)

of the engine must be removed. The heat shield is accessible from beneath the vehicle. The heat shield is secured with one, 13mm and two, 10mm bolts. See **Figure 6**.

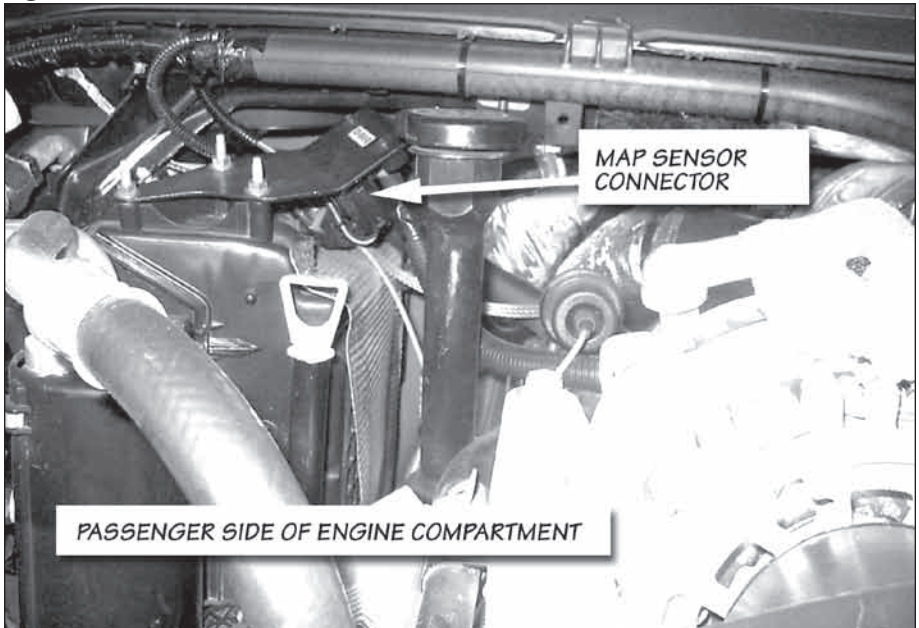
**4.** Once the heat shield is removed, locate the ICP sensor. Unplug the factory connector and plug it into the corresponding male ICP sensor connector on the Banks Bullet harness. Plug the Banks Bullet's female ICP sensor connector into the sensor. See **Figure 7**.

**5.** Reinstall turbocharger heat shield. Skip to Step 8.

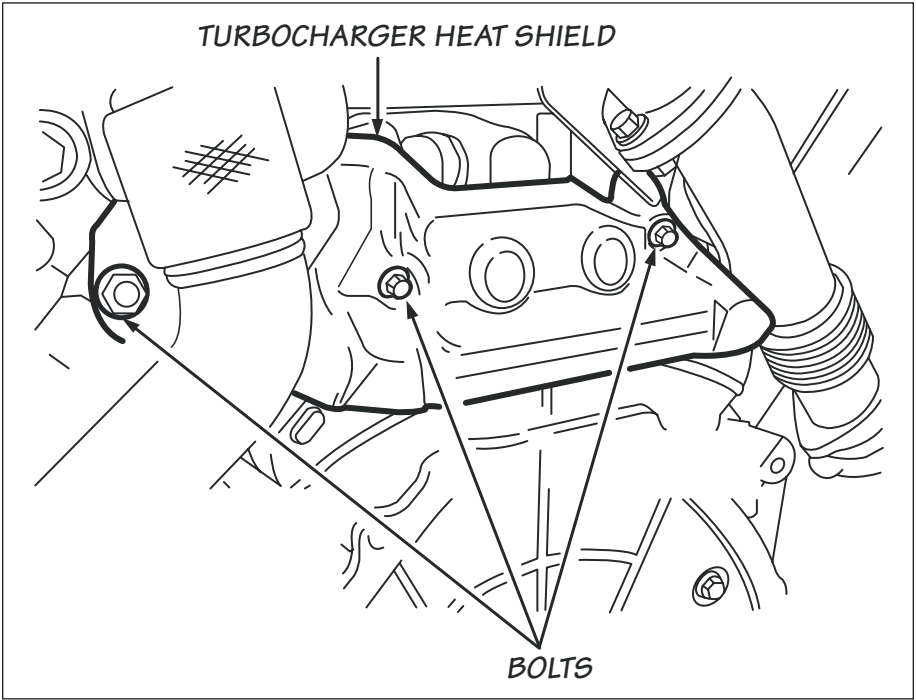
#### **MODEL YEAR 2004- 07**

**6.** Locate the Injection Control Pressure (ICP) sensor located on the right side of the engine between the compressor boost tube and the alternator. See **Figure 8**.

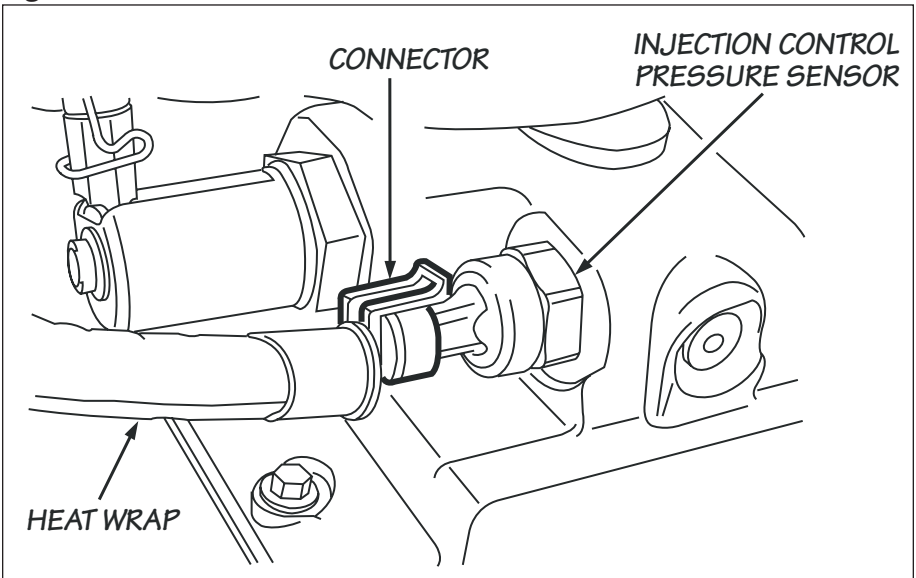
**Figure 5**



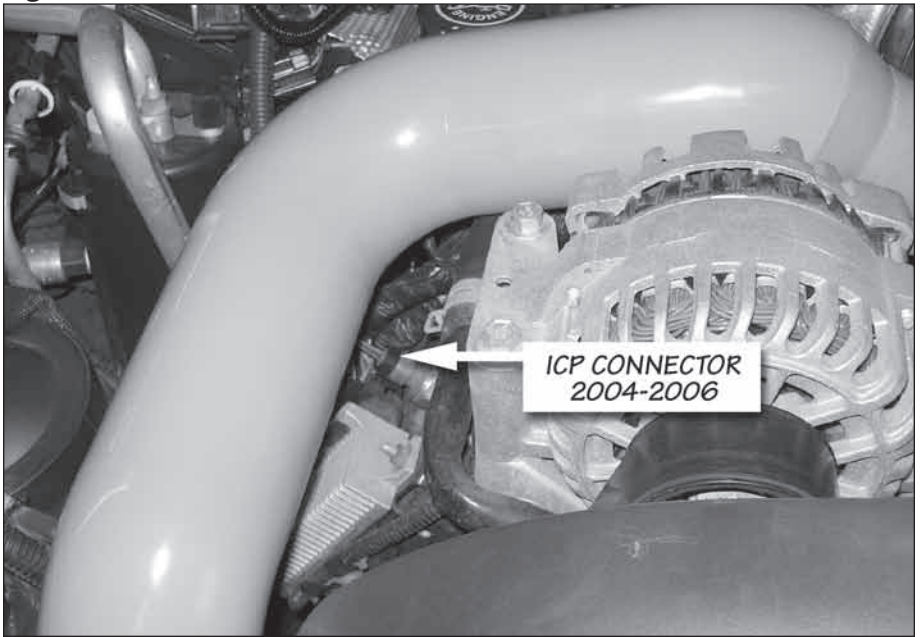
**Figure 6** 2003 Model



**Figure 7** 2003 Model



**Figure 8** 2004-2007 Model



**7.** Unplug the factory connector and plug it into the corresponding male ICP sensor connector on the Banks Bullet harness. Plug the Banks Bullet's female ICP sensor connector into the sensor.

**8.** Route the harness from the MAP and ICP sensor as shown in **Figure 9**. Use the supplied zip ties to secure the harness to the factory harness.

*Note: Failure to follow the recommended harness routing may result in a melted harness.*

**9.** Route the Banks Bullet wire harness (and EGT thermocouple lead wire harness, if so equipped) through the firewall to the passenger compartment, leaving enough slack harness length in the engine bay to allow for engine movement without straining the sensor connectors.

**10.** Remove the lower driver side interior panel that allows access to the

fuse box.

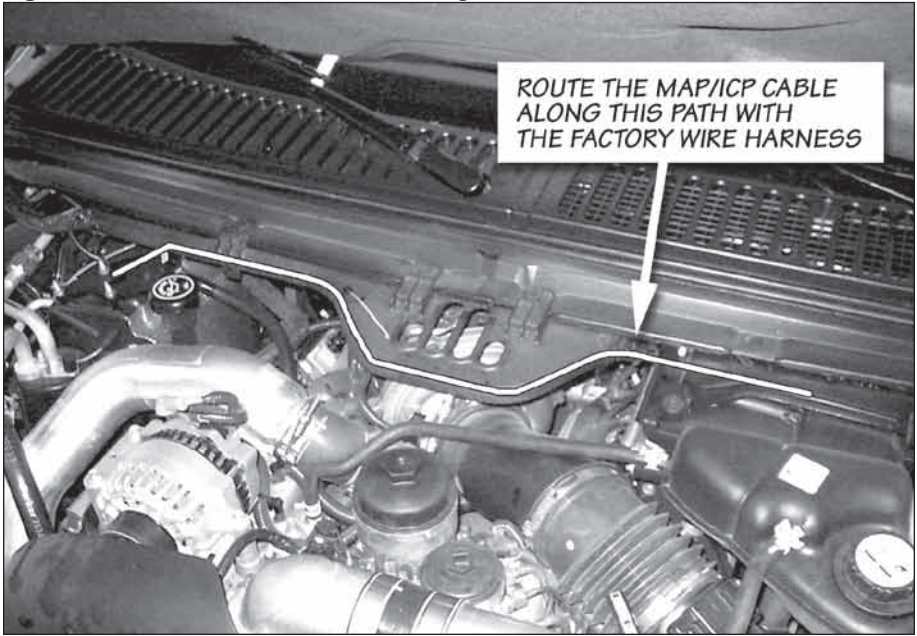
**11.** Carefully remove the dashboard panel. Remove the panel by prying as shown in **Figure 10**, on the right hand corner. Next, unclip the headlamp control panel connector.

**12.** With the headlight control panel connector removed, place one of the supplied snap-on wire taps onto the BLUE wire with RED stripe. See **Figure 11**.

*Note: Be sure that the wiretap snaps closed securely – firmly squeezing it shut with a pair of pliers will help ensure a proper electrical connection.*

**13.** Locate the Banks Bullet wiring harness where it passes through the firewall. Route the **ORANGE** wire with the shielded male connection tab up behind the dash and to the back of the headlight control panel. Plug the male connector tab into the wire tap installed in the previous step, then

**Figure 9:** MAP/ICP sensor harness routing



**Figure 10**



**Figure 11**

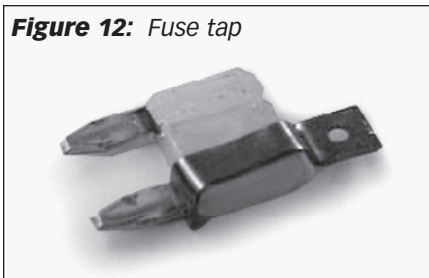


reinstall the headlight control panel connector into the dash. (The headlight control panel should push easily in and snap back into place – if it does not, look for kinked or pinched wiring.)

**14.** Remove the fuse box cover, located in the cabin compartment. Locate **mini-fuse #22** and remove.

Install the mini-auto blade fuse tap onto the removed mini fuse as shown in **Figure 12**. Re-install the mini fuse with the attached blade tap into **location #22** as shown in **Figure 13**.

**Figure 12:** Fuse tap



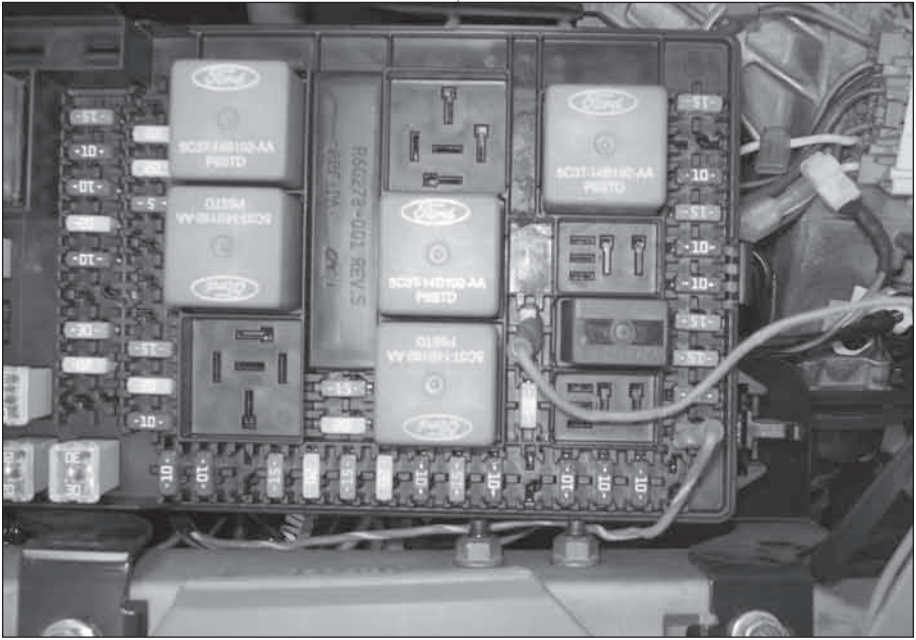
**15.** Locate the RED single terminal connector on the Banks harness and connect it to the mini-fuse blade tap location #22. Replace the fuse cover and make sure not to pinch the RED single terminal wire.

*Note: Make sure the inline fuse holder is routed outside the factory fuse box.*

**16.** Locate the BLACK ground wire with the ring terminal on the Banks Bullet wire harness. Install ring terminal on top of existing ring terminals and re-install the screw. See **Figure 14**.

**17.** Route the 6-pin connector from the Banks Bullet harness, the 10-pin connector from the power harness, and the two-pin connector from the EGT thermocouple leadwire (if so equipped) to the back of the Banks Bullet module and plug them in.

**Figure 13**



**Figure 14**



**18.** If using a module mounting method other than the supplied bracket, complete the mount installation per the supplied directions. Double-check all wire harness routing for proper clearance around moving and sharp objects as well as heat sources, then use the supplied nylon tie straps to secure the wire harnesses safely away from any control linkages and the operator's feet underneath the dashboard.

**19.** Re-attach any previously removed interior trim panels, re-connect the negative battery cables and lower the

vehicle. Start the vehicle, checking for normal engine operation and listening carefully for exhaust leaks and rattles. Re-torque any exhaust manifold fasteners as needed.

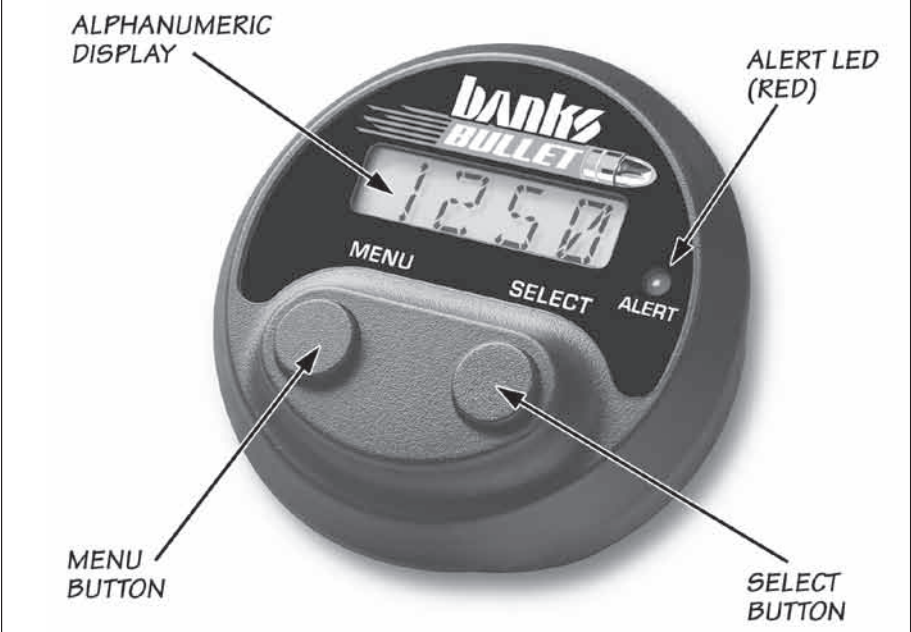
*Note: Go over the entire installation as a precautionary check to ensure that all clamps are tight, wiring and hoses are properly routed, and connections are correct and tight. Make sure that the Bullet wire harness is not lying in the way of the brake and gas pedals, or any moving parts.*

-END, SECTION 2-

# Section 3

## OPERATION OF THE BANKS BULLET DIESEL TUNER

**Figure 15:** Banks Bullet module controls



If your Banks Bullet Diesel Tuner module has been properly installed as outlined in the previous section, it will power up and briefly scroll **'BANKS POWER'** across the screen, then display the current power level setting after you switch your ignition key on.

If the Bullet module detects any errors in installation wiring, sensor readings, or internal hardware functions, it will flash a message with the detected errors immediately after displaying the current power level setting. Please refer to the following section, 'Troubleshooting', for a full explanation of the error codes, their causes, and corrective actions.

*NOTE: The Bullet module will automatically detect an EGT thermocouple when one is properly connected, and will configure the available menus accordingly. If you do not have a Banks EGT thermocouple*

*installed and properly connected to the Bullet module, none of the EGT-related menus will be displayed.*

If the Bullet module does not detect any errors in the system, it will monitor and display the selected default engine parameter in the following format:

- Boost is displayed in PSI – the letter '**B**' and one or two digits
- EGT is displayed in degrees Fahrenheit – three or four digits with no prefacing letter
- Fuel amount is displayed as a percentage of stock fuel amount entering the engine – the letter '**F**' and three digits
- VER displays the tuner part number and current firmware/calibration version

This is the Bullet module's normal display mode. Power level selection, EGT

limiting, display options and diagnostics information are all accessed by pressing the 'MENU' button on the face of the module.

### Setting Desired Power Level:

To set the desired power level from the normal display mode, press the 'MENU' button until 'PWR' is displayed, then press the 'SELECT' button.

The current power level setting will be displayed – press the 'SELECT' button to continue operating at this power level and return to normal operating mode (the module will display a 'SAVED' message confirming your selection), or press the 'MENU' button to cycle through power levels 'STK' (stock), 'TOW' (tow) and 'SPT' (sport).

Press 'SELECT' when your desired power level is displayed, and the Bullet module will instantly make the necessary corrections to engine fueling, display a 'SAVED' message confirming your selection, and return to the normal display mode. If no buttons are pressed within five (5) seconds, the module will return to the standard display mode without saving any changes.

### Quick Power Level Changes:

Power levels can also be quickly changed at any time from the normal display mode by pressing the 'SELECT' button. The currently selected power level will be displayed – pressing the 'SELECT' button again within five (5) seconds will increase the power level by one; repeatedly pressing the 'SELECT' button will cycle through power levels 'STK' - 'SPT'.

Pressing the 'MENU' button will set the currently displayed power level as the new operating level, and display a 'SAVED' message before returning to the normal display mode. If no buttons are pressed within five (5) seconds, the module will return to the standard display mode without saving any changes.

### Setting Desired Maximum EGT Limit:

To set the desired maximum EGT limit and alarm level from the normal display mode, press the 'MENU' button until 'TLMT' is displayed, then press the 'SELECT' button.

The current EGT limit will be displayed, in degrees Fahrenheit (the default value is 900 °F). Press the 'SELECT' button to continue operating with this EGT limit and return to normal operating mode (the module will display a 'SAVED' message confirming your selection), or press the 'MENU' button to cycle through all available EGT limit options from 800 °F to 1500 °F, in 50 degree increments.

Press the 'SELECT' button when your desired maximum EGT limit is displayed, and the Bullet module will save your selection, display a 'SAVED' message, and return to the normal display mode. If no buttons are pressed within five (5) seconds, the module will return to the standard display mode without saving any changes.

The Bullet module will now limit the measured EGT at or below this value as much as possible by reducing the amount of extra fuel that it injects into the engine. In addition, if the measured EGT increases 50 degrees past the selected limit, an alarm will trigger and illuminate the warning light as well as flashing the current EGT value on the display.

**WARNING: If the Bullet Diesel Tuner is installed in tandem, or 'stacked' with another performance module that modifies the amount of fuel injected into the engine, the Bullet module may not be able to control EGT within the set limit as it is not able to control the functions of the secondary performance module.**

**ALWAYS CAREFULLY MONITOR YOUR EGT WHEN RUNNING STACKED PERFORMANCE MODULES.**

### **Setting Default Display Options:**

To set the desired default display parameter from the normal display mode, press the 'MENU' button until '**DISP**' is displayed, then press the 'SELECT' button.

The currently selected engine parameter is displayed – to continue operating with this parameter displayed by default on the Bullet module, press the 'SELECT' button – a '**SAVED**' message will be displayed and the module will return to the normal display mode. To cycle through the available parameter display options, press the 'MENU' button. '**EGT**' will display the Exhaust Gas Temperature from the thermocouple (if installed); '**BST**' will display boost (manifold) pressure; '**FUEL**' will display the amount of fuel entering the engine as a percentage of the stock fuel amount. '**VER**' will display tuner part number and current firmware/calibration version.

Press the 'SELECT' button to set the currently displayed engine parameter as the default display parameter – the Bullet module will save your selection, display a '**SAVED**' message, and return to the normal display mode where the parameter you have just selected will

now be displayed on the module. If no buttons are pressed within five (5) seconds, the module will return to the standard display mode without saving any changes.

### **Setting the Boost Level Set Point:**

To set the boost level at which the Bullet module will trigger a visual alarm warning you of a high boost condition, press the 'MENU' button while in the normal display mode until '**B SP**' is displayed, then press the 'SELECT' button.

The current Boost Level Set Point will be displayed, in PSI (the default value is 50 PSI). Press the 'SELECT' button to continue operating with this Boost Level Set Point and return to normal operating mode (the module will display a '**SAVED**' message confirming your selection), or press the 'MENU' button to cycle through all available Boost Level Set Point options from 20 PSI to 50 PSI, in 1 PSI increments.

Press the 'SELECT' button when your desired Boost Level Set Point is displayed, and the Bullet module will save your selection, display a '**SAVED**' message, and return to the normal display mode. If no buttons are pressed within five (5) seconds, the module will return to the standard display mode without saving any changes.

**Note: In the normal display mode 'T SP' (Transmission Temperature Set Point) is a non-functioning setting for this model vehicle. This menu will still be accessible and editable, but the settings it contains will not have any affect on the Bullet diesel tuner. Please disregard this setting.**

-END, SECTION 3-

# Section 4

## TROUBLESHOOTING

The Bullet Diesel Tuner is equipped with self-diagnosing features that automatically check for proper sensor and module operation. Error codes that your module may display, either upon startup or after accessing the Diagnostics submenu, are listed below.

If the Bullet Diesel Tuner should ever

need to be removed from the vehicle, the system includes a bypass plug that must be connected to the six-pin MAP/ICP harness in place of the module. Failure to utilize the bypass plug when the Bullet module has been unplugged from the harness will generate a Check Engine light when attempting to start the vehicle.

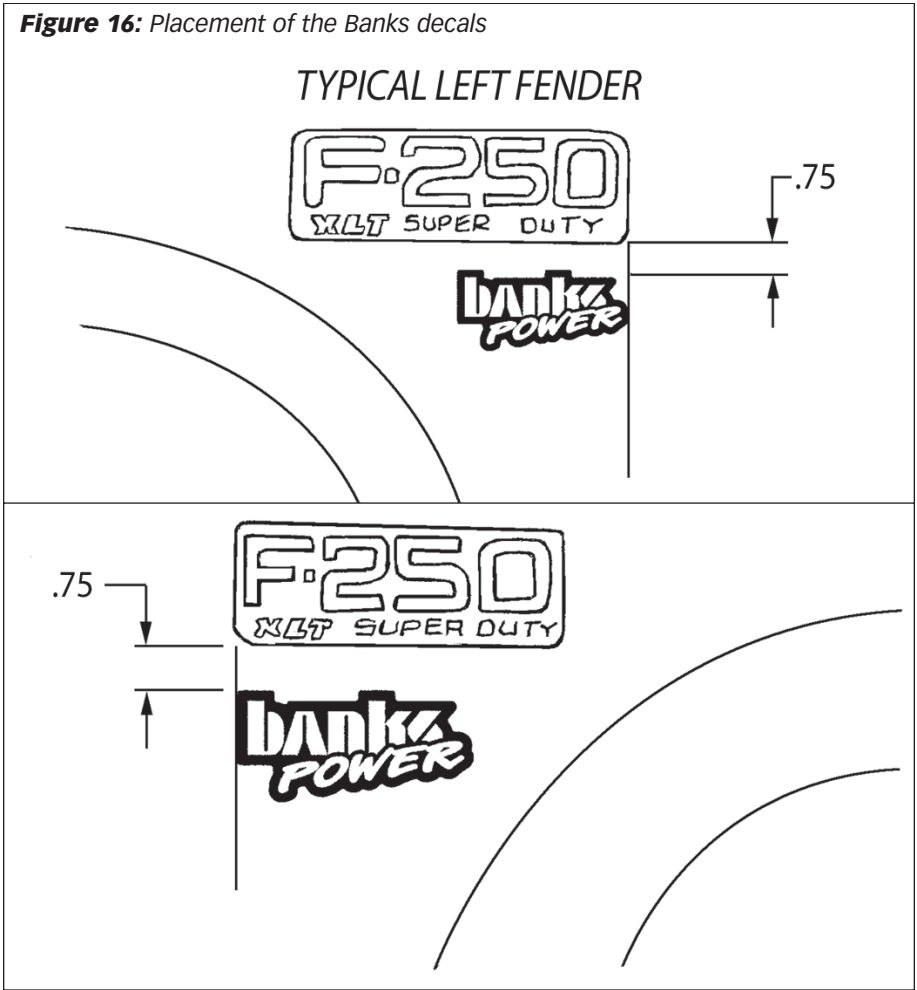
-END, SECTION 4-

<b>Table 2</b>		
<b>Error Code</b>	<b>Code Description</b>	<b>Course of Action</b>
<b>BST ERR1</b>	The Bullet module has detected a fault in the Manifold Absolute Pressure (MAP) input circuit.	The listed error code(s) will occur when the Bullet module fails to receive any signal from the associated sensor, or receives an input signal from the sensor that is out of the normal operating range.
<b>ICP ERR2</b>	The Bullet module has detected a fault in the Injection Control Pressure (ICP) input circuit.	
<b>EGT ERR3</b>	The Bullet module has detected a fault in the Exhaust Gas Temperature (EGT) input circuit.	Turn the vehicle and ignition completely off, check the Bullet harness connections at the sensor in question to ensure that they are fully engaged. Also check the 2- and 6-pin connectors at the back of the Bullet module to ensure that they are properly engaged. After checking all connections, restart the vehicle – if the Bullet module continues to display the same error message, please contact Banks Technical Service
<b>BSTO ERR4</b>	The Bullet module has detected a fault in the Manifold Absolute Pressure (MAP) output circuit.	The listed output error(s) will be displayed when the Bullet module detects a problem with the associated output signal.  Turn the vehicle and ignition completely off, check the Bullet harness connections at the sensor in question to ensure that they are fully engaged. Also check the 6-pin connector at the back of the Bullet module to ensure that it is properly engaged. After checking all connections, restart the vehicle – if the Bullet module continues to display the same error message, please contact Banks Technical Service.
<b>ICPO ERR5</b>	The Bullet module has detected a fault in the Injection Control Pressure (ICP) output circuit.	
<b>INT ERR6</b>	The Bullet module has detected an internal (module) error.	Turn the vehicle completely off then restart it – if the error is still present contact Banks Technical Service.

# Section 5

## PLACEMENT OF THE BANKS POWER DECALS

**Figure 16:** Placement of the Banks decals



-END, SECTION 5-

Gale Banks Engineering  
546 Duggan Avenue • Azusa, CA 91702  
(626) 969-9600 • Fax (626) 334-1743

Product Information & Sales: (888) 635-4565

**bankpower.com**