

OWNERS MANUAL

...with installation instructions

Banks Brake™ **EXHAUST BRAKE SYSTEM**

**1998-2002 Dodge ISB 5.9L Cummins
(24-valve) Turbo-Diesel Pickups**

THIS MANUAL IS FOR USE WITH SYSTEM 55219 & 55221

Gale Banks Engineering
546 Duggan Avenue • Azusa, CA 91702
(626) 969-9600 • Fax (626) 334-1743

Product Information & Sales: (800) 438-7693
bankspower.com

BANKS

Also Available from Banks Power

98-02 Dodge 5.9L



Banks Monster® Exhaust System
98-02 (P/N 48635-48638)

- Increases exhaust flow, cuts backpressure, lowers exhaust gas temperatures (EGTs) and increases Power

Banks Monster-Ram
98-02 (P/N 42764)

- Increased flow from intercooler
- Raises boost without increasing backpressure at the turbine

Banks SmartLock
98-02 (P/N 55262)

- Reduces wear on transmission
- Locks Torque Converter and raises trans-line pressure
- Works with Banks Exhaust Brake

Banks Diesel Tuner
98-02 Big Hoss (P/N 62781-62783)

- Adds power safely to your vehicle
- Engine and transmission safeguards
- Change power levels on-the-fly

Thermocouple

- Add a temperature limiting function to your Diesel Tuner

Banks QuickTurbo
94-02 (P/N 24052, 24053)

- More boost through the powerband
- Does not over-boost
- Turbo-diesel efficiency

Banks BigHead® Actuator
98-02 (P/N 24329)

- Achieves a higher peak boost over stock and gives you precise boost control that gives you crisp acceleration and more mid-range pulling power.

Banks Billet Torque Converter
94-07 (P/N 72515)

- Higher torque capacity over stock
- Lockup clutch is slip-resistant so transmission fluids stay cooler and transmission life is prolonged.

Banks Git-Kit Systems
98-02 (P/N 49357-49362)

- Contains:**
- Monster Exhaust
 - OttoMind Tuner

Banks Stinger Systems
98-02 (P/N 49363-49374)

Contains:

- Ram-Air Filter
- Monster Exhaust
- OttoMind Tuner
- Big Head Wastegate Actuator
- Gauges

Banks Stinger-Plus Systems
98-02 (P/N 49320-49323, 49351, 49352)

Contains:

- Ram-Air Filter
- Monster Exhaust
- OttoMind Tuner
- Big Head Wastegate Actuator
- Gauges
- Quick Turbo

Banks PowerPack Systems
98-02 (P/N 49330-49335, 49353-49356)

Contains:

- Ram-Air Filter
- Monster-Ram
- Monster Exhaust
- OttoMind Tuner
- Big Head Wastegate Actuator
- Gauges
- Quick Turbo

For More Information please call (888) 635-4565
 or Visit us online @ www.bankspower.com

Dear Customer,
Your new Banks Brake is a uniquely designed exhaust brake with electronic controls, designed to achieve the optimum level of braking from your vehicle's engine.

If you have any questions concerning the installation of the Banks Brake, please call our Technical Service Hotline at (888) 839-2700 between 7:00 am and 5:00 pm (PT). If you have any questions relating to shipping or billing, please contact our Customer Service Department at (888) 839-5600.

Thank you.

General Installation Practices

- 1.** For ease of installation of your Banks Brake, please read this 16-page Owner's Manual before starting any work. Become thoroughly familiar with all components and phases of the installation before beginning any work.
- 2.** Inspect all components supplied for any foreign material that may have entered during shipping and handling.
- 3.** Pay particular attention to the routing of wires and hoses. Keep them away from exhaust heat, moving parts and sharp edges that may cause cuts or other damage. Route or tie away from critical areas as required. Keep all wires a minimum of 6" from hot exhaust parts, 8" or more is recommended whenever possible.
Warning! Never work under any vehicle supported only by a jack of any kind. DO NOT USE concrete blocks or other masonry items that may collapse under the vehicle weight.

Brake Installation

1. As a precaution, disconnect the ground of the battery (if there is more than one battery, disconnect both).

2. Remove the air cleaner box assembly (including the black flex hose) from the passenger side of the vehicle.

3. Lift and support the vehicle.

4. If a Banks Stinger, Stinger-Plus or PowerPack is being installed now or is already installed on the vehicle, proceed to Step 6.

5. Underneath the vehicle, locate the alignment pin identified in **Figure 1**. Measure forward 29" and make a mark at the centerline of the pipe. Using a reciprocating saw or hacksaw, make a straight cut through the pipe at the indicated location.

Figure 1

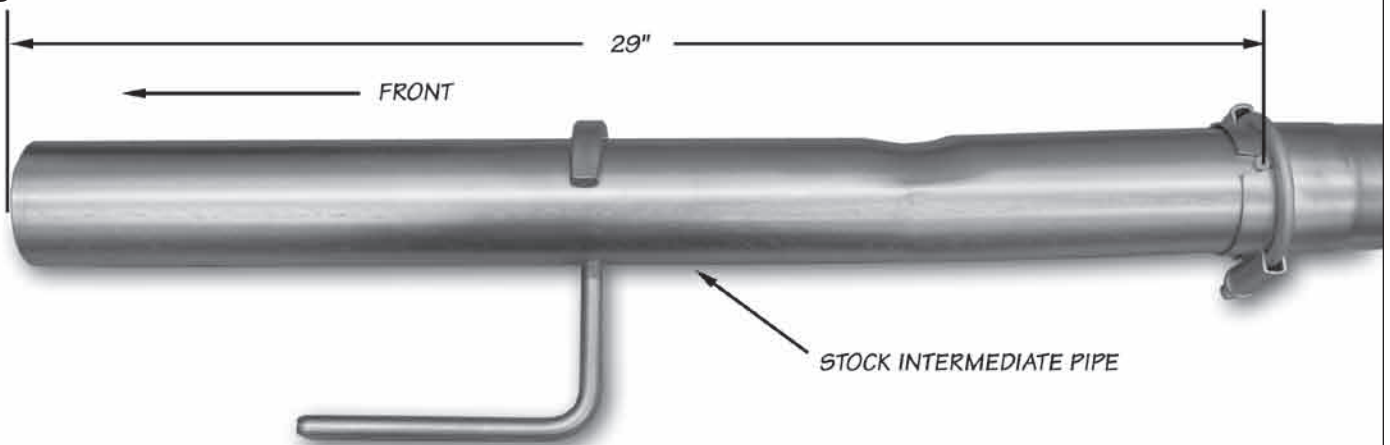

Figure 2

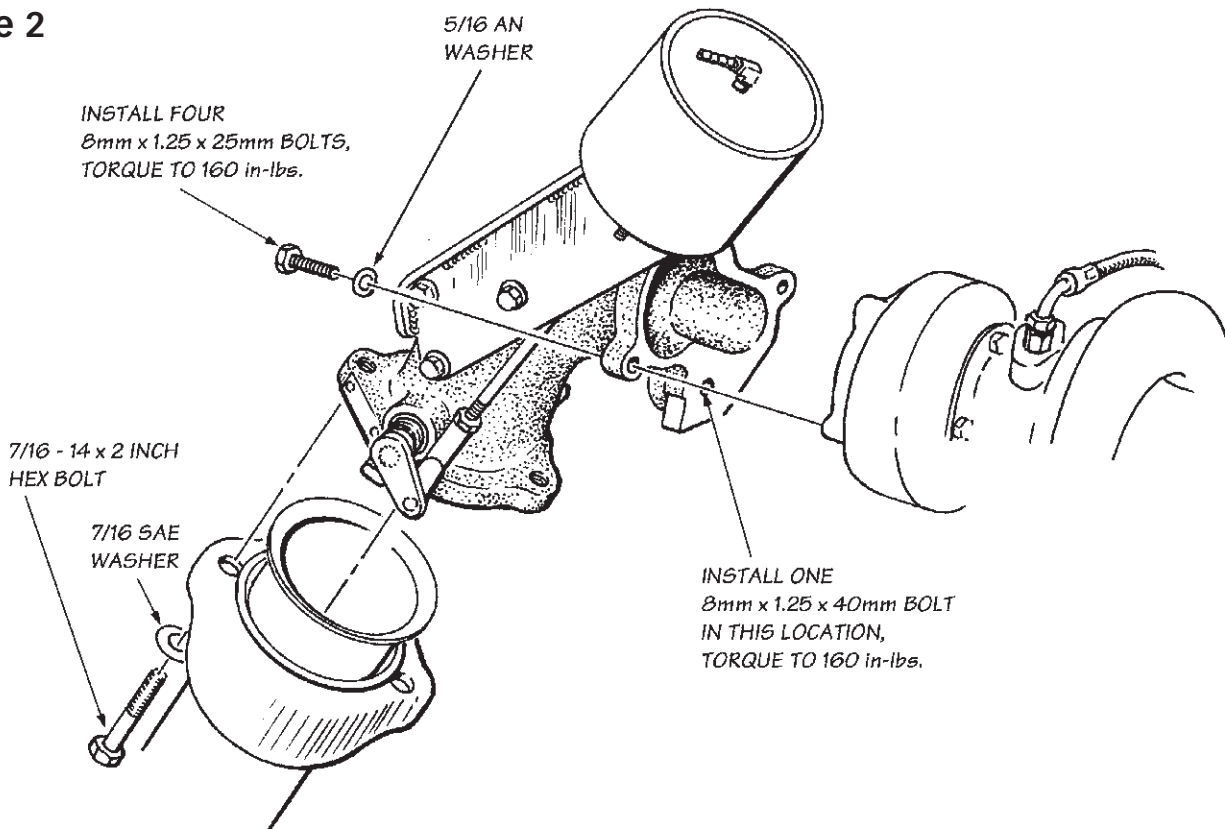

Figure 3

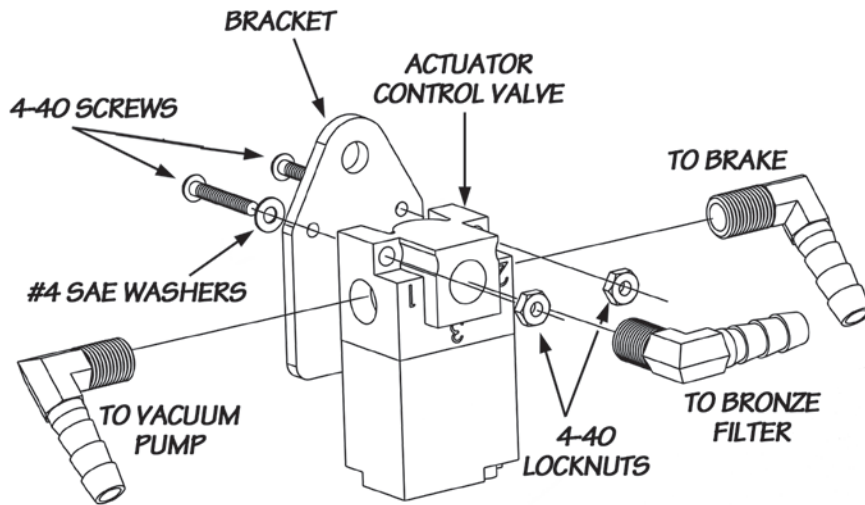
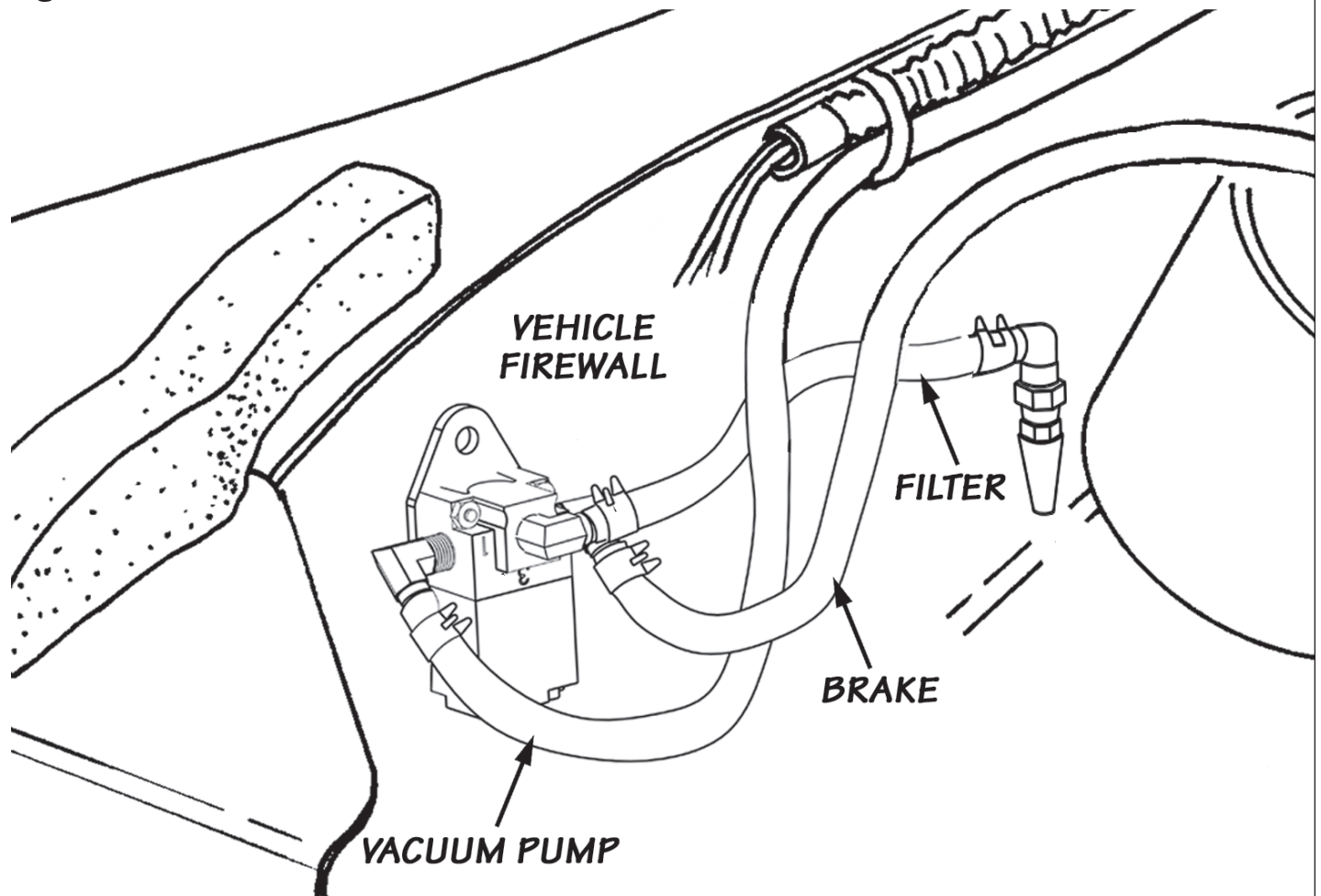

Figure 4



6. Locate the ball flange at the inlet of the turbine outlet pipe. Using a 13-mm socket, remove the two 10-mm bolts that attach the flange to the turbine outlet casting.

7. Remove the five 8-mm bolts that attach the exhaust elbow to the turbine outlet flange. Remove the elbow and gasket.

8. Underneath the vehicle, remove the upper portion of the turbine outlet pipe. *Note: When a Banks exhaust system is already installed on the vehicle, some heat may be required to expand the tubing and allow the turbine outlet pipe to be removed.*

9. Loosely install the new turbine outlet pipe to the existing intermediate pipe. Do not tighten any clamps at this time.

10. Install the Banks Brake assembly onto the outlet of the turbocharger using the five new 8-mm bolts and flat washers provided. See **Figure 2**. Do not re-use the stock turbine outlet gasket. The fully-machined mating surface on the Banks Brake does not require a gasket for adequate sealing. Use the supplied anti-seize compound on the bolts and tighten them evenly. The torque specification for these bolts is 160 in-lbs (**not ft-lbs**).

11. Tighten the two $\frac{7}{16}$ " bolts at the ball flange to 15 ft-lbs.

Note: Do not use an impact wrench on these fasteners. The wide span of the two-bolt spherical flange creates sufficient clamping force when 15 ft-lbs is used. Exceeding this torque specification will not increase the sealing performance.

12. Tighten the exhaust clamp that seals the turbine outlet pipe to the intermediate pipe.

13. Thread the 90-degree hose fittings provided into all three ports of the actuator control valve, as shown in **Figure 3**. Mount the valve to the bracket as shown using the two 4-40 screws, washers and nylock nut assemblies.

Figure 5

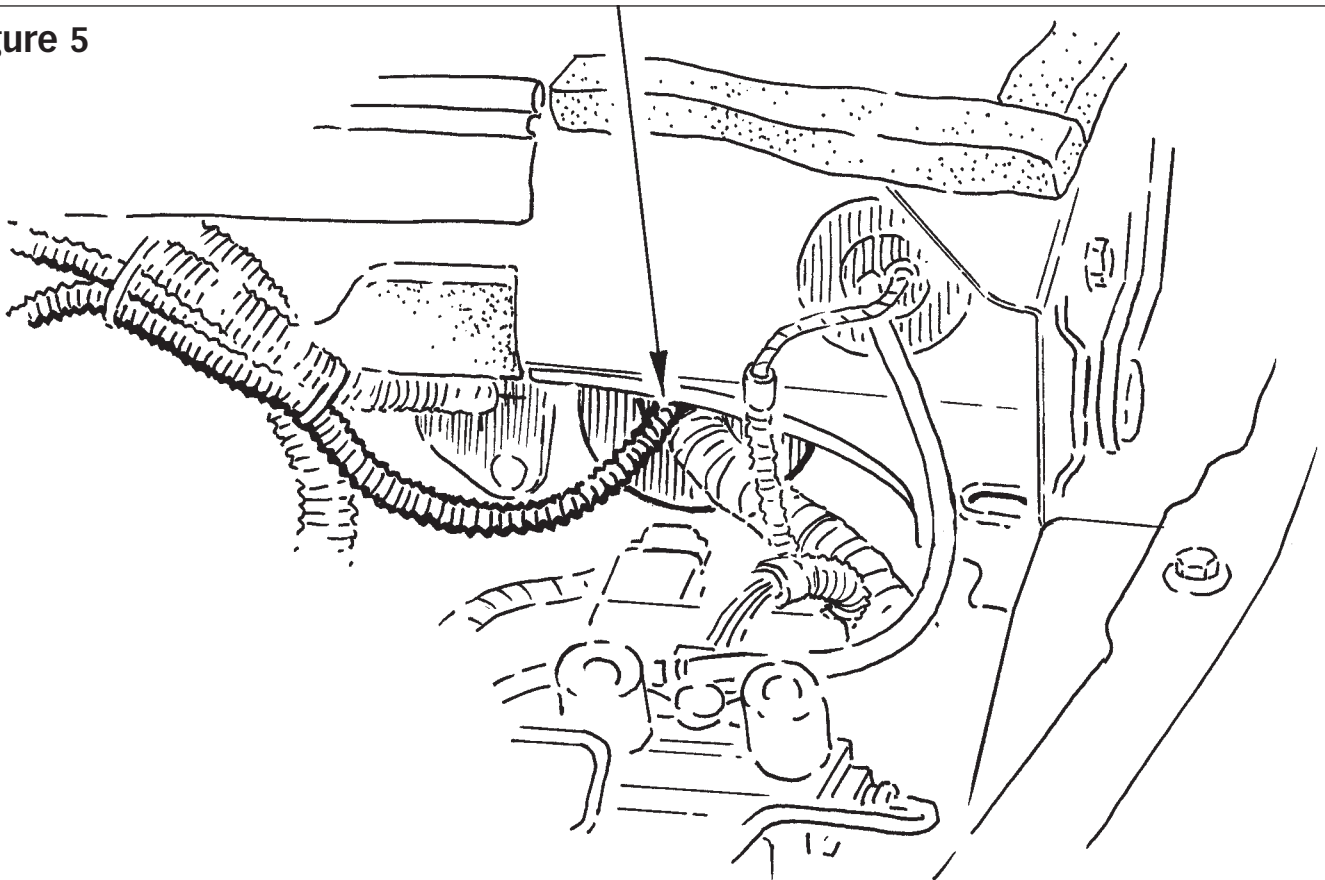

Figure 6

CUT WHITE WIRE WITH A PINK TRACER, THEN INSTALL CRIMP-ON MALE AND FEMALE SPADE CONNECTORS. PLUG BROWN WIRES FROM BANKS WIRING HARNESS INTO SPADE CONNECTORS.

THESE CONNECTORS MAY NOT BE LOCATED ON THE FIREWALL OR IN THIS RELATIONSHIP TO EACH OTHER IN SOME VEHICLES.

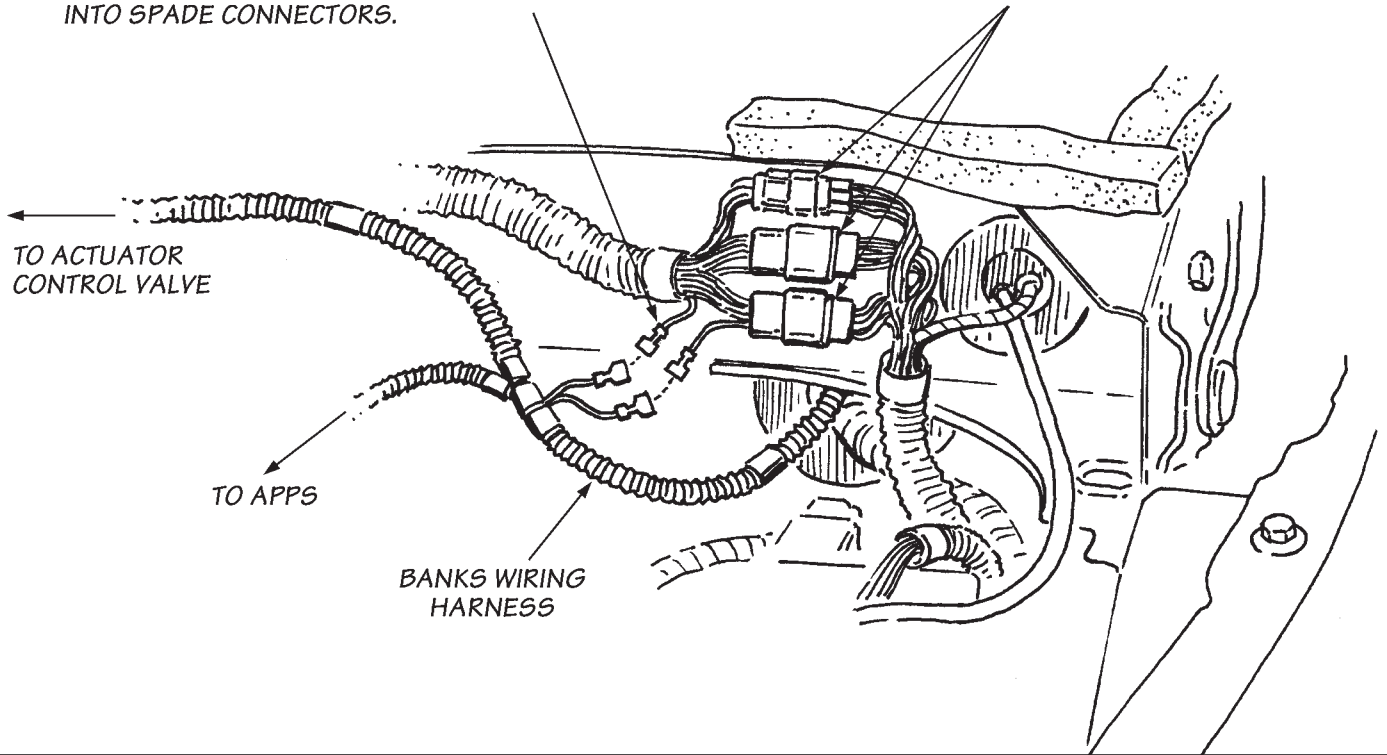

Figure 7

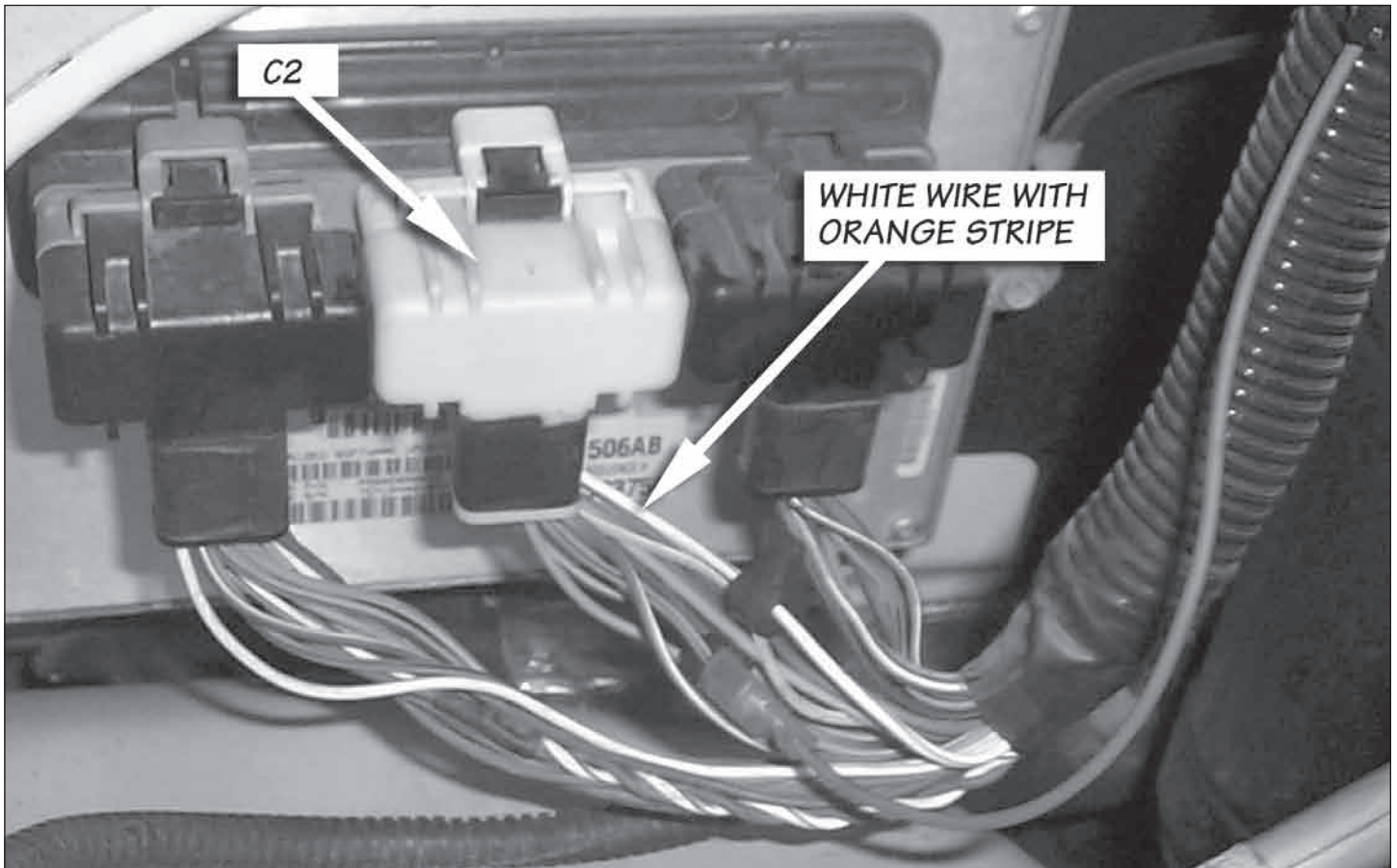
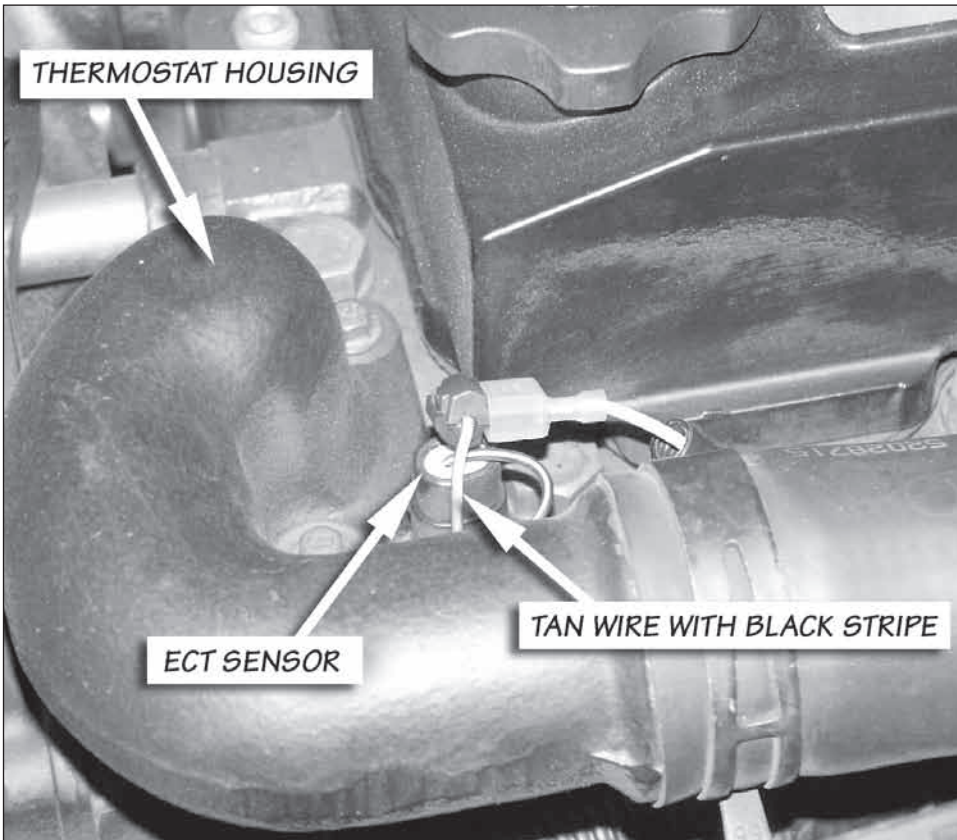

Figure 8



14. Drill a 1/8" pilot hole and mount the actuator control valve to the upper passenger side firewall as shown in **Figure 4** using the #12 self-threading screw provided.

15. On the driver's side firewall, there is a large, soft 3 1/2"-diameter grommet located under the cowl that allows the vehicle's wiring harness to pass from the cab to the engine compartment. Enlarge the hole approximately 1/2" to allow the Banks Brake wiring harness to pass through. Be careful not to damage the vehicle harness. See **Figure 5**.

16. Inside the cab, remove the dash kick panel below the steering column by removing the three screws and pulling on the panel.

17. Starting with the orange and gray wires, feed the Banks Brake harness through the hole located in Step 15. Continue to feed the harness through until the convolute with the blue wire is through the firewall. **For vehicles with automatic transmissions proceed to Step 19.**

18. If your vehicle is a manual transmission and equipped with cruise control, continue to feed the harness through until the convolute containing two brown wires (taped to the harness) are through the firewall. Locate and cut the white wire with a pink tracer located in the vehicle harness bundle shown in **Figure 6**.

Figure 9

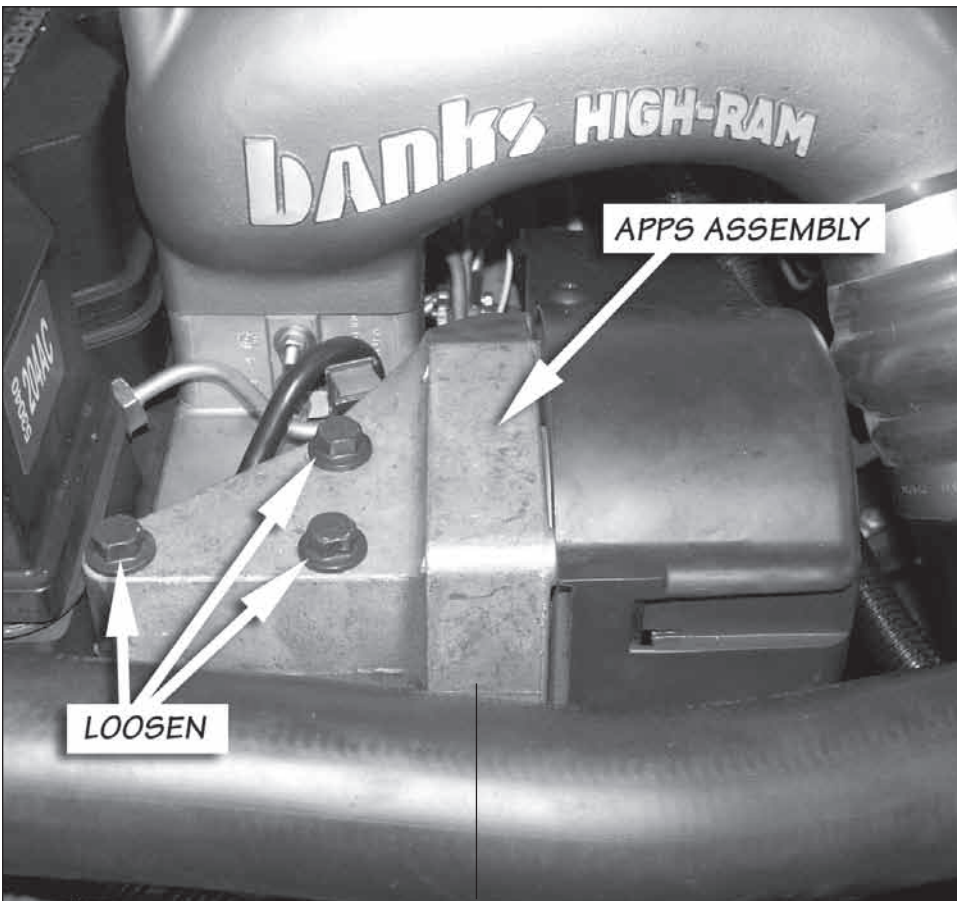

Figure 10

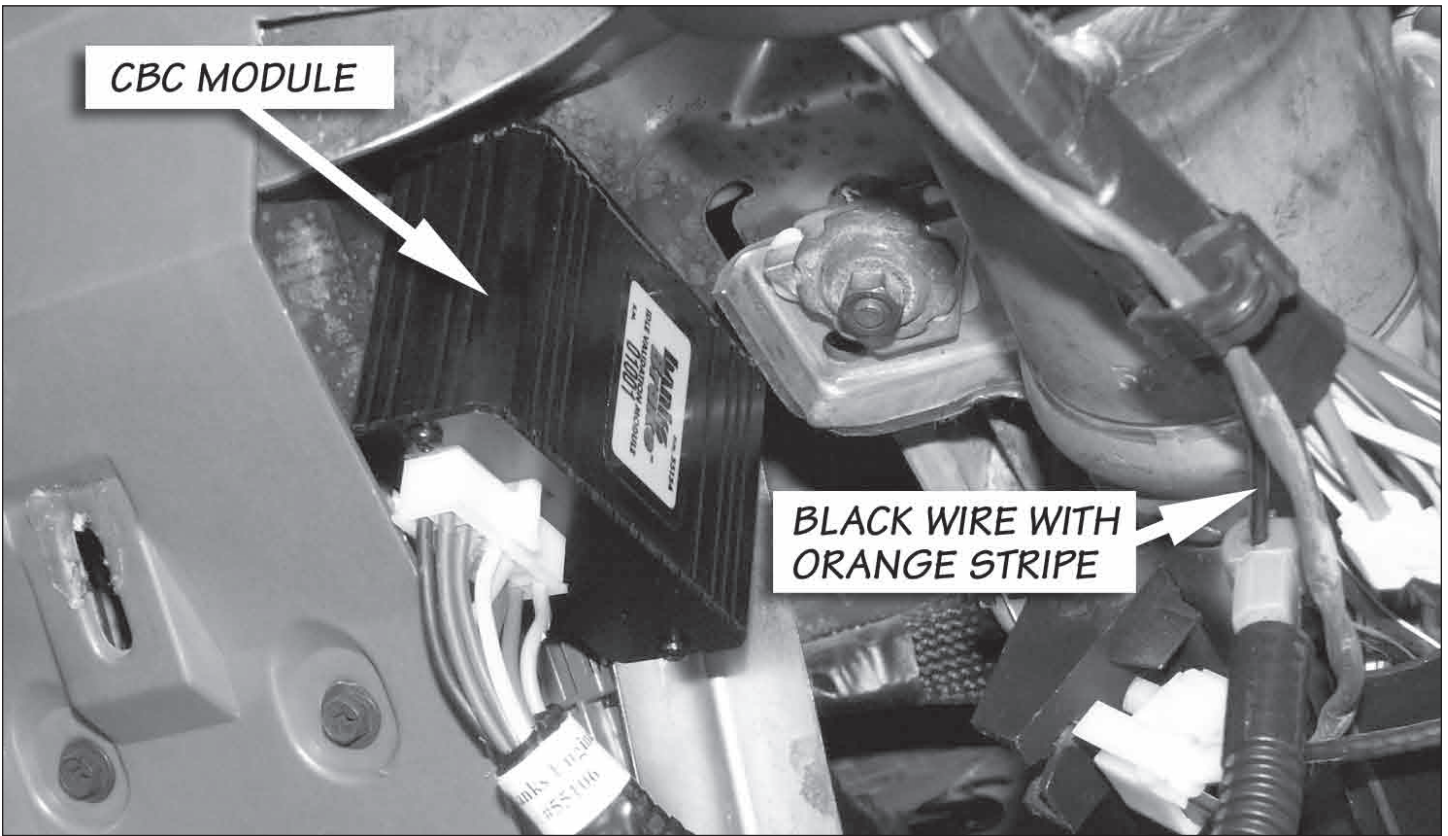

Figure 11

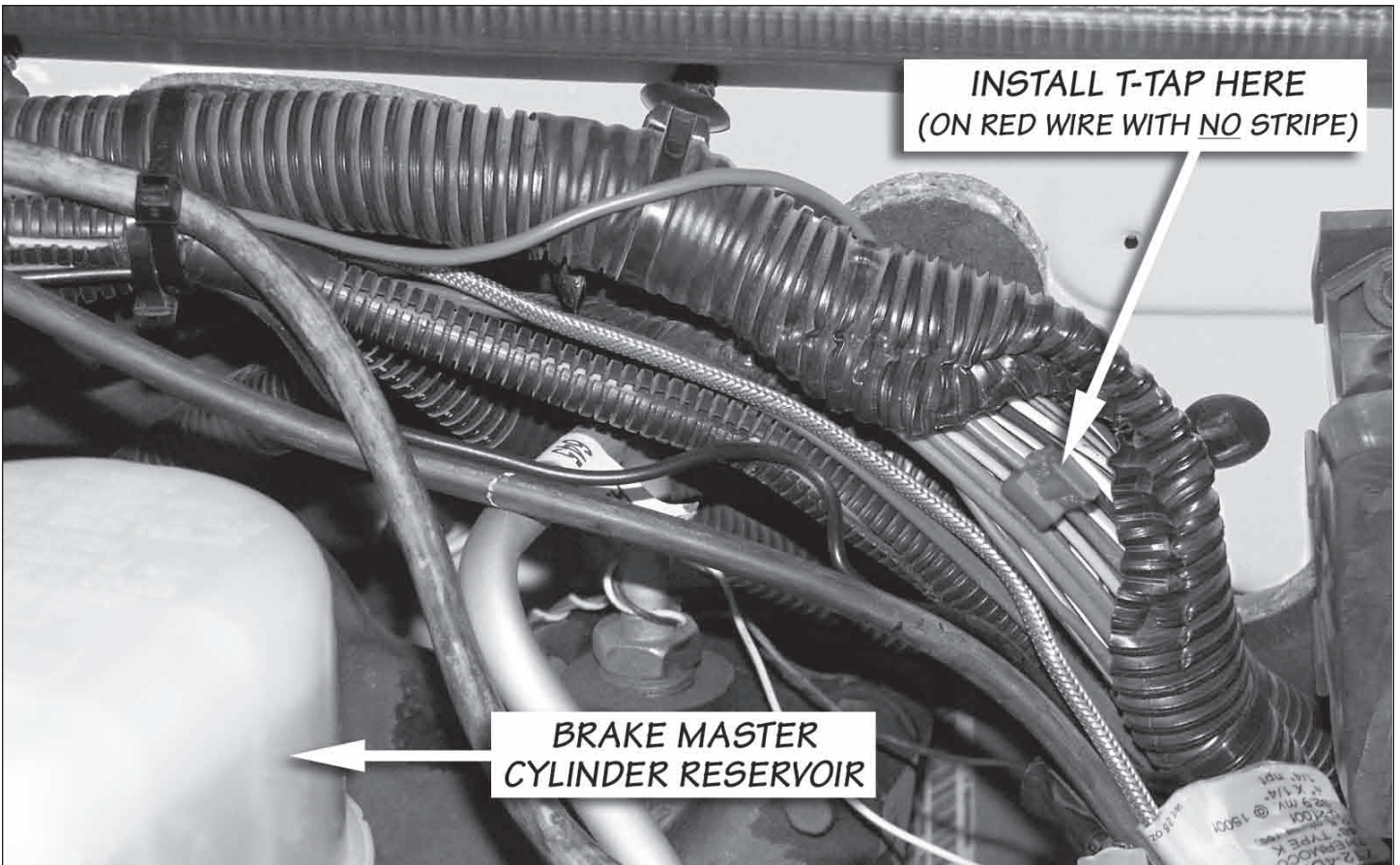
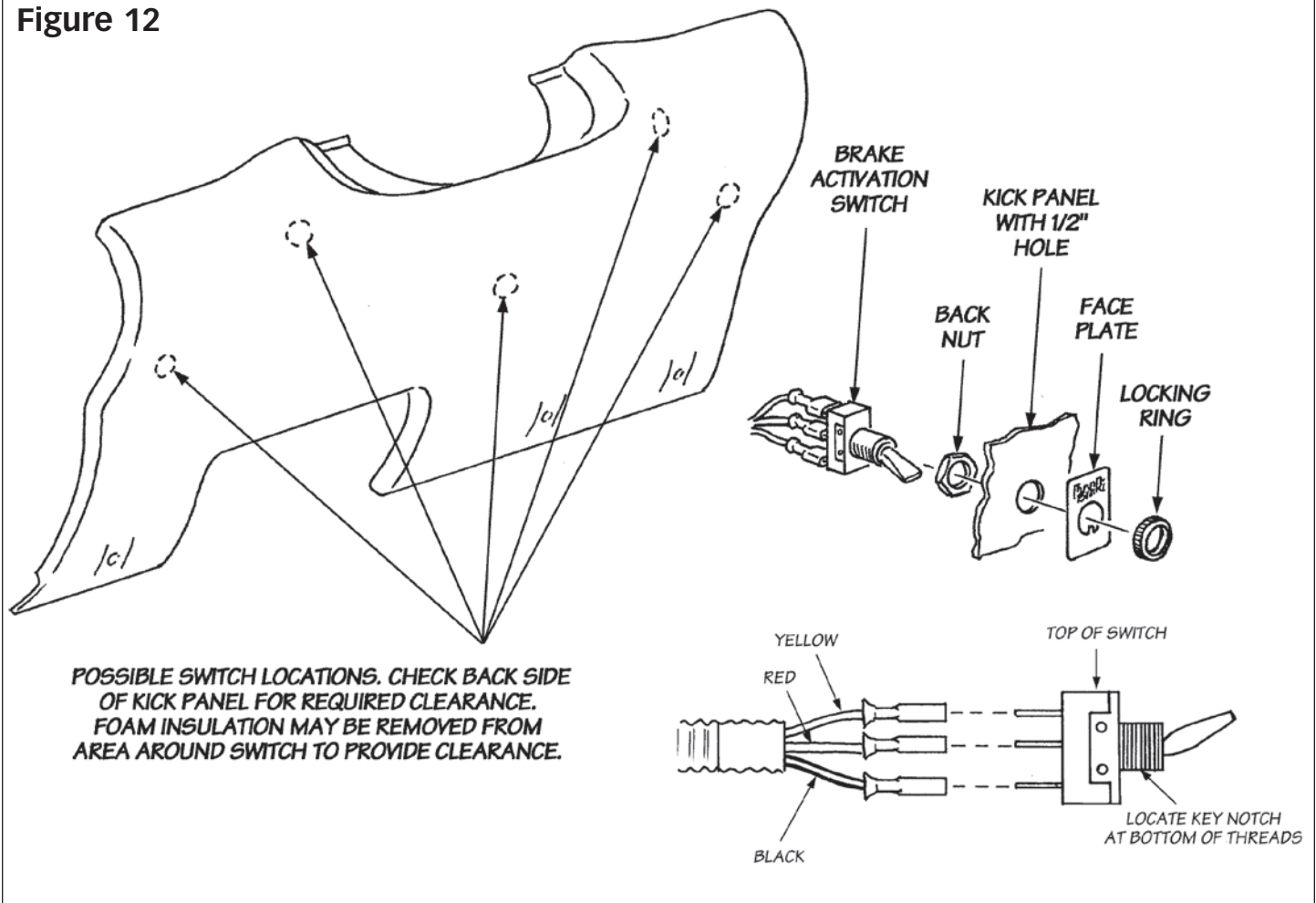

Figure 12



Note: Be sure to cut the correct color wire. There may be a white wire with a red tracer in close proximity to the cruise control wire and may easily be mistaken for the right lead. Crimp the male and female 1/4" spade connectors to each end of the cut wires. Connect the two brown wires from the harness to feed spade connector.

19. Route the orange wire along the underside of the cowl lip towards the PCM.

20. Locate the white wire with orange stripe from pin 27 at connector C2 (middle connector). Install a supplied red T-tap onto the wire. See **Figure 7**.

21. Plug the connector on the end of the orange wire from the Banks Brake harness into the red T-tap installed in Step **20**.

22. Plug the connectors on the green and black wires from the Banks Brake harness into the connectors on the black solenoid valve leads.

23. Route the gray wire from the Banks Brake harness towards the front of the engine.

24. Locate the tan wire with black stripe at the Engine Coolant Temperature (ECT) sensor. Install a supplied red T-tap onto the wire. See **Figure 8**.

25. Plug the connector on the end of the gray wire from the Banks Brake harness into the red T-tap installed in Step **24**.

26. Remove the accelerator pedal position sensor assembly (APPS) by loosening the three bolts as shown in **Figure 9**.

27. Locate the light blue wire with black stripe running into the APPS connector under the APPS assembly. Install a supplied red T-tap onto the wire approximately two inches from the APPS assembly. The wire may be covered by convolute from the factory. If so, peel the factory convolute away from the wire to allow for installation of the red T-tap.

Figure 13

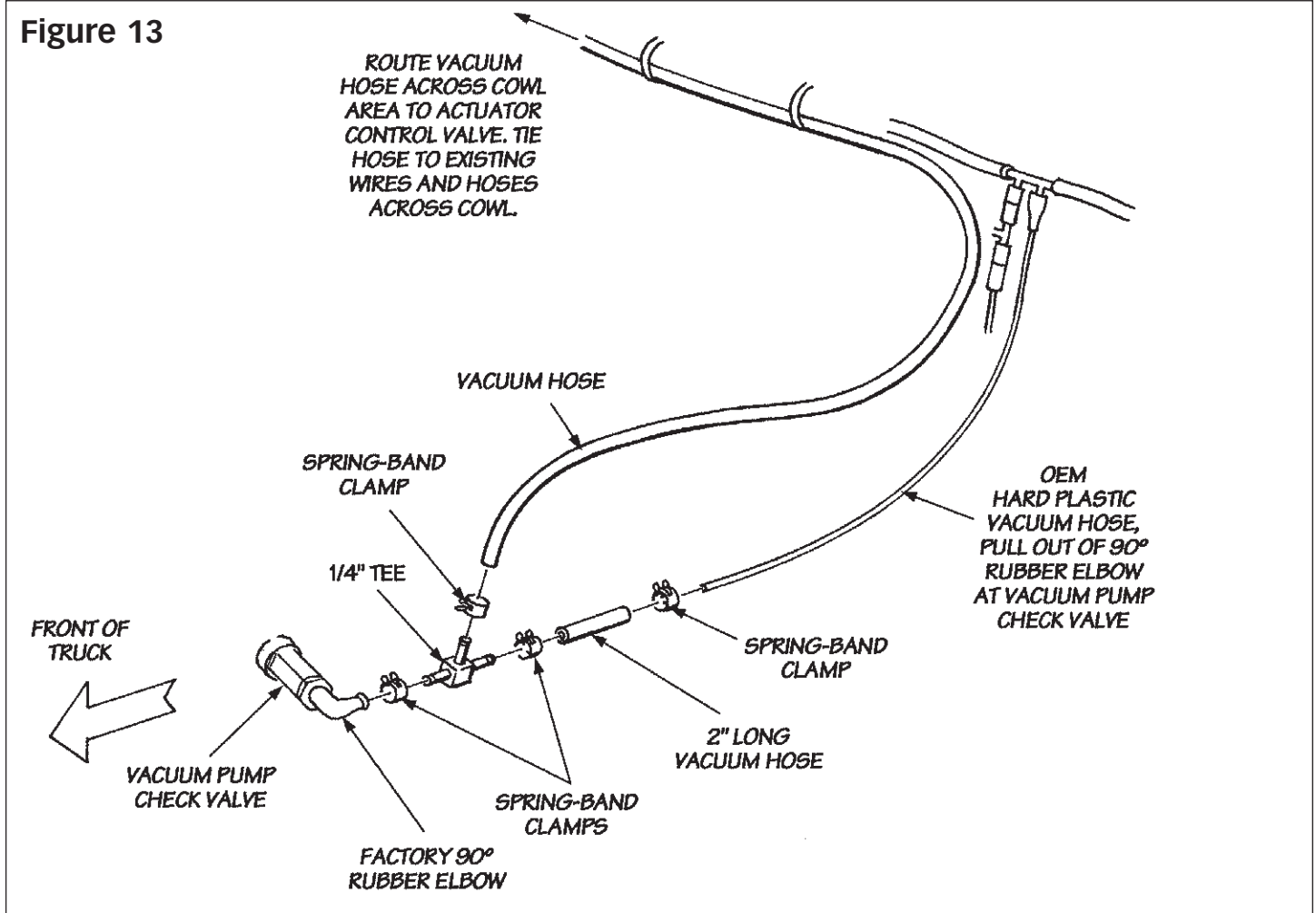

28. Plug the connector on the end of the blue wire from the Banks Brake harness into the red T-tap installed in Step 27.

29. Reinstall the APPS assembly. Tighten the three bolts to 105 in-lbs. (not ft-lbs)

30. Find a suitable mounting location for the CBC module. Banks recommends mounting the CBC module in the location shown in Figure 10. Ensure that the mounting surface is clean and free of any oil, grease, or dirt. Clean and dry as required using a cloth and rubbing alcohol or similar solution.

31. Peel the protective backing from the foam tape on the CBC module and mount the CBC module as shown in Figure 10. The CBC module should be oriented with the connector facing down. Apply light pressure to the CBC module by hand for 60 seconds to seat the foam tape and create a strong bond.

32. Using a factory screw, attach the ring terminal on the end of the black wire from the 14-pin connector on the Banks Brake harness to the metal dash supports (suitable chassis ground). If a suitable factory screw cannot be located, use the supplied self-tapping screw.

33. Plug the 14-pin connector on the Banks Brake harness into the CBC module.

34. Install the supplied 2-amp fuse into the fuse holder on the Banks Brake harness.

35. On 1998-2002 vehicles equipped with manual transmissions AND 1998 vehicles equipped with automatic transmission: Install a blue T-tap on the 14 AWG black wire with an orange tracer located in the harness running from the steering column. Attach the black fused power lead as shown in Figure 10.

Figure 14

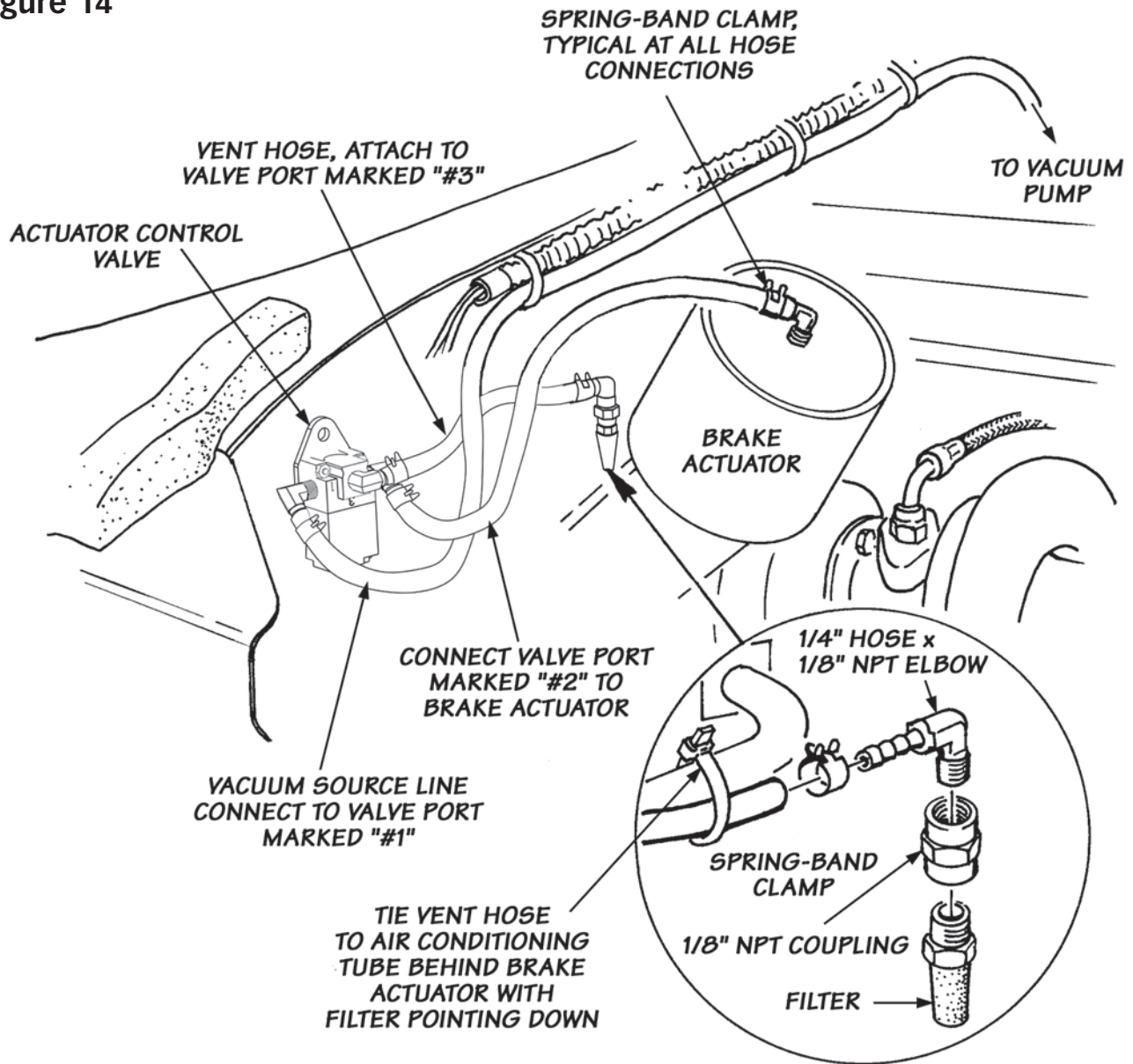

On 1999-2002 vehicles equipped with automatic transmissions: Plug the supplied wire extension into the end of the fused power lead. Route the wire extension through the firewall following the previously installed Banks wiring. Install the supplied blue T-tap on the red wire located in the wiring harness in the engine compartment as shown in **Figure 11**. Plug the remaining end of the Banks wire extension into the blue T-tap.

36. Find an appropriate location for the brake activation switch on the lower dash panel. See **Figure 12** for suggested locations. Drill a $\frac{1}{2}$ " hole through the dash panel at this location. Note that the backside layer of reinforcing material may need to be removed in the area used to mount the activation switch.

37. Attach the three wiring harness leads to the switch assembly per **Figure 12**. Remove the outer locking ring from the shaft of the switch assembly and install the switch from the back side of the dash panel with the notch in the shaft facing down. Slide the face plate provided over the shaft of the switch to indicate switch position. Thread the locking ring onto the shaft of the switch body. The depth of the switch may be changed by adjusting the location of the back nut on the switch shaft.

38. Secure the wire loom under the dash and hood using the nylon ties provided.

39. Attach the remaining ring terminal to the metal dash supports (suitable chassis ground) using a factory screw.

40. Find the OEM hose running from the vacuum pump/check valve just forward of the vehicle power steering pump. Disconnect the 90 degree elbow and install the brass T-fitting as shown in **Figure 13**.

41. Cut a short length of blue silicone hose (approximately 2") and push it on to the plastic nipple at the end of the factory hard plastic vacuum tube. Attach the other end of the short silicone hose to the T-fitting.

42. Re-attach the factory 90-degree elbow to the outlet of the vacuum pump/check valve. Secure all connections with supplied spring band clamps.

43. Use the remaining length of blue silicone hose to connect the vacuum supply to the actuator control valve and actuator. Run a length of hose from the brass $\frac{1}{4}$ " T-fitting up to the factory vacuum manifold on the firewall and across the cowl area to the previously installed actuator control valve.

44. Attach the vacuum source line to the port on the valve labeled #1. From the port labeled #2, run a length of blue silicone hose to the exhaust brake actuator. See **Figure 14**.

45. Assemble the black vent hose as shown and attach this line to the port labeled #3. Run this line behind the exhaust brake assembly and secure to a convenient location. Be sure the bronze filter is facing down so any collected moisture will be drained. Secure all vacuum lines with spring band clamps as shown. See **Figure 14**.

46. Secure all vacuum lines under the hood using the nylon ties provided. Use care to avoid pinching the hose closed.

Functional Testing

*NOTE: The following testing should be performed only after the vehicle has been allowed to **COMPLETELY COOL**. This test verifies the performance of the warm-up feature of the brake system and must be performed with a cold vehicle.*

47. Verify that the Banks Brake Activation Switch is in the "OFF" position.

48. Ensure that the accelerator pedal is **NOT** depressed. Turn the ignition key to the "ON" position. The **green LED** on the Computerized Brake Controller (CBC) should light up.

49. Slowly press the accelerator pedal. The **green LED** should turn off almost immediately (very little throttle movement). Release the accelerator pedal and the **green LED** should again light up. Repeat this cycle a few times to verify CBC function.

50. Start the engine and let it idle. The brake valve will close and can be verified by the muffled sound of a restricted exhaust pipe.

51. Slowly press the accelerator pedal. The **green LED** should turn off almost immediately (very little throttle movement) and the solenoid valve assembly should vent the air from the brake actuator and the brake valve should open. Release the accelerator pedal and the **green LED** should again light up. Repeat this cycle a few times to verify CBC function.

NOTE: The engine speed (RPM) should not exceed 1200 rpm prior to brake disengagement.

52. Allow the vehicle to reach normal operating temperature. The brake will remain active until the vehicle reaches approximately 125°F engine coolant temperature. Once the vehicle warms up, the brake will turn off.

53. Re-install the lower dash panel.

NOTE: Once the vehicle has passed the initial functional tests outlined in Steps 47-53 the vehicle can be driven in order to complete the required functional testing.

54. Obtain a vehicle speed of approximately 40-45 mph in an area where speeds of this nature are safe and traffic is light. Turn the Banks Brake activation switch to the **"ON"** position. Release the throttle. The brake should activate and the vehicle will begin to slow. Bring the vehicle to a safe stop (using the service brakes). As the vehicle speed drops below approximately 15 mph the brake should turn off. Turn the Banks Brake activation switch to the **"OFF"** position.

NOTE: The vehicle must be traveling above 30 mph for the brake to activate. Once activated, the brake will remain on until the vehicle slows to less than 15 mph or the throttle is depressed.

NOTE: Once the vehicle has passed the test outlined in Step 54, the installation of the Banks Brake system is complete and ready for years of reliable service.

Trouble Shooting

If the Banks Brake does not pass the **FUNCTIONAL TESTING** or ceases to function, re-check all connections per the installation instructions. Test for the following voltages at the CBC connector:

1st, test the following with the engine cold and the

KEY ON and ENGINE OFF:

- BLUE wire 0.4 - 1.0V
- GRAY wire 4 - 5V

2nd, test the following with the

KEY ON and ENGINE RUNNING:

- YELLOW wire 12V

If any of these voltages are not present, trace the corresponding wire to the connections at either ends and re-check the connections. If all voltages are present, repeat **FUNCTIONAL TESTING**. The **green LED** should be lit, indicating the Brake should now function as described.

If **green LED** does not light or compressor does not run, call Banks Installation Support for assistance.

Safety

Caution: Your Banks Brake is NOT a substitute for the hydraulic brakes on your truck. The device will not correct or compensate for improperly maintained hydraulic brakes. Also please be aware that your Banks Brake is not designed to be used as a parking brake or to bring your vehicle to a complete stop. Your Banks Brake is a supplementary braking system designed to help you slow down or to assist you in maintaining a more constant speed when descending a grade. Remember that this exhaust brake is first and foremost a safety device and it is most efficient when used to prevent, rather than correct a runaway vehicle condition.

The use of a Banks Brake does not increase the load capacity of your vehicle. Gross Combined Weight Rating specifications should always be adhered to. The Banks Brake will allow you to slow your vehicle more effectively within your vehicle's weight specifications.

Operation/ Driving Tips

Use your Banks Brake to assist in slowing your vehicle while traveling down grades. To activate the brake, flip the switch to the "ON" position. With the switch on, the brake will be active anytime the accelerator pedal is not depressed.

When alternating between braking activity and acceleration, it is a good practice to allow a minimum of one second to elapse after the brake has been disabled or the throttle is applied before reaching full throttle acceleration. This allows enough time for the brake valve to fully open and eliminates the possibility of excess exhaust back pressure being introduced into the engine.

If your vehicle is equipped with an Automatic transmission, your Banks Brake can be used with the transmission in overdrive or 3rd gear.

To increase the overall effectiveness of the Banks Brake you may back shift from overdrive to 3rd thereby increasing engine rpm. (Brake performance will be optimal at 2000 rpm or higher.) Back shifting to 2nd gear with the Brake activated is not recommended due to the fact that the torque converter is unlocked in 2nd and could result in increased transmission temperatures.

If your vehicle is equipped with a manual transmission you can also down shift to maintain peak retarding force.

Maintenance

When the engine is cold (below 125°F) the exhaust brake will activate to reduce the amount of warm-up time required. Once the vehicle reaches operating temperature the brake will open. This cold start brake activation also serves as a maintenance cycle, which helps prevent soot build-up and keeps the shaft assembly from sticking. This process is automated and eliminates the need for any additional maintenance.

If it becomes necessary to remove the CBC from the vehicle, a by-pass plug has been provided to install in its place. The CBC should only be removed when the ignition switch is in the "OFF" position.

Banks Brake, General Assembly

ITEM #	PART #	DESCRIPTION	QTY
1	55020	Exhaust Brake Assembly	1
2	55106	Wire Harness	1
3	62062	Fuse, 2A	1
4	55196	Turbine Outlet Pipe	1
5	55133	Actuator Control Valve	1
6	55117	Valve Bracket	1
7	55170	Valve Filter	1
8	62002	Nylon Ties	15
9	62032	Blue T-tap	2
10	62130	Switch	1
11	62131	Cover Plate	1
12	91201	5/16" AN Washer	5
13	91602	7/16" SAE Washer	2
14	91622	7/16-14 x 2" Stainless Bolt	2
15	91813	8mm x 25mm Long Bolt	4
16	91814	8mm x 40mm Long Bolt	1
17	91862	4-40 Nylock Nut	2
18	91852	#12 x 3/4" Long Sheet Metal Screw	2
19	91861	4-40 Screw x .875" Long	2
20	91863	#4 SAE Washers	2
21	92121	Fitting 90° 1/8" NPT x 3/16" Hose Barb	4
22	92243	T-Fitting 1/4" Hose Barb	1
23	55166	CBC (Computerized Brake Controller)	1
24	92875	Spring Band Clamp	9
25	94121	Silicone Hose, Blue	7
26	52470	Exhaust Clamp	1

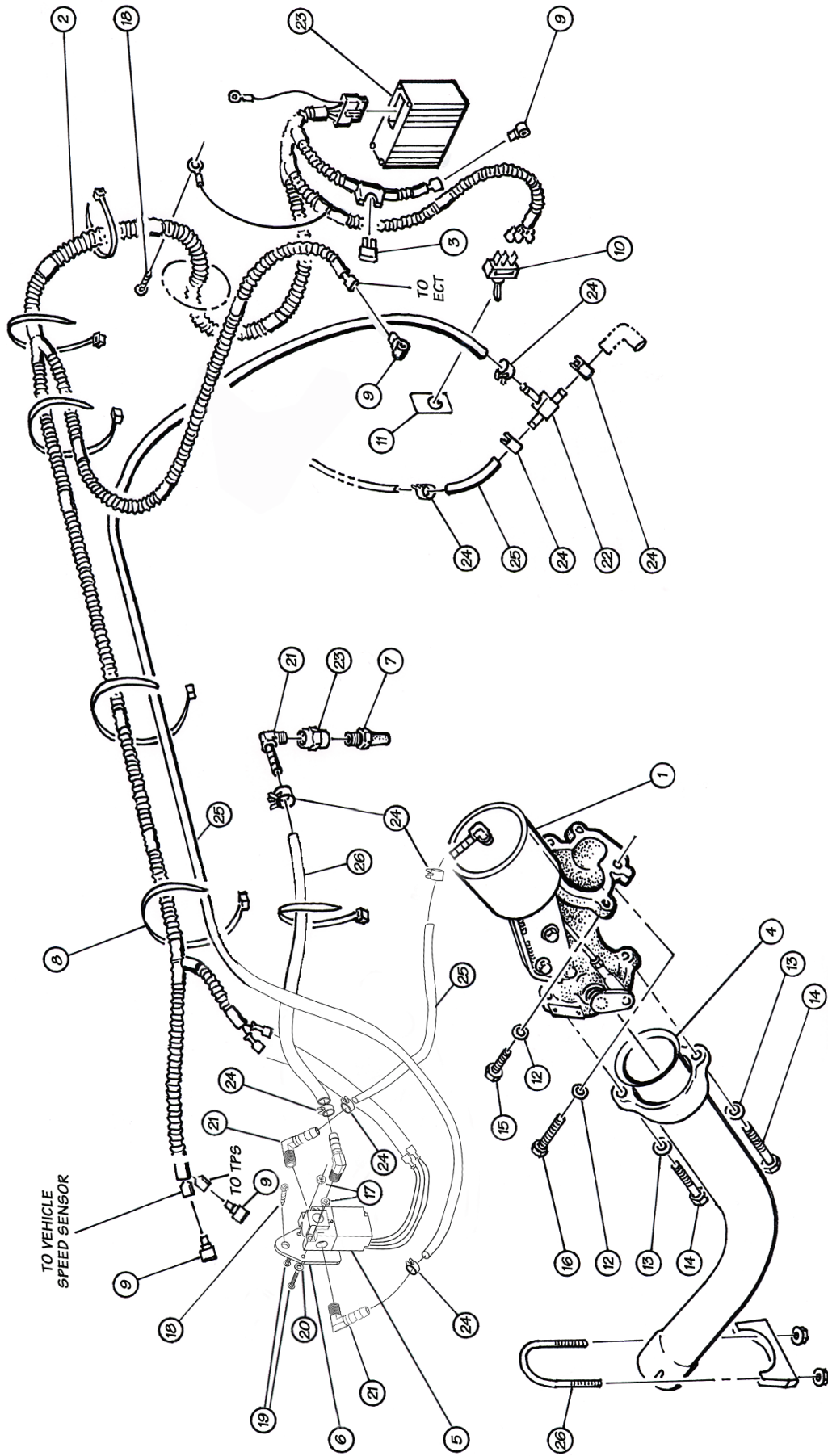

Gale Banks Engineering
546 Duggan Avenue • Azusa, CA 91702
(626) 969-9600 • Fax (626) 334-1743

Product Information & Sales: (800) 438-7693

bankspower.com