

with Installation Instructions

Owner's Manual

Banks Six-Gun® & Banks Brake®

*For use with Six-Gun® Power Tuner, with
Six-Gun Switch only*

2008-2010 Ford Power Stroke 6.4L Turbo-Diesel

THIS MANUAL IS FOR USE WITH SYSTEMS 63907, 55469

Gale Banks Engineering
546 Duggan Avenue • Azusa, CA 91702
(626) 969-9600 • Fax (626) 334-1743

Product Information & Sales: (888) 635-4565

bankspower.com



Also Available from Banks Power

08-10 Ford 6.4L

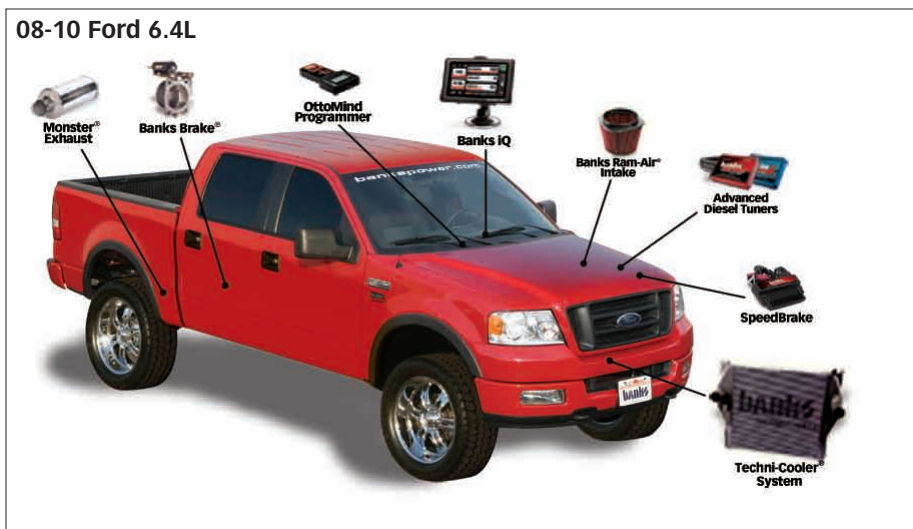

Banks iQ System (P/N 61155)

- 5" touchscreen interface that can control the Banks Diesel Tuner and/or SpeedBrake on the fly.
- Interchangable gauge display, read and clear codes, monitor engine diagnostics, log data, time your vehicles runs and much more.

Banks Monster® Exhaust System (Single and Dual P/N 49780-49787)

- Increases exhaust flow, cuts backpressure, lowers exhaust gas temperatures (EGTs) and increases power.

Banks Ram-Air Intake System (P/N 42185)

- Increases your airflow over stock.
- Adds power, improves fuel economy, lowers EGTs and reduces smoke.

Banks Techni-Cooler® System (P/N 25984)

- Provides increased air flow to the engine by increasing air density for more increased power, lower EGTs and improved fuel economy.

Banks Exhaust Brake (P/N 55469)

- Increases the stopping power of your truck and extends the service life of your brakes

Banks SpeedBrake (P/N 55464)

- Allows for controlled hill decent at a user defined vehicle speed.

Banks Diesel Tuner Six-Gun (P/N 63907)

- Adds power safely to your vehicle
- Engine and transmission safeguards
- Change power levels on-the-fly

**For More Information please call (888) 635-4565
or Visit us online @ www.bankspower.com**

**OttoMind Programmer
(P/N 66063)**

- Contains Banks tunes that boost your vehicles HP, Torque and MPG.
- Displays a host of critical engine functions
- Provides "service technician" diagnostic capabilities
- Has upgradeable functionality, so it will never be out of date

**Six-Gun Bundle
(P/N 46652-46655)**

Contains:

- Monster Exhaust (single and dual)
- Ram-Air Intake
- Six-Gun Tuner w/ Banks iQ

**Big Boss Bundle
(P/N 46656-46659)**

Contains:

- Monster Exhaust (single and dual)
- Ram-Air Intake
- Six-Gun Tuner w/ Banks iQ
- Techni-Cooler

Do not use this product until you have carefully read the following agreement.

This sets forth the terms and conditions for the use of this product. The installation of this product indicates that the BUYER has read and understands this agreement and accepts its terms and conditions.

Disclaimer of Liability

Gale Banks Engineering Inc., and its distributors, employees, and dealers (hereafter "SELLER") shall in no way be responsible for the product's proper use and service. The BUYER hereby waives all liability claims.

The BUYER acknowledges that he/she is not relying on the SELLER's skill or judgement to select or furnish goods suitable for any particular purpose and that there are no liabilities which extended beyond the description on the face hereof and the BUYER hereby waives all remedies or liabilities, expressed or implied, arising by law or otherwise, (including without any obligations of the SELLER with respect to fitness, merchantability, and consequential damages) whether or not occasioned by the SELLER's negligence.

The BUYER is responsible to fully understand the capability and limitations of his/her vehicle according to manufacturer specifications and agrees to hold the SELLER harmless from any damage resulting from the failure to adhere to such specifications.

The SELLER disclaims any warranty and expressly disclaims any liability for personal injury or damages. The BUYER acknowledges and agrees that the disclaimer of any liability for

personal injury is a material term for this agreement and the BUYER agrees to indemnify the SELLER and to hold the SELLER harmless from any claim related to the item of the equipment purchased. Under no circumstances will the SELLER be liable for any damages or expenses by reason of the use or sale of any such equipment.

The BUYER is responsible to obey all applicable federal, state, and local laws, statutes, and ordinances when operating his/her vehicle, and the BUYER agrees to hold the SELLER harmless from any violation thereof.

The SELLER assumes no liability regarding the improper installation or misapplication of its products. It is the installer's responsibility to check for proper installation and if in doubt, contact the manufacturer.

The BUYER is solely responsible for all warranty issues from the automotive manufacturer.

Limitation of Warranty

Gale Banks Engineering Inc. (hereafter "SELLER"), gives Limited Warranty as to description, quality, merchantability, fitness for any particular purpose, productiveness, or any other matter of SELLER's product sold herewith. The SELLER shall be in no way responsible for the product's open use and service and the BUYER hereby waives all rights except those expressly written herein. This Warranty shall not be extended or varied except by written instrument signed by SELLER and BUYER.

The Warranty is Limited to two (2) years from the date of sale. All products that are in question of Warranty must be returned shipping prepaid to the SELLER and must be accompanied by a dated proof of purchase receipt. All Warranty claims are subject to approval by Gale Banks Engineering Inc.

Under no circumstance shall the SELLER be liable for any labor charged or travel time incurred in diagnosis for defects, removal, or reinstallation of this product, or any other contingent expense.

Under no circumstances will the SELLER be liable for any damage or expenses incurred by reason of the use or sale of any such equipment.

In the event that the buyer does not agree with this agreement:

The buyer may promptly return this product, in a new and unused condition, with a dated proof-of-purchase, to the place-of-purchase within thirty (30) days from date-of-purchase for a full refund.

The installation of this product indicates that the buyer has read and understands this agreement and accepts its terms and conditions.

Table of Contents

General Installation Practices	6
Section 1	7
Installation of Banks Six-Gun Wire Harness	
Section 2	13
Installation of Optional Banks Brake Wire Harness	
Section 3	18
Installation of Banks Six-Gun & Banks Brake Switch	
Section 4	22
Banks Brake Operation	
Section 5	24
Automatic Transmission Learning	
Section 6	25
Checking Engine Performance	
Section 7	26
Troubleshooting Banks Six-Gun & Brake	
Section 8	30
Clearing Learned Information	
Section 9	30
Removal of the Six-Gun Diesel Tuner	
Section 10	31
Placement of the Banks Power Decals	

General Installation Practices

Dear Customer,

Your new Banks Brake is a uniquely designed braking system with electronic controls, designed to achieve the optimum level of braking from your vehicle's engine.

If you have any questions concerning the installation of your Banks Brake System, please call our Technical Service Hotline at (888) 839-2700 between 7:00am and 5:00pm (PST). If you have any questions relating to shipping or billing, please contact our Customer Service Department at (888) 839-5600.

Thank you.

- 1.** Before starting work, familiarize yourself with the installation procedure by reading all of the instructions.
- 2.** The exploded views provide only general guidance. Refer to each step and section diagram in this manual for proper instruction.
- 3.** Throughout this manual, the left side of the vehicle refers to the driver side, and the right side to the passenger side.
- 4.** Disconnect the negative (ground) cable from the battery (or batteries, if there are two) before beginning work.
- 5.** Route and tie wires and hoses a minimum of 6" away from exhaust heat, moving parts and sharp edges. Clearance of 8" or more is recommended where possible.
- 6.** When raising the vehicle, support it on properly weight-rated safety stands, ramps or a commercial hoist.

Follow the manufacturer's safety precautions. Take care to balance the vehicle to prevent it from slipping or falling. When using ramps, be sure the front wheels are centered squarely on the topsides. When raising the front of the vehicle, put the transmission in park (automatic) or reverse (manual), set the parking brake, and block the rear wheels. When raising the back of the vehicle, be sure the vehicle is on level ground and the front wheels are blocked securely.

CAUTION: Do not use floor jacks to support the vehicle while working under it. Do not raise the vehicle onto concrete blocks, masonry or any other item not intended specifically for this use.

7. During installation, keep the work area clean. Do not allow anything to be dropped into intake, exhaust, or lubrication system components while performing the installation, as foreign objects will cause immediate engine damage upon start-up.

8. Save this Installation Manual as a reference for system maintenance and service.

TOOLS REQUIRED:

- Inch and metric sockets
- Inch and metric combination and open-end wrenches
- Pliers
- Standard and Phillips head screw drivers
- Wire cutters
- Scissors
- Foot-pound torque wrenches

Section 1

INSTALLATION OF BANKS SIX-GUN WIRE HARNESS

Figure 1: Banks Six-Gun and supplied wiring harness

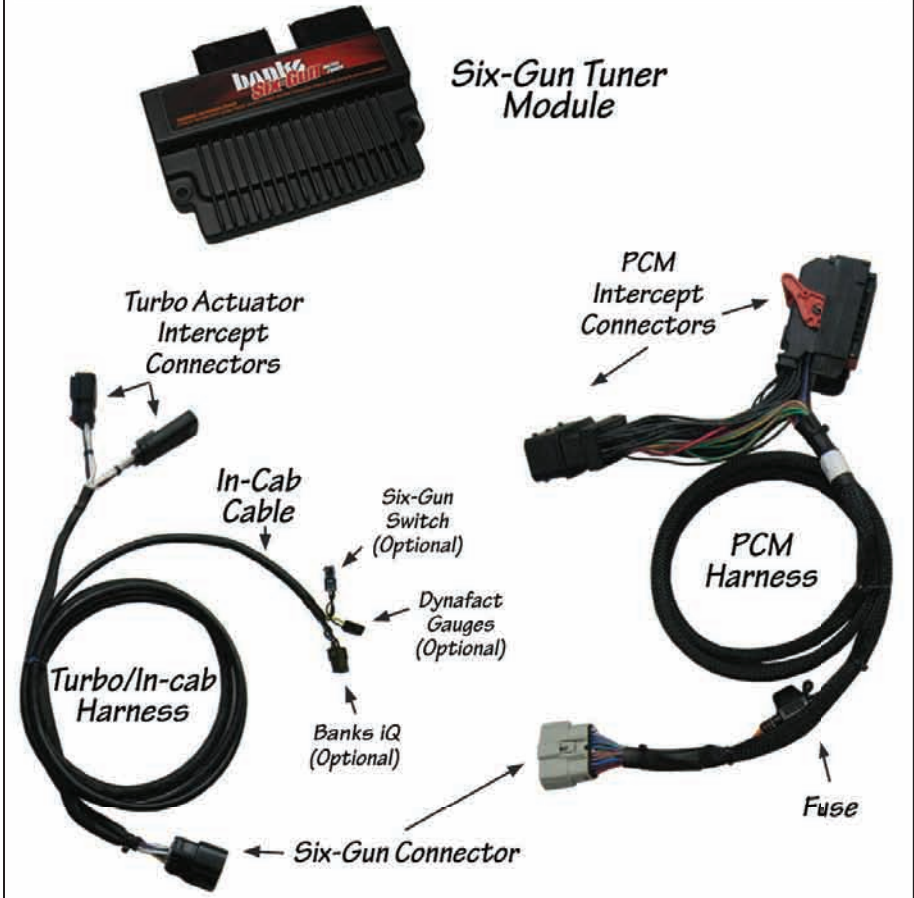

If you have previously installed a Six-Gun and are adding the Banks Brake, Skip to Section 2.

If you are installing the Banks Six-Gun for the first time, continue to Step 1.

Six-Gun Installation

1. Locate the Six-Gun Powertrain Control Module (PCM) Harness. See **Figure 1**. Place harness over the driver side fuse box. Route the PCM connectors from the driver side fuse box along the rail on the rear of the engine compartment to the passenger side of the vehicle. See **Figure 2**.

2. Locate the Factory Powertrain Control Module (PCM) on the passenger side firewall in the engine compartment. See **Figure 2**.

3. Disconnect the left connector from the PCM by opening the locking tab as shown in **Figure 3**.

4. Insert the male connector on the Six Gun Tuner PCM harness into the female connector on the factory harness. Insert the female connector on the Six Gun Tuner PCM harness onto the male connector on the factory PCM. Lock the connection by closing the locking tabs. Secure the connectors behind the oil reservoir and away from any heat source.

5. Secure the Six-Gun Tuner PCM harness along the rail on the firewall with the supplied cable ties.

*NOTE: Do not connect the Six-Gun PCM harness to the tuner. It will be connected in **step 17**.*

6. Locate the Six-Gun Turbo/In-cab harness. Place the harness over the driver side fuse box. Route the turbo actuator connector on the Turbo/in-cab harness along the rail on the rear of the engine compartment to the turbo.

7. Unplug the turbo actuator connector shown in **Figure 4**. The turbo actuator cable connector can be unplugged by sliding the red safety slide down, pressing the locking button, and then pulling on the connector.

8. Plug the female Six-Gun turbo actuator connector into the male factory turbo actuator connector. Plug the female factory turbo actuator connector into the male Six-Gun turbo actuator connector.

9. Secure the Six-Gun turbo actuator connector wires to the firewall rail using the supplied zip ties. Secure the wires away from any heat source.

Figure 2: Six-Gun Harness routing

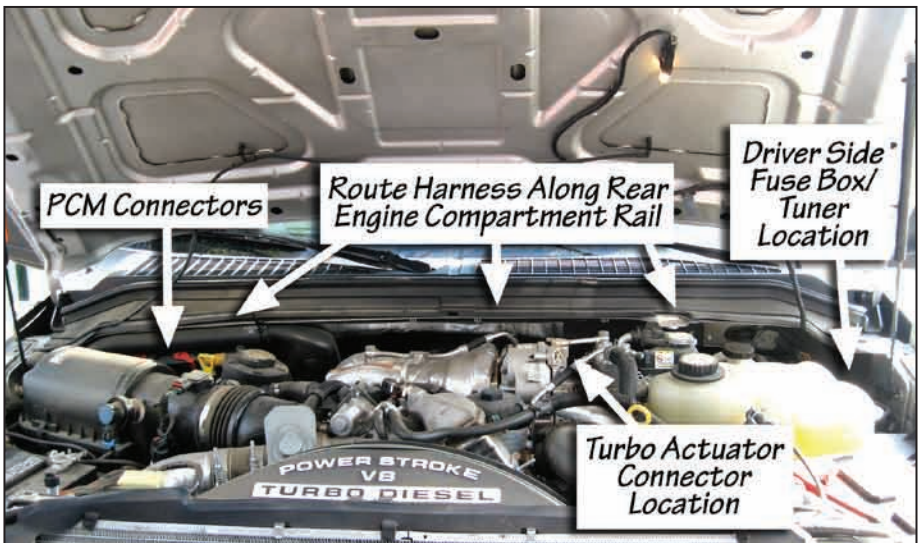

Figure 3: PCM Location on Passenger side.

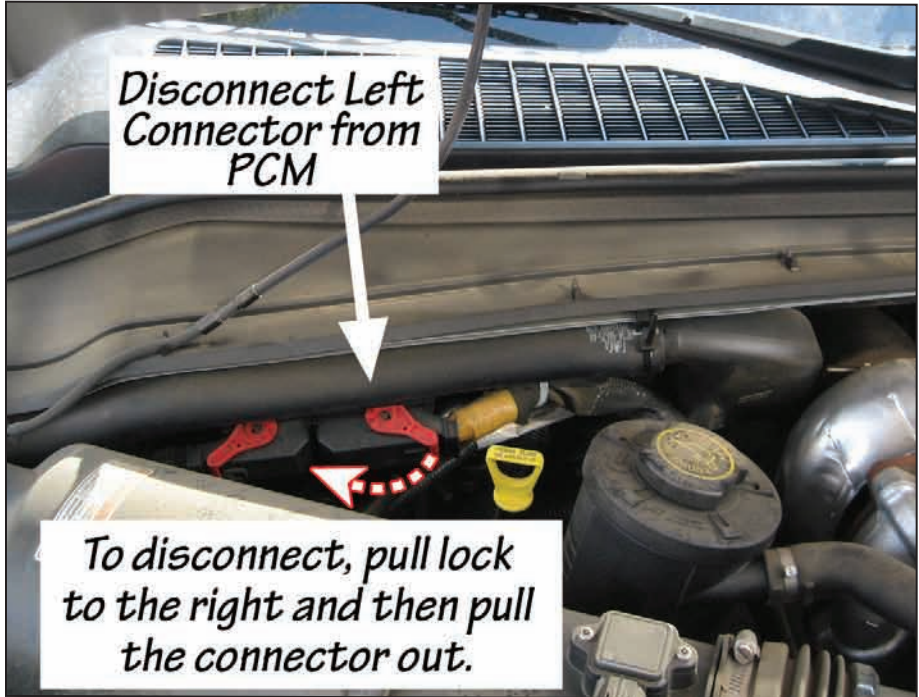
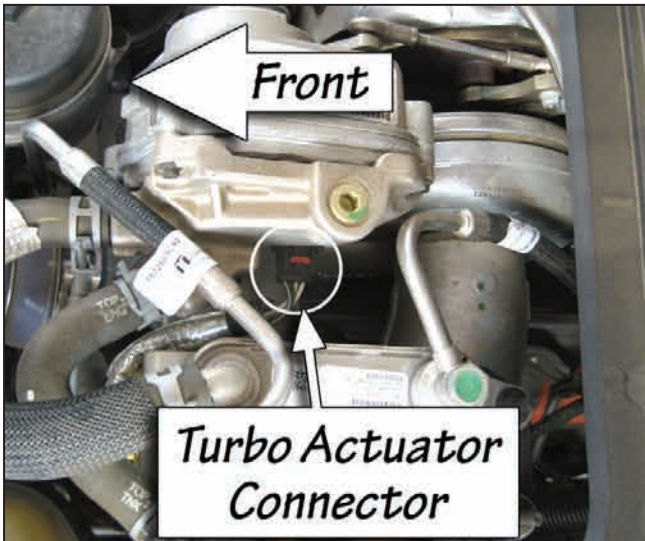

Figure 4: Turbo Actuator Connector



10. Remove the bottom steering column panel by pulling out to release the retaining clip. See **Figure 5**.

Installing harness through firewall.

11. Locate the rubber grommet on the driver's side of the vehicle firewall. The grommet is about 3" in diameter. Make a 1" x 1" cross-shaped (X) incision in the grommet. Be careful so you do not cut the factory harness.

12. From inside the cab locate the grommet on the firewall and make another 1" x 1" cross-shaped (X) incision on the grommet, opposite the spot that was cut from the outside.

Now, feed the Six-Gun In-Cab cable on the Turbo/In-cab harness through the incision made in the firewall grommet and into the cab See **Figure 6**.

NOTE: Some thick putty may be used to provide additional sealing around the In-Cab cable and the grommet. If also installing Banks Brake wait until after Section 2, step 5 to use putty.

Mounting The Six-Gun Diesel Tuner

13. If equipped, remove the vacuum pump from its mounting location by turning the thumb screw and lifting the pump aside. See **Figure 7**.

14. Clean the area on top of the fuse box cover.

NOTE: Make sure the entire mounting surface is clean and free of dirt and oil before mounting the Six-Gun Diesel Tuner. Clean and dry as required using a cloth damped in rubbing alcohol or similar cleaning solution.

Figure 5 Ford (08-09)

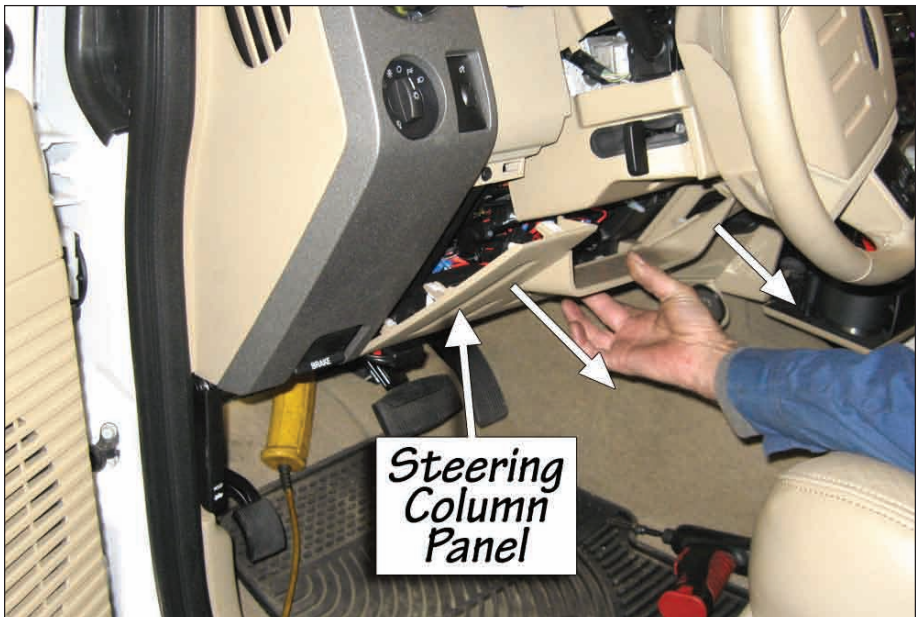
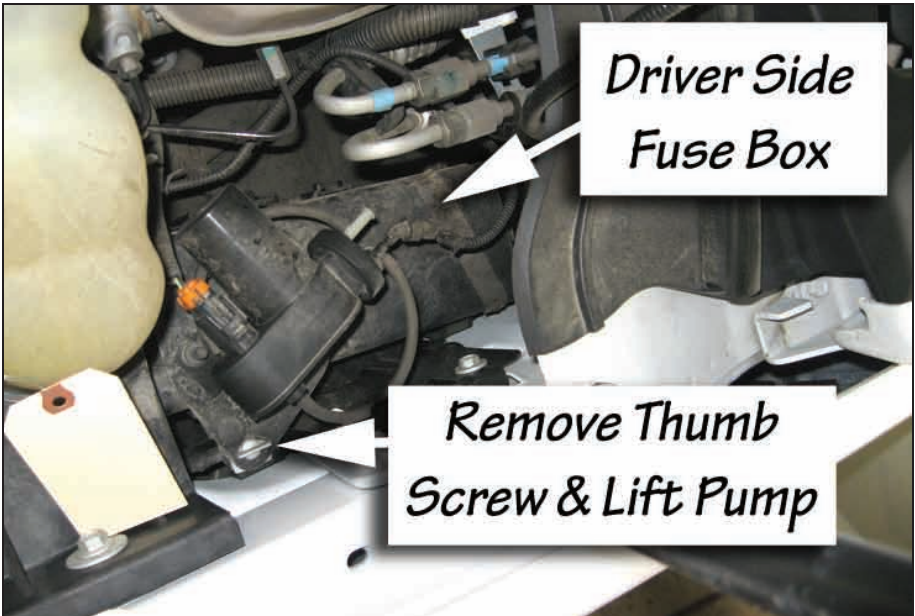

Figure 6: Rubber Grommet on driver side Fire wall



Figure 7



15. Locate the two (2) dual-lock fasteners in your kit. Peel the protective backing off from one side of the hook and loop interlocking fasteners and attach to the recess area on the back of the tuner module.

16. Peel the protective backing off the other side of the hook and loop interlocking fasteners on the back of the tuner module and affix the tuner to the top of the fuse box cover as shown in **Figure 8**. Apply light pressure to the Six-Gun Diesel Tuner module by hand for 60 seconds to create a strong bond between the fuse box and hook & loop interlocking fasteners.

17. Connect the PCM and Turbo/ In-Cab harness connectors to the correct Six-Gun module connection. The connections are keyed differently so make sure to connect the correct one into the appropriate connection. See **Figure 8**.

18. If previously removed, reinstall the Vacuum Pump in place and secure with the factory thumb screw.

19. Go over all connections. Check all connections under the hood and keep wires away from heat sources when possible.

END, SECTION 1-

Figure 8 Mounting location of Six-Gun tuner to Fuse box, driver

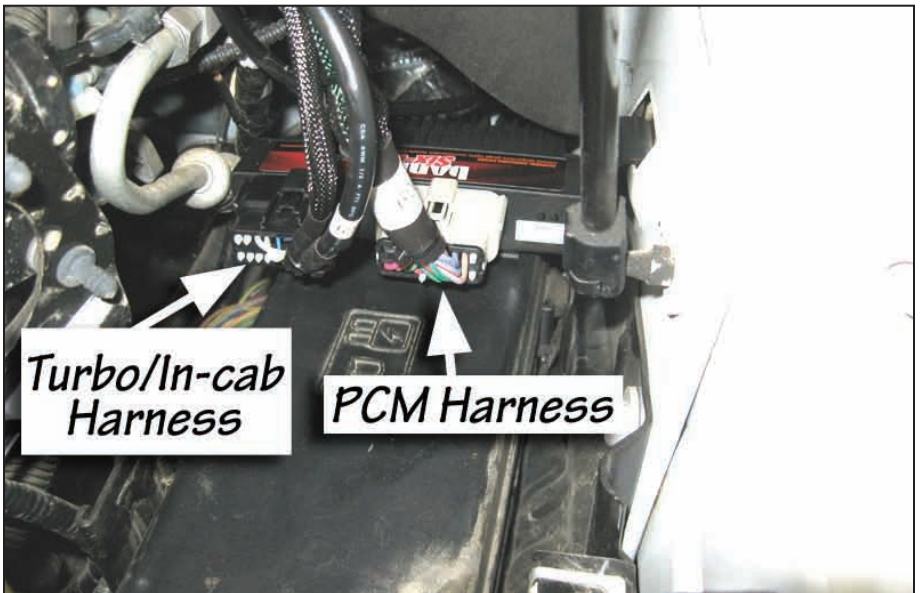

Section 2

INSTALLATION OF OPTIONAL BANKS BRAKE WIRE HARNESS

If you are not installing the Optional Banks Brake Skip to Section 3.

If an existing Six-Gun Tuner has been previously installed, verify that the Tuner has the latest version firmware. Check and compare to the current version available on the Banks website. Banks Brake may not function properly if Six-Gun Tuner firmware isn't up to the current version. If the Tuner is not to the latest version contact Customer Support (888) 839-5600 before continuing with installation.

Installing Banks Brake Wire Harness

1. From inside the engine compartment, locate the factory brake pressure sensor connector on the brake master cylinder. The brake pressure sensor will be the connector farthest away from the firewall. See **Figure 9**. Disconnect the factory brake pressure sensor connector.

2. Locate the Brake Pressure Sensor harness in your kit. See **Figure 10**. Connect the female connector on the Brake Pressure Sensor harness to the factory male connector. Connect the male connector on the Brake Pressure Sensor harness to the factory female connector.

3. Route the 2-pin connector on the Brake Pressure Sensor harness following the six-gun in-cab cable through the fire wall. Secure the wiring harness with the supplied cable ties away from any heat source or moving parts.

4. From inside the vehicle, continue to pull the cable through the firewall until it is approximately 22" inside the cab. Secure the cable to the lower access panel area. Take precaution to leave the three connectors accessible for usage further in the installation process.

5. From under the dash, pull the 2-pin connector on the Brake Pressure Sensor harness through the fire wall.

Figure 9 Brake Pressure Sensor

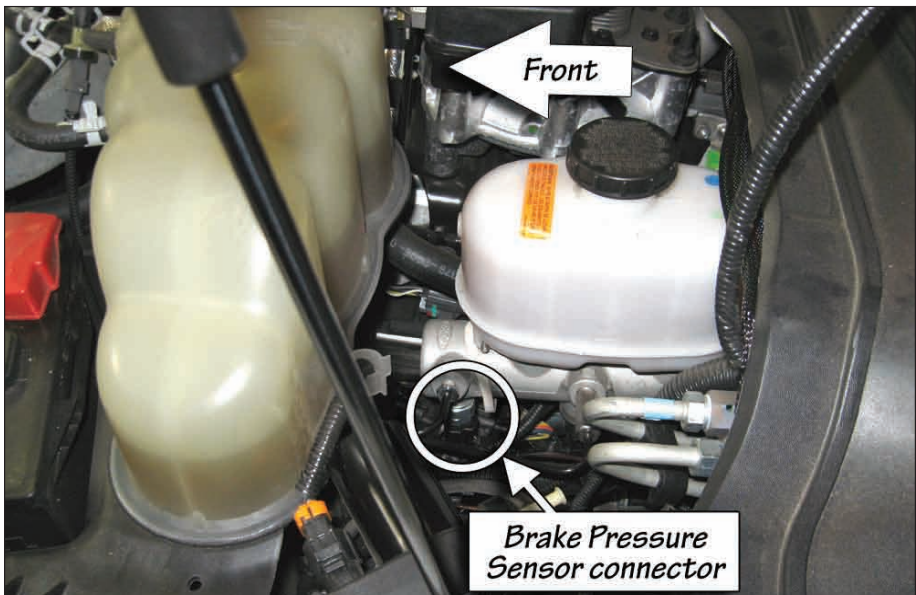

6. Locate the Banks Brake Wire Harness and connect the 2-pin male connector on the Brake Pressure Sensor harness to the 2-pin connector on the Banks Brake wire harness.

Installing Banks Brake Wire Harness

7. Connect the Banks Brake Wire Harness OBD II connector to the vehicle's OBD II connector. Use a cable tie, as shown in **Figure 11** to secure the Banks Brake Wire Harness to the vehicle's OBD II connector.

8. Connect the 8-pin connector from the Banks Brake Wire Harness to the 8-pin connector on the Six-Gun In-Cab Cable.

9. Locate the Foot Brake position switch connector under the dash. See **Figure 12**. Disconnect the foot brake position switch connector.

10. Locate the Brake Position Switch intercept connectors on the Banks Brake Wire Harness. Connect

the female connector on the Brake Position Switch intercept connectors to the factory black brake position switch connector. Connect the male connector on the Brake Position Switch intercept Connectors to the factory female brake position connector that was disconnected.

11. From under the steering column, loosen the screws that hold the steering column panel covers in place.

12. Move the steering column down to the lowest possible position to aid in removal of the top steering column panel. Remove the top steering column panel. See **Figure 13**.

CAUTION: Be careful when removing the top steering column panel or damage may result.

13. Locate the tow haul connector towards the top rear of the steering column. See **Figure 14**.

14. Disconnect the tow haul connector.

Figure 10 Banks Brake Wire Harness

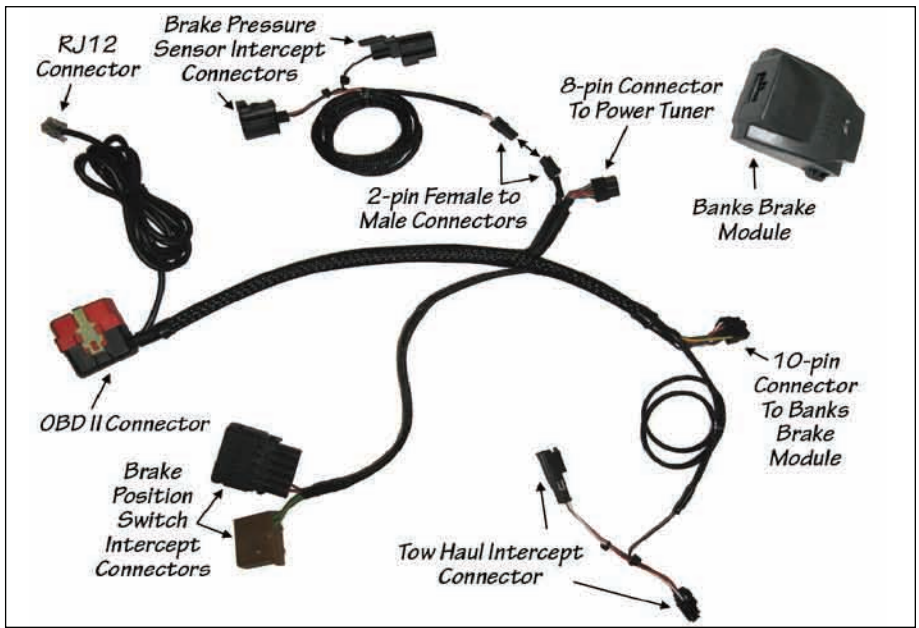
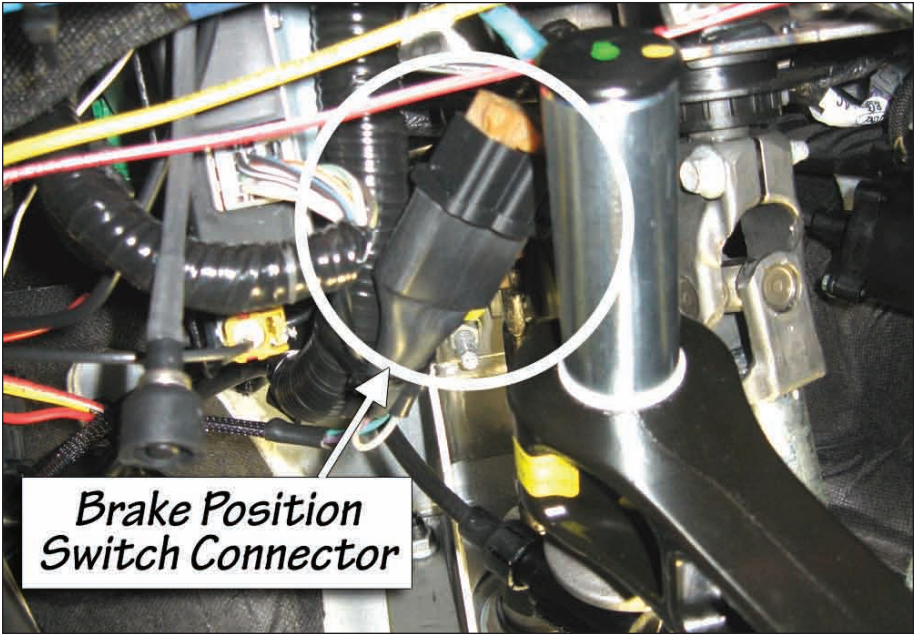

Figure 11 OBDII Connector



Figure 12 Brake Position Sensor location under dash



15. Locate the tow haul intercept connector on the Banks Brake Wire harness. Route the Tow Haul intercept connectors under the dash towards the front of the vehicle and up to the top of the steering column following the factory harness to the factory tow haul connector. Make sure the connectors and wires are free of rotation from the steering column. Connect the female connector on the Tow Haul intercept connectors to the factory male tow haul connector. Connect the male connector on the Tow Haul intercept connectors to the factory female tow haul connector. Secure the connectors and wires with supplied cable ties.

16. Connect the Brake module 10-pin connector on the Banks Brake wire harness to the Brake module. The connector will be the only one with a label.

NOTE: Make sure the correct connection is made to the Tuner and the Banks Brake before proceeding.

17. Secure Brake Module under the dash to any dash frame support or main wiring harness using the supplied cable ties. Use the cable tie support loops on the side of the Brake Module to securely fasten it under the dash. See **Figure 15**.

NOTE: Make sure to mount the Brake Module under the dash away from moving parts and where it cannot obstruct feet movement.

18. Install the top steering column panel back in place.

19. Reinstall the factory screws to fasten the steering column plans back together.

20. Go over all connections. Secure the wire harness with the supplied ties under the dash.

WARNING: Take care to keep any cables away from the pedals or where they could become tangled.

-END, SECTION 2-

Figure 13 Remove top column panel cover

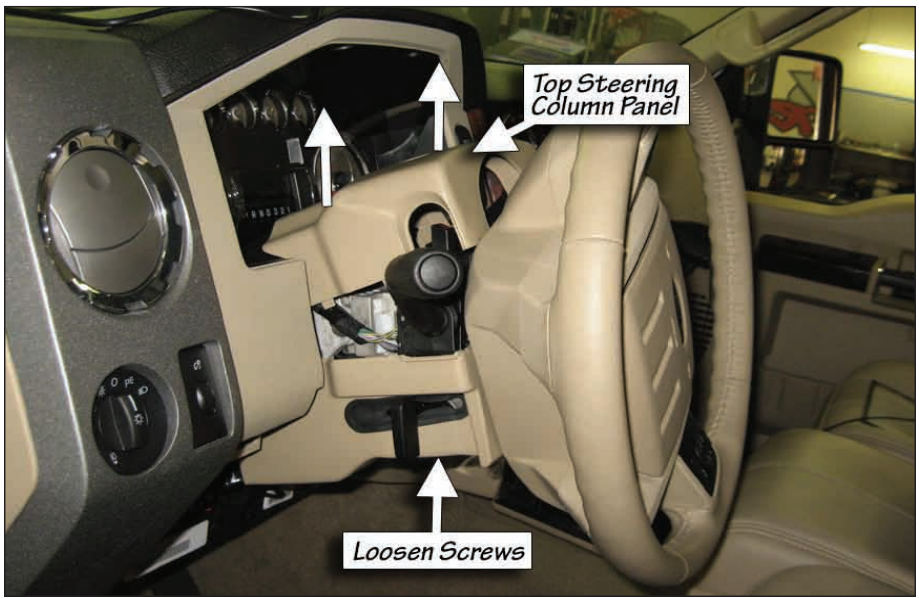
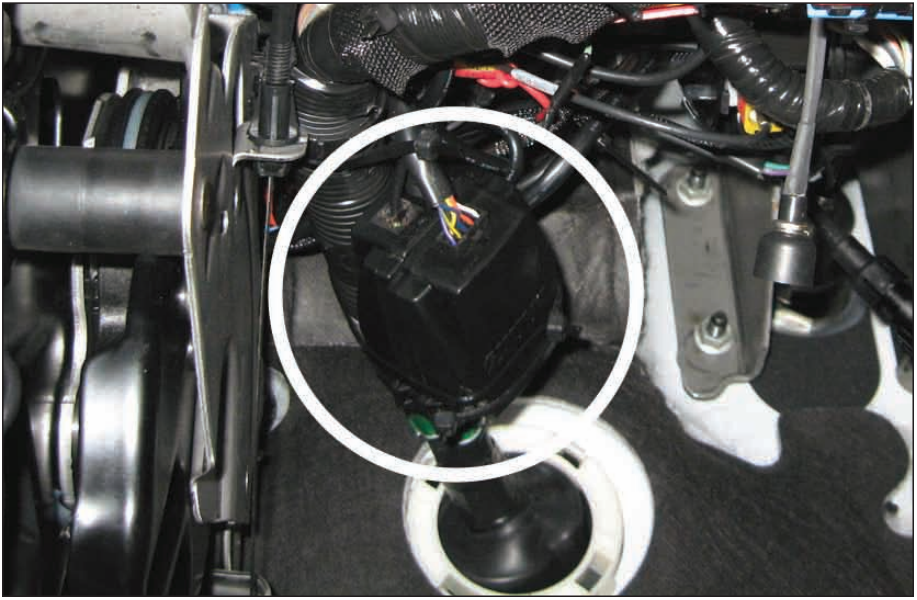

Figure 14 Tow Haul Connector on steering column, under main harness



Figure 15 Banks Brake Module mounting location



Section 3

INSTALLATION OF THE BANKS SIX-GUN & BANKS BRAKE SWITCH

Caution: Do not use excessive force when working on plastic parts. Permanent damage to the part might result.

1. Remove the Center Finish Panel by removing the two (2) screws behind the screw panel covers and pulling out on the panel. Disconnect any electrical connectors. See **Figure 16**.

2. Remove four (4) screws that hold the instrument cluster in place. See **Figure 17**. Retain hardware for reuse.

3. Apply the parking brake and put the vehicle in the lowest gear possible. Remove the instrument cluster by pulling out. Disconnect any electrical connector.

4. Cut out the template in **Figure 24** on page 35, and tape to the front of the instrument cluster panel as shown in **Figure 18**. The template will be used as a guide for drilling the holes to locate the Banks Six-Gun and Banks Brake switch.

If you are only installing a Six-Gun switch, skip Step 5 and use only the bottom hole in the template.

5. Remove the plastic honeycomb pattern from the back of the cluster panel around the top hole to make sufficient room for the switch. See **Figure 19**. To ease process use a die grinder to remove the plastic honeycomb pattern.

6. If only installing a Six-Gun switch, only use the bottom hole in template. Using a $1\frac{3}{32}$ " Uni-drill, center the bit onto the $1\frac{3}{32}$ " drill locations on the template and slowly drill through. Using a $\frac{1}{8}$ " drill bit, center and drill through the $\frac{1}{8}$ " location(s) on the template. Remove and discard the template and any plastic shavings. De-burr the drilled hole(s) as needed to ensure that the Six-Gun/Brake switch(s) fit(s) squarely against the dash panel.

7. Remove the nut(s) and internal tooth washer(s) from the Six-Gun/Brake switch(s) and test fit the switch(s) into the drilled hole(s). Ensure that the alignment pin(s) properly fit(s) in the $\frac{1}{8}$ " hole(s). Enlarge the hole(s) as necessary to allow the switch(s) to properly fit. Do not fasten the switch(s) to the dash panel yet.

Figure 16 Remove screw covers to access screws in center finish panel

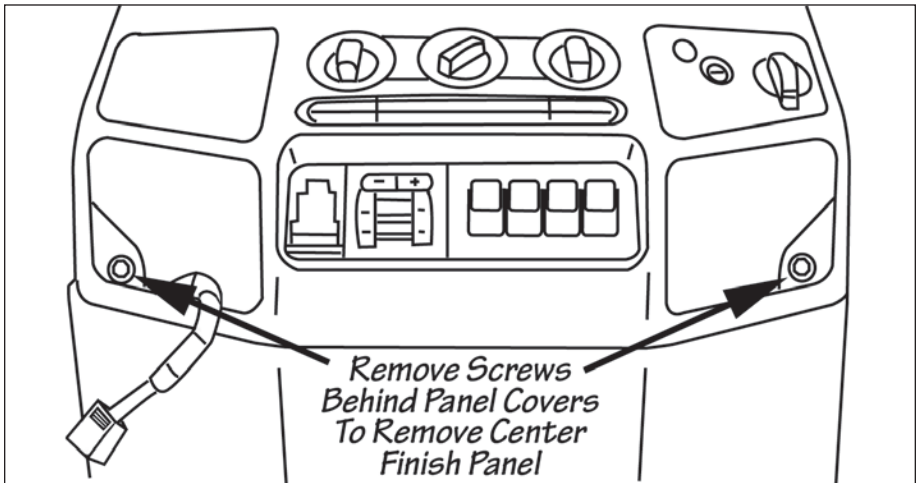

Figure 17 Removal of the Instrument Cluster Panel

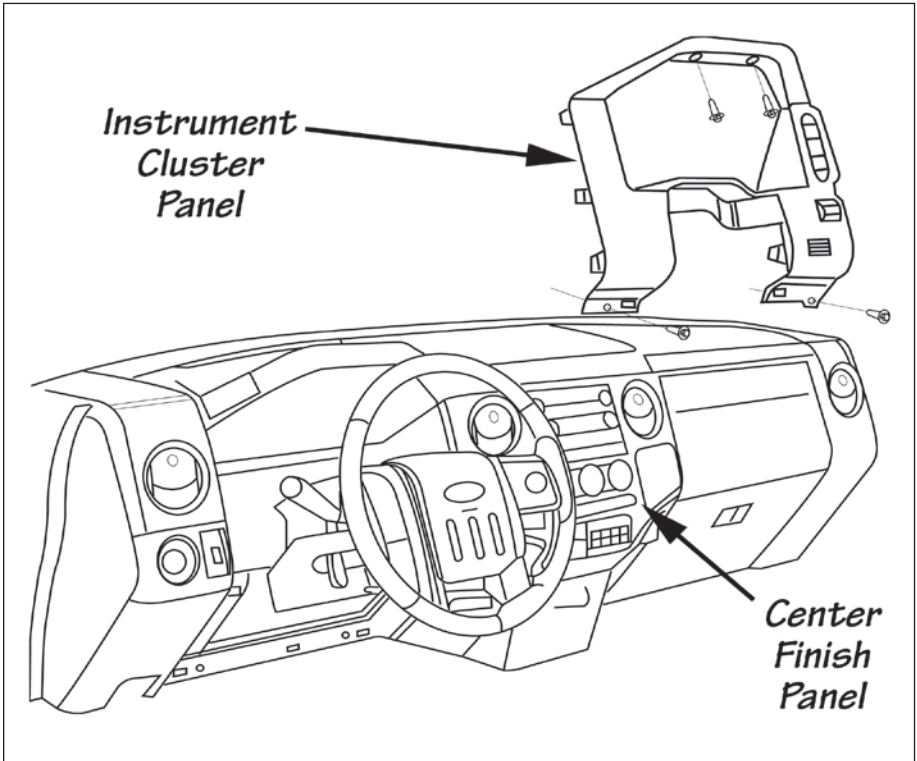
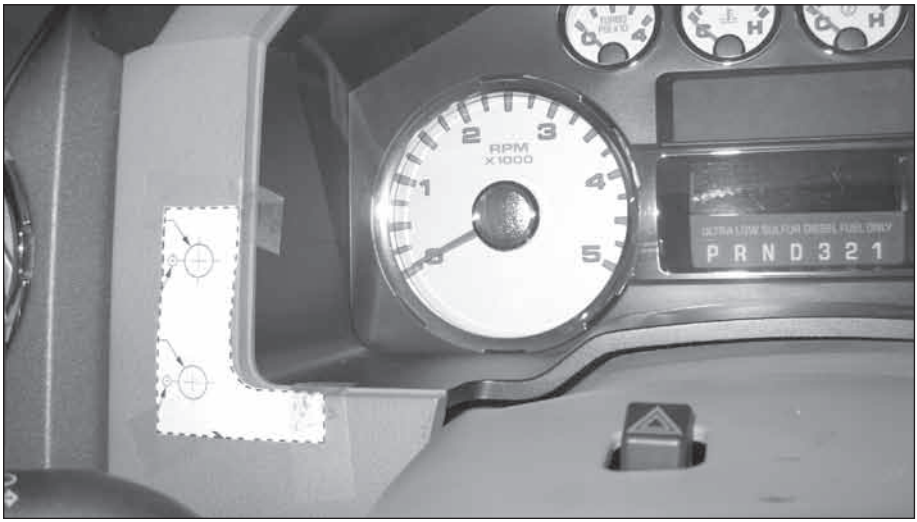

Figure 18 Template taped to front of instrument cluster



8. Align the Banks Six-Gun and Brake label on the previously drilled holes on the front of the dash panel. Make sure the entire mounting surface is clean and free of dirt and oil before mounting the label. Clean and dry as required using a cloth dampened with rubbing alcohol or similar cleaning solution. Remove the adhesive backing and affix the label to the dash panel. Hold the labels against the panel for approximately 20 seconds while applying pressure to allow the adhesive to properly adhere to the surface.

9. Rotate the switches counterclockwise until the shaft stops. Verify that the Six-Gun washer tab is inserted into the #6 position and that the Brake washer tab is inserted into the #5 position on the switch as shown in **Figure 20**.

NOTE: All of the Six-Gun and Brake settings may not be usable if the tabs are not inserted into the proper position.

10. Install the switch through the $\frac{13}{32}$ " hole on the backside of the bezel. The alignment pin should rest in the $\frac{1}{8}$ " hole and the switch fully rotated counterclockwise. Secure the

switch with the internal tooth washer and nut. Snug the nut. Be careful not to over-torque the nut and damage the threads.

11. Install the knob on the shaft facing the "OFF" setting for the Banks Brake and the "1" setting for the Six-Gun. On the knob, snug the two (2) set screws with the supplied 0.050" hex key wrench. The completed switch installation will appear as shown in **Figure 21**.

If not installing the optional Banks Brake, skip step 12.

12. Route the RJ12 connector (phone like connector) to the Banks Brake switch cable connector, and plug the connectors. Secure all loose wiring under the dash with supplied cable ties.

13. Re-install the instrument cluster, make all electrical connections that were disconnected, and secure with the factory screws.

14. Re-install the Center Finish Panel, make all electrical connections that were disconnected, and secure with the factory screws.

Figure 19 Remove the plastic around the top hole for switch placement

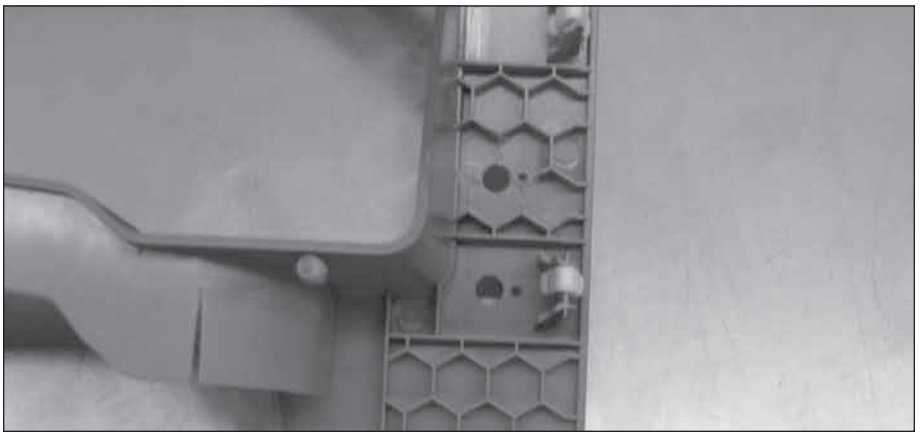

15. Route the Six-Gun switch's cable to the wire harness that was routed into the passenger compartment from the Six-Gun Diesel Tuner, and plug the 2-pin connector into the corresponding connector on the Six-Gun harness.

NOTE: The 6-pin plug on the wire harness routed from the Six-Gun module to the passenger compartment

will not be used by the Banks Six-Gun.

WARNING: Take care to keep any cables away from the pedals or where they could become tangled.

16. Re-install the bottom Steering Column Panel.

-END, SECTION 3-

Figure 20: Banks Six-Gun/Brake switch, orientation of the tab on the washer

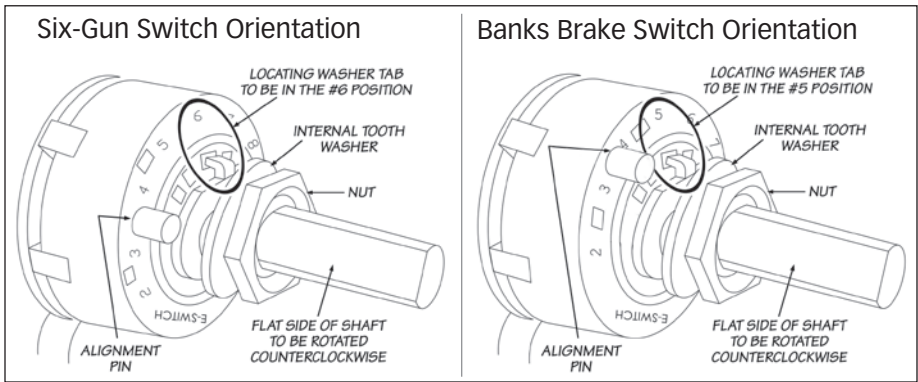
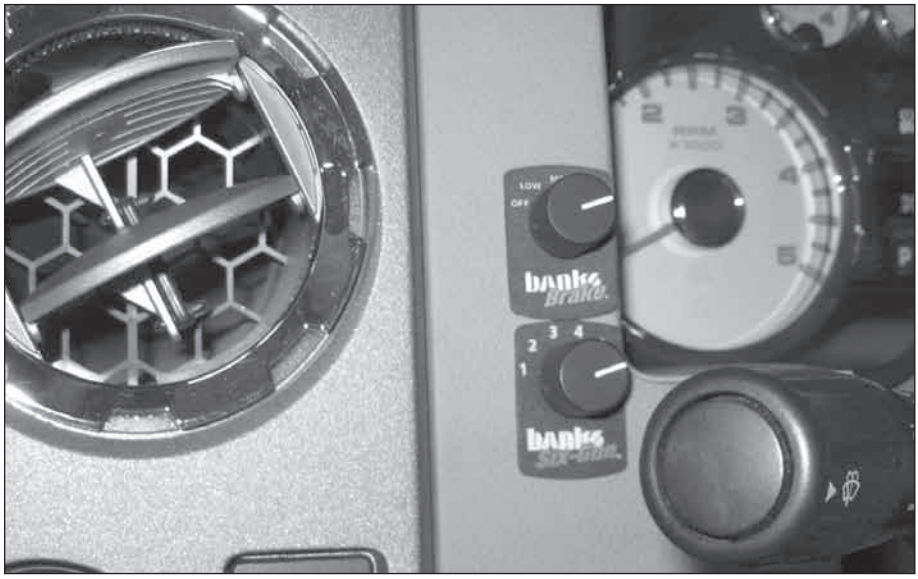

Figure 21 Finished installation of the Six-Gun/Banks Brake Switch



Section 4

BANKS BRAKE OPERATION

The Banks Brake has five (5) operating settings; OFF, LOW, Medium (MED), HIGH and Foot Brake Activation (FB). See **Figure 34**.

OFF mode allows the vehicle to behave as if the Banks Brake is not present.

When the selector switch is turned to the LOW, MED, or HIGH the Banks Brake will activate and begin slowing the vehicle any time the accelerator pedal is not applied and the vehicle speed is greater than 15 mph.

LOW strength setting achieves a lower level of braking force and is recommended for lightly loaded or unloaded vehicles. The LOW setting may also be used for daily driving.

MEDIUM (MED) strength achieves a moderate level of braking force by slightly delaying transmission downshifts. This setting is recommended for moderately loaded vehicles.

HIGH strength achieves the highest level of braking force by aggressively downshifting the transmission and closing the turbocharger vanes. This setting is recommended for heavily loaded vehicles or whenever aggressive braking is desired.

CAUTION: Using the HIGH setting with a lightly loaded vehicle will result in VERY aggressive braking. Become familiar with the characteristics of the Strength Settings before encountering slippery road conditions, including rain, snow and icy.

Foot Brake Activation

When Foot Brake Activation is selected the Banks Brake will only activate when the foot brake is applied. In this setting the Brake will apply the highest level of braking force to assist in slowing the vehicle.

To Enable Foot Brake Activation, turn the Brake selector switch to the Foot Brake Activation (FB) Level. To Disable, turn the switch to any other desired level.

CAUTION: Your Banks Brake is NOT a substitute for the hydraulic brakes on your truck. The device will not correct or compensate for improperly maintained hydraulic brakes. Also, please be aware that your Banks Brake is not designed to be used as a parking brake or to bring your vehicle to a complete stop. Your Banks Brake is a supplementary braking system designed to help you slow down or to assist you in maintaining a more constant speed when descending a grade. Remember that Banks Brake is first and foremost a preemptive device and is most efficient when used to help prevent, rather than correct, a vehicle over speed situation.

The use of a Banks Brake does not increase the load capacity of your vehicle. Gross combined Weight Rating specifications should always be adhered to. The Banks Brake will allow you to slow your vehicle more effectively within your vehicle's weight specifications.

OPERATION/DRIVING

Now that you are familiar with the features that are available with Banks Brake, it is recommended that you experiment with the various settings prior to using the braking features in a towing or extreme driving situation. Under light load conditions on local streets, the MEDIUM (MED) setting is an appropriate starting point to provide a reasonable demonstration that the brake is functioning.

NOTE: Whenever the brake is active and the footbrake is applied, the vehicle will not upshift until the throttle is pressed. This is also true even if cruise control is resumed.

For some model vehicles, whenever the brake is active the vehicles Tow-haul mode will deactivate. The tow-haul mode will deactivate when the Banks Brake is deactivated.

WHEEL SLIP DETECTION

The Banks Brake continuously monitors wheel speeds to detect possible slippage caused by braking. If this occurs, the brake will shut off until traction is regained and then remain off for 30 seconds. This will be communicated as a fault via the Banks iQ Status Indicator.

-END, SECTION 4-

Figure 22: Banks Brake Selector Switch Guide

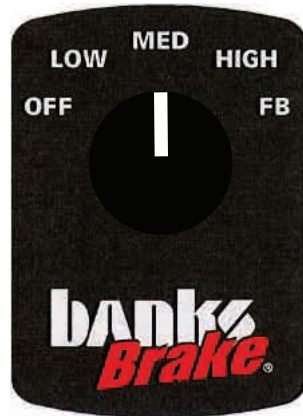

Section 5

AUTOMATIC TRANSMISSION LEARNING

The 6.4L Ford Trucks equipped with the TorqShift™ 5-speed automatic overdrive transmission use an adaptive shift control logic. This will require the transmission to learn how to cope with the additional power created by the Banks Power products before it will shift properly. Additionally, the Banks Six-Gun Diesel Tuner will require a short learning curve to characterize the transmission in order to optimize fueling during gear change events. The following sequence must be followed to allow for collaborative learning between the Banks Six-Gun and the transmission's control system. Failure to follow the sequence can result in damage to the transmission.

Perform the following sequence at a location where it is safe to accelerate to 60 mph without exceeding the posted speed limit.

- 1.** Start the truck and allow the engine to reach normal operating temperature.
- 2.** Set the Banks Six-Gun switch to power level 2.
- 3.** Accelerate with the pedal to the floor, from a standing start to 60 mph. Repeat three (3) times.
- 4.** Cruise at 30 mph, then press the accelerator to the floor to cause the transmission to downshift. Continue accelerating to 60 mph.
- 5.** Repeat **steps (2) and (3)** for the next power setting.
- 6.** Continue to increase the power setting and drive cycle until the desired power setting is achieved.

*The TorqShift™ 5-speed automatic transmission will continually adapt to the power output of the engine to optimize shift quality. This will result in the transmission un-learning how to cope with the higher power settings of the Six-Gun Diesel Tuner, if the Six-Gun Diesel Tuner is returned to a lower power setting. The rate that the transmission un-learns how to cope with the higher power levels, when switching to a lower power level, depends on the driving cycle. The transmission will quickly adapt to the power setting if the driving cycle includes regular gear changes at high loads. **The transmission learning procedure will need to be repeated when switching back to the higher power settings once the transmission adapts to the lower power settings.** It will be apparent when the transmission adapts to the lower settings by monitoring the feel of the gearshift. Gear changes will be noticeably harder when initially switching from a higher to lower power setting. This will soften as the transmission adapts to the new setting.*

For example: If the transmission has adapted to level 3 and it is desired to go to level 6, the transmission learning procedure can start at level 3.

IF TRANSMISSION SLIP IS DETECTED DURING THE TRANSMISSION LEARN PROCESS, REDUCE THE POWER LEVEL BY ONE, AND START OVER AT STEP 3.

-END, SECTION 5-

Section 6

CHECKING ENGINE PERFORMANCE

The Six-Gun Diesel Tuner requires the engine coolant temperature (ECT) to be above 110° before it will add fuel. If the optional DynaFact® gauges are installed, observe the operation of the boost and pyrometer (EGT) gauge values while driving under varying conditions. Turbocharger boost pressure will increase as a function of load and engine RPM, thus the engine will produce little boost while cruising at light throttle, with maximum boost while climbing hills heavily loaded during acceleration. Note the boost level seen during hard acceleration with a given load. If performance seems to have deteriorated sometime in the future, the maximum boost figures may be compared to see if boost has dropped off. Lower boost may be caused by turbo ducting leaks, a malfunctioning wastegate or fuel injection pump, or dirty air filter. Typical maximum boost pressure settings will vary considerably with stick or automatic transmission options, year model of vehicle and altitude.

NOTE: Before key-off, check tuner for error codes.

Use your EGT gauge to monitor exhaust gas temperature (EGT) in the engine. At idle, exhaust gas temperature will be very low, perhaps only 300°F. As the engine is accelerated for higher speeds with greater loads, the EGT will rise. The highest EGT will be seen under maximum load at full throttle, such as climbing a steep grade with a heavily laden vehicle.

To avoid heat damage to various engine components it is recommended that the exhaust gases cool below 400° before the engine is shut down. Your Six-Gun Diesel Tuner is calibrated to maintain a maximum EGT of 1350°F. You may experience brief excursions slightly above 1350°F under acceleration. This is normal and EGT should return to 1350°F or below within a few seconds. If you find that EGT remains high for any length of time, check for boost leaks or a dirty air filter.

-END, SECTION 6-

Section 7

TROUBLESHOOTING

If an existing Six-Gun Tuner has been previously installed, verify that the Tuner has the latest version firmware. Check and compare to the current version available on the Banks website. Banks Brake may not function properly if Six-Gun Tuner firmware is not up to the current version.

Six-Gun & Brake Troubleshooting (Using Tuner/Module LED's)

If you feel that your Six-Gun Diesel Tuner and/or Banks Brake is not functioning properly, some diagnostics can be performed. Your Six-Gun Diesel Tuner and Banks Brake is equipped with diagnostic features that will detect and display certain errors. Remove the Six-Gun Diesel Tuner and Banks Brake from its mounting location while keeping all connectors plugged in. Turn the vehicle key to the ON position. Observe the two LEDs mounted on the upper corner of the brake and/or the Six-Gun Diesel Tuner.

- *A steady GREEN LED will illuminate* if all wire connections are correct, the engine is running and the engine coolant temperature is within its normal operating range.
- *The GREEN LED will flash* if all wire connections are correct, the engine is running, but the engine coolant temperature is not within its normal operating range. The GREEN LED will stop flashing once the engine coolant temperature is with normal operating range. Power will not be added if the coolant temperature is not within its normal range.
- *None of the LEDs will illuminate* if the fuse on the Six-Gun wiring harness is blown or the power supply hook-up is not properly connected. If the power connection and fuses are okay, contact Banks Technical Service.

- *The RED LED will flash* if a connection is incorrect or if there is a problem with the system, when the engine is running. The RED LED will flash in sequence to identify a particular fault code. A Six-Gun Diesel Tuner's fault code is comprised of 2 digits. Each code is expressed in a sequence of 2 sets of the flashing RED LED separated by a brief flashing of the GREEN LED. Each set of a number of RED LED flashes represents a digit. A longer flashing of the GREEN LED separates the sequences. The LEDs will continue to flash to display all the errors, and then repeat.

Table 1 lists the Six-Gun Tuner fault codes.

Table 2 lists the Banks Brake fault codes.

For example, if a faulty thermocouple is detected (code 2,3) by the Six-Gun Diesel Tuner, the following RED and GREEN LED flashing sequence is observed when the key is ON:

- (1) Two times flashing RED LED
- (2) One time quick flashing GREEN LED
- (3) Three times flashing RED LED
- (4) One time longer flashing GREEN LED

The above flashing sequence will repeat continuously. When the problem is corrected, the fault code will be eliminated and replaced with a steady GREEN LED. Note: If multiple codes are set, they will be displayed in a series separated by the longer flashing GREEN LED. When reading codes, make sure to watch the entire series until you see the first code repeat.

-END, SECTION 7-

Table 1: Banks Six-Gun Fault Codes

Code	Event	Course of Action
1,1	Fuel Rail Pressure (FRP) Input Voltage Out of Range.	Turn ignition OFF and check the 96-pin male and female PCM connectors. Turn ignition back ON and re-check for presence of code. If code does not re-appear at key ON, start engine and check for presence of code both at engine idle and under varying driving conditions.
1,2	Manifold Absolute Pressure (MAP) Input Voltage Out of Range.	Turn ignition OFF and check the 96-pin male and female PCM connectors. Turn ignition back ON and re-check for presence of code. If code does not re-appear at key ON, start engine and check for presence of code both at engine idle and under varying driving conditions.
1,3	Six-Gun Switch Input Value Out of Range.	Turn ignition OFF and make sure either Banks IQ or Six-Gun switch is connected to Six-Gun tuner. If Six-Gun switch is connected (no Banks IQ), check 2-pin connection on tuner's in-cab cable. Turn ignition back ON and re-check for presence of code.
1,4	Exhaust Back Pressure (EBP) Input Voltage Out of Range.	Turn ignition OFF and check the 96-pin male and female PCM connectors. Turn ignition back ON and re-check for presence of code. If code does not re-appear at key ON, start engine and check for presence of code both at engine idle and under varying driving conditions.
2,1	Fuel Rail Pressure (FRP) Output Voltage Out of Range.	Turn ignition OFF and check the 96-pin male and female PCM connectors. Turn ignition back ON and re-check for presence of code. If code does not re-appear at key ON, start engine and check for presence of code both at engine idle and under varying driving conditions.
2,2	Manifold Absolute Pressure (MAP) Output Voltage Out of Range.	Turn ignition OFF and check the 96-pin male and female PCM connectors. Turn ignition back ON and re-check for presence of code. If code does not re-appear at key ON, start engine and check for presence of code both at engine idle and under varying driving conditions.
2,3	Mass Air Flow (MAF) Signal Fault.	Turn ignition OFF and check the 96-pin male and female PCM connectors. Turn ignition back ON and re-check for presence of code. If code does not re-appear at key ON, start engine and check for presence of code both at engine idle and under varying driving conditions.
2,4	Exhaust Back Pressure (EBP) Output Voltage Out of Range.	Turn ignition OFF and check the 96-pin male and female PCM connectors. Turn ignition back ON and re-check for presence of code. If code does not re-appear at key ON, start engine and check for presence of code both at engine idle and under varying driving conditions.
If code/problem persists, note conditions when code appears and call Gale Banks Engineering Tech Support.		

Table 1: Banks Six-Gun Fault Codes (continued)

Code	Event	Course of Action
3,1	Engine Position Sensor Fault.	Turn ignition OFF and check the 96-pin male and female PCM connectors. Turn ignition back ON and re-check for presence of code. If code does not re-appear at key ON, start engine and check for presence of code both at engine idle and under varying driving conditions.
3,2	Internal Module Malfunction or Intermittent Power.	Turn ignition OFF and check the 96-pin male and female PCM connectors. Turn ignition back ON and re-check for presence of code. If code does not re-appear at key ON, start engine and check for presence of code both at engine idle and under varying driving conditions.
3,3	EGR Valve Position (EGRP) Input Voltage Out of Range.	Turn ignition OFF and check the 96-pin male and female PCM connectors. Turn ignition back ON and re-check for presence of code. If code does not re-appear at key ON, start engine and check for presence of code both at engine idle and under varying driving conditions.
3,4	OBDII CAN communication error	Turn ignition OFF and check the 4-pin male and female turbo actuator connectors. Turn ignition back ON and re-check for presence of code. If code does not re-appear at key ON, start engine and check for presence of code both at engine idle and under varying driving conditions.
4,1	EGR Valve Position (EGRP) Output Voltage Out of Range.	Turn ignition OFF and check the 96-pin male and female PCM connectors. Turn ignition back ON and re-check for presence of code. If code does not re-appear at key ON, start engine and check for presence of code both at engine idle and under varying driving conditions.
4,2	Transmission Slippage Detected.	Transmission is slipping excessively. Code will automatically clear once transmission stops slipping (repaired).
4,3	Internal Module Malfunction or Intermittent Power.	Turn ignition OFF and check the 96-pin male and female PCM connectors. Turn ignition back ON and re-check for presence of code. If code does not re-appear at key ON, start engine and check for presence of code both at engine idle and under varying driving conditions.
4,4	Internal Memory Malfunction.	Turn ignition OFF. Turn ignition back ON and re-check for presence of code. If code does not re-appear at key ON, start engine and check for presence of code both at engine idle and under varying driving conditions.
If code/problem persists, note conditions when code appears and call Gale Banks Engineering Tech Support.		

Table 2: Banks Brake Fault Codes

Code	Event	Course of Action
1, 1	Insufficient power supply to brake module	Turn Ignition OFF and check connection at fuse tap, 10-pin connection to module and 8-pin connection to Tuner. Turn ignition back ON and re-check for presence of code. If code does not re-appear at key ON, start engine and check for presence of code both at engine idle and under varying driving conditions.
1, 2	Brake signal malfunction while brake is on	Turn Ignition OFF and check connections at 5-pin male and female brake pedal connector. Turn ignition back ON and re-check for presence of code. If code does not re-appear at key ON, start engine and check for presence of code both at engine idle and under varying driving conditions.
1, 3	Insufficient voltage to tow-haul switch	Turn Ignition OFF and check connections at 3-pin male and female tow-haul switch. Turn ignition back ON and re-check for presence of code. If code does not re-appear at key ON, start engine and check for presence of code both at engine idle and under varying driving conditions.
1, 4	Brake Signal malfunction while brake is off.	Turn Ignition OFF and check connections at 5-pin male and female brake pedal connector. Turn ignition back ON and re-check for presence of code. If code does not re-appear at key ON, start engine and check for presence of code both at engine idle and under varying driving conditions.
2, 1	No response to generated OBD ISO messages	Turn Ignition OFF and check connections at OBD II connection. Turn ignition back ON and re-check for presence of code. If code does not re-appear at key ON, start engine and check for presence of code both at engine idle and under varying driving conditions.
2, 2	Brake pressure switch signal malfunction	Turn Ignition OFF and check connections at 2-pin male and female brake pressure sensor intercept connector and 2-pin in-cab cable connector. Turn ignition back ON and re-check for presence of code. If code does not re-appear at key ON, start engine and check for presence of code both at engine idle and under varying driving conditions.
3, 1	Rear wheel slip during braking	Module has detected rear wheel slipping. Code will automatically clear 30 seconds after traction regained.
3, 2	Power Up Error or Internal Module Malfunction	Turn Ignition OFF and check connection at fuse tap, 10-pin connection to module and 8-pin connection to Tuner. Turn ignition back ON and re-check for presence of code. If code does not re-appear at key ON, start engine and check for presence of code both at engine idle and under varying driving conditions.
3, 3	Internal Module Malfunction	Turn Ignition OFF and check connection at fuse tap, 10-pin connection to module and 8-pin connection to Tuner. Turn ignition back ON and re-check for presence of code. If code does not re-appear at key ON, start engine and check for presence of code both at engine idle and under varying driving conditions.
4, 3	Exhaust Back Pressure (EBP) Input Voltage Out of Range	Turn Ignition OFF and check the 96-pin male and female PCM connectors. Turn ignition back ON and re-check for presence of code. If code does not re-appear at key ON, start engine and check for presence of code both at engine idle and under varying driving conditions.
4, 4	Communication failure to brake module.	Turn Ignition OFF and check connections at 10-pin brake module, 8-pin Tuner, and OBD II connector. Turn ignition back ON and re-check for presence of code. If code does not re-appear at key ON, start engine and check for presence of code both at engine idle and under varying driving conditions.
5, 1	Internal Module Malfunction	Turn Ignition OFF and check connections at 10-pin brake module, 8-pin Tuner, and OBD II connector. Turn ignition back ON and re-check for presence of code. If code does not re-appear at key ON, start engine and check for presence of code both at engine idle and under varying driving conditions.

Section 8

CLEARING LEARNED INFORMATION

If the Six-Gun Diesel Tuner has been moved to a different vehicle, or you are instructed to do so by Banks Technical Staff, it is possible to reset all of the parameters that the Six-Gun has 'learned' - presence of an EGT thermocouple or Speed-Loader, etc.

CAUTION: The following procedures can only be carried out with the engine OFF!

1. Turn the vehicle key to ON but **DO NOT** start the engine.

2. Fully depress the throttle pedal and then release it completely. Repeat 5 times. The GREEN LED will flash when this is completed successfully.

3. Turn the key OFF. Wait 30 seconds, or until the GREEN LED goes off and stays off. Turn the key back to the ON position but **DO NOT** start the engine.

4. Fully depress the throttle pedal and then release it completely. Repeat 5 times.

-END, SECTION 8-

Section 9

REMOVAL OF THE SIX-GUN DIESEL TUNER

If the Six-Gun Diesel Tuner should ever need to be removed from the vehicle, perform the following:

NOTE: The ignition must remain in the OFF position throughout the removal process.

1. Disconnect the Six-Gun's PCM connector from the left connection on the PCM.

2. Re-connect the vehicle's PCM connector back into the left connection on the PCM.

3. Disconnect the Six-Gun's turbo actuator connector from the vehicles turbo actuator connection and harness. Re-connect the vehicle's turbo actuator connector.

4. Disconnect the 3 small connectors on the 'In-Cab Cable' and gently pull the cable back through the firewall.

5. Remove the Six-Gun Diesel Tuner, PCM harness and Turbo/In-cab harness from the vehicle.

Failure to follow the above instructions when removing the module will result in a "Check Engine" light on the dash and a Diagnostic Trouble Code being stored in the factory computer, in addition to the engine not running.

NOTE: Banks Brake will not function without the Six-Gun Tuner installed.

-END, SECTION 9-

Section 10

PLACEMENT OF THE BANKS POWER DECALS

Figure 23: Placement of the Banks decals

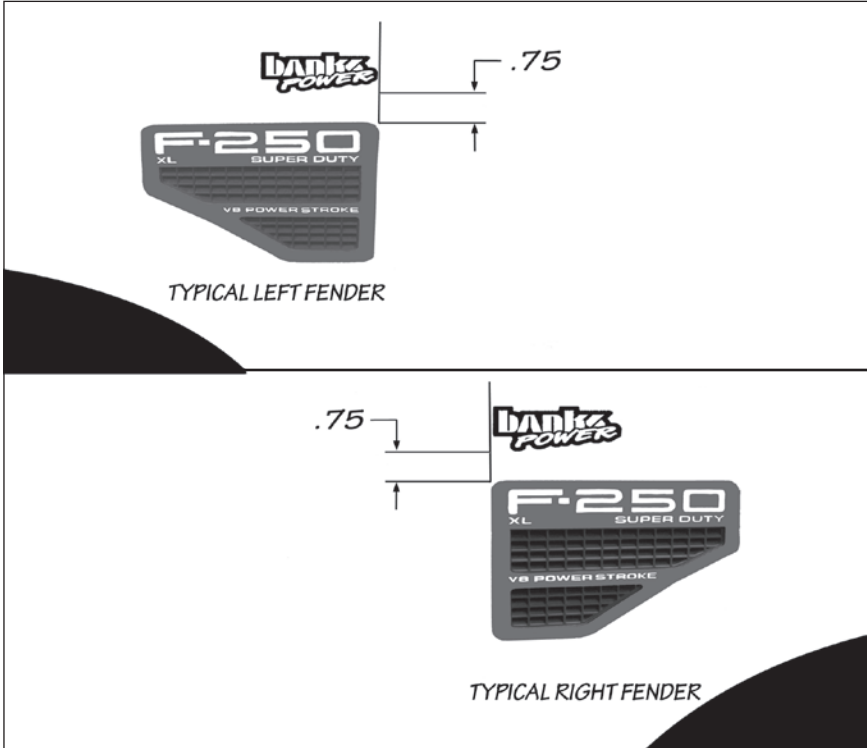

-END, SECTION 10-

NOTES

NOTES

NOTES

Figure 24 *Template for locating the Banks Brake and Six-Gun switch on the dash panel*

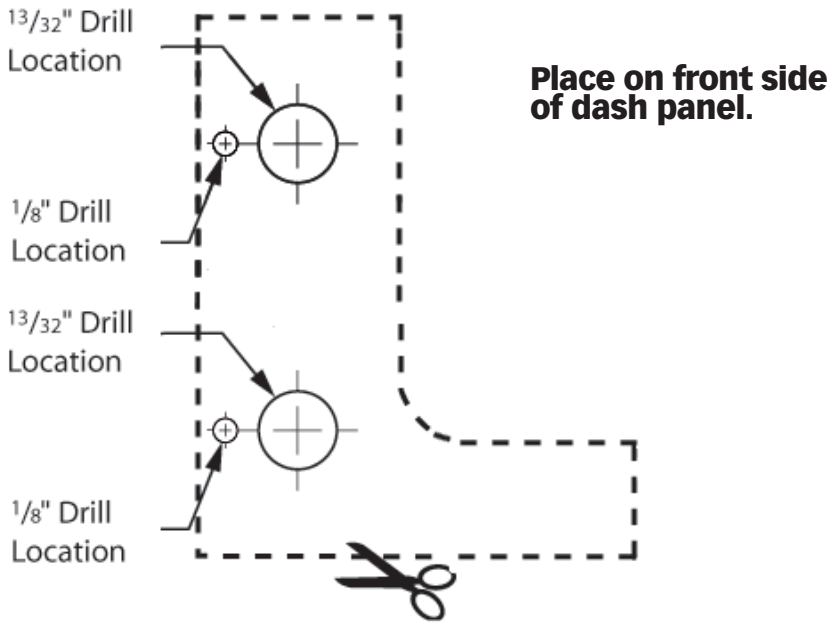

Gale Banks Engineering
546 Duggan Avenue • Azusa, CA 91702
(626) 969-9600 • Fax (626) 334-1743

Product Information & Sales: (888) 635-4565

bankspower.com