

Owner's Manual with Installation Instructions

Banks Split Dual Monster® Exhaust System Quad-Tip

**2007-2009 Dodge 6.7L Cummins
ISB Pickup Trucks
Including Mega Cab**

THIS MANUAL IS FOR USE WITH SYSTEM 49767

Gale Banks Engineering
546 Duggan Avenue • Azusa, CA 91702
(626) 969-9600 • Fax (626) 334-1743

Product Information & Sales: (888) 635-4565

bankspower.com



General Installation Practices

Dear Customer,

If you have any questions concerning the installation of your Banks Monster Exhaust System, please call our Technical Service Hotline at (888) 839-2700 between 7:00 am and 5:00 pm (PT). If you have any questions relating to shipping or billing, please contact our Customer Service Department at (888) 839-5600.

Thank you.

1. Before starting work, familiarize yourself with the installation procedure by reading all of the instructions.
2. The exploded view (**Figure 1**) provides only general guidance. Refer to each step and section diagram in this manual for proper instruction.
3. Throughout this manual, the left side of the vehicle refers to the driver's side, and the right side to the passenger's side.
4. Disconnect the negative (ground) cable from the battery (or batteries, if there are two) before beginning work.
5. Route and tie wires and hoses a minimum of 6" away from exhaust heat, moving parts and sharp edges. Clearance of 8" or more is recommended where possible.
6. When raising the vehicle, support it on properly weight-rated safety stands, ramps or a commercial hoist. Follow the manufacturer's safety precautions. Take care to balance the vehicle to prevent it from slipping or falling. When using ramps, be sure the front wheels are centered squarely on the topsides; put the transmission in park; set the hand brake; and place blocks behind the rear wheels.

CAUTION! Do not use floor jacks to support the vehicle while working under it. Do not raise the vehicle onto concrete blocks, masonry or any other item not intended specifically for this use.

7. During installation, keep the work area clean. Do not allow anything to be dropped into intake, exhaust, or lubrication system components while performing the installation, as foreign objects will cause immediate engine damage upon start-up.

Tools Required:

- 1/2" and 3/8" drive ratchets with standard and metric sockets and 1/2" and 3/8" drive extension
- Standard and metric combination or open-end wrenches
- Standard screwdriver
- Clean shop towels or rags
- Pry-bar

Highly recommended tools and supplies:

- Foot-pound torque wrench
- Oxy-acetylene torch
- Penetrating oil or light lubricant spray
- Reciprocating Saw

Spare tire cannot be placed in stock location with this system.

Also Available from Banks Power

07-10 Dodge 6.7L



Banks Ram-Air Intake System (P/N 42175, 42178)

- Increases your airflow over stock.
- Adds power, improves fuel economy, lowers EGTs and reduces smoke.

Banks Ram-Air Intake Super-Scoop (P/N 42190, 42191)

- Adds cooler denser air to the Ram-Air Intake housing, further increasing fuel economy, reducing smoke and lowers EGTs.

Banks Techni-Cooler® System (P/N 25983)

- Provides increased air flow to the engine by increasing air density for more increased power, lower EGTs and improved fuel economy.

For More Information please call (888) 635-4565
or Visit us online @ www.bankspower.com

General Assembly

Figure 1 Dodge Split Dual Monster Exhaust Parts List

ITEM #	PART #	DESCRIPTION	QTY
1	53298	Intermediate Pipe	1
2	53750	Rear Hanger Clamp	1
3	53993	Y-Pipe	1
4	53321	Left Tailpipe (D/S)	1
5	53322	Right Tailpipe (P/S)	1
6	53290	Frame Hanger Plate	2
7	53291	2" x 2" Hanger Plate	2
8	53732	Rubber Insulator	2
9	91635	7/16-20 x 4" Hex Bolt	2
10	91602	7/16" Washers	4
11	91617	7/16 -20 Nylock Nuts	2
12	52476	4" Exhaust Clamp	3
13	62001	Black 5" Cable Ties	3
14	96009	Banks Power Decals	2

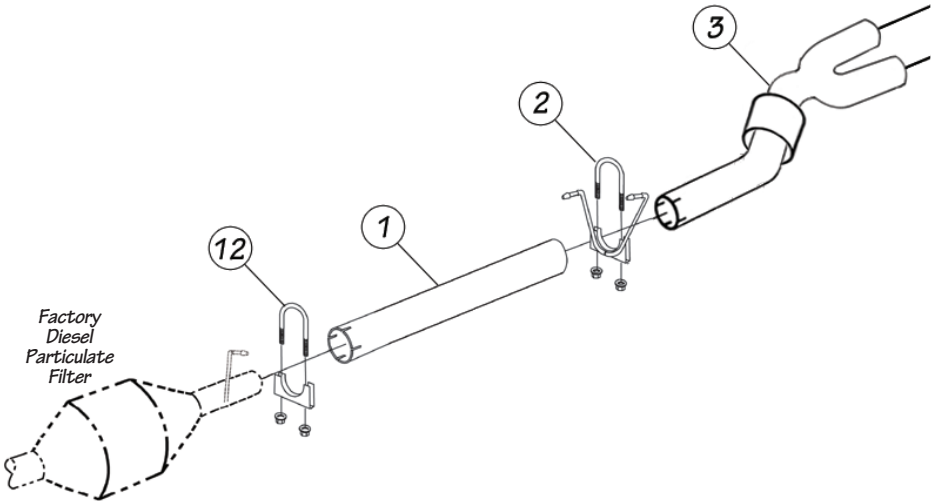

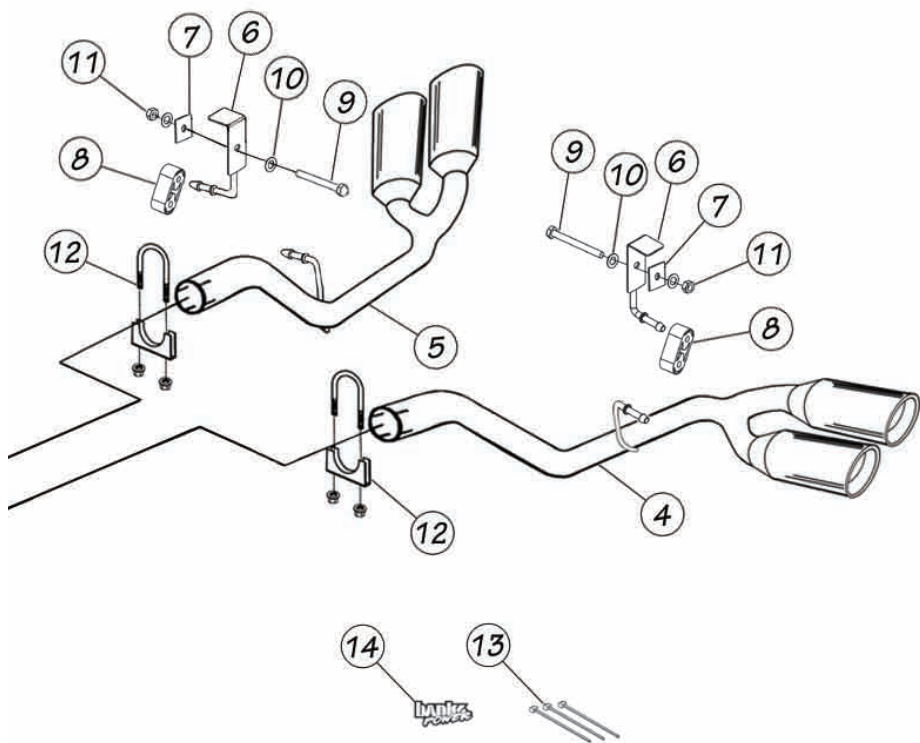

Exhaust System Installation

Spare tire cannot be placed in stock location with this system.

2. Raise the vehicle and support it with properly weight rated safety stands, ramps or a commercial hoist. Follow the manufacturer's safety precautions. Take care to balance the vehicle to prevent it from slipping or falling. When using ramps, be sure the front wheels are centered squarely on the topsides; place the transmission in park; set the parking brake and place blocks behind the rear wheels.

CAUTION: DO NOT WORK UNDER ANY VEHICLE SUPPORTED ONLY BY A JACK. SEVERE INJURY MAY RESULT.

WARNING! The following step may require the use of a torch and/or saw. Proper safety equipment should be used. Failure to use proper safety equipment may result in severe injury.

3. Starting at the rear of the vehicle, remove the tailpipe at the muffler outlet by cutting through the connection or by removing the clamps and heating the joints with an oxy-acetylene torch to allow crimped pipes to separate. Remove the tailpipe from the vehicle.

4. Loosen and remove the clamps on the outlet of the Diesel Particulate Filter to the front intermediate pipe.

TAKE CAUTION TO NOT CUT OR DAMAGE DIESEL PARTICULATE FILTER TUBING DURING THE REMOVAL PROCESS.

Separate the intermediate pipe to Diesel Particulate Filter connection. Remove the intermediate pipe and muffler assembly from the vehicle.

NOTE: the use of an oxy-acetylene torch may be necessary. Remove the muffler hanger pins from the rubber hangers with a pry bar (Spray lubricant will ease hanger removal) and remove the intermediate pipe and muffler assembly from the vehicle.

5. Locate the supplied intermediate pipe and cut the intermediate pipe based on the following configurations. See **Table 1**. Cut the NON-swaged end of the intermediate pipe. See **Figure 2**.

6. Install a 4" exhaust clamp onto the front of the Banks intermediate pipe. Install the intermediate pipe onto the Diesel Particulate Filter outlet. Loosely snug the 4" clamp.

NOTE: Once the pipe has been completely engaged in the slip joint, it should be marked with a marker, scribe or tape for reference when tightening clamps later in the installation. Each slip joint in the system should be marked in this fashion. When the exhaust system is being adjusted to align the hangers, the slip joints can be adjusted so that the reference mark is no more than 1/4" away from its original position.

7. Install the rear intermediate pipe hanger clamp with the two pins facing the front of the vehicle. Insert the two hanger pins into the vehicle's corresponding rubber insulators. See **Figure 3**.

8. Install the Banks Y-pipe into the intermediate pipe as shown in **Figure 1**. Install two (2) 4" saddle clamps onto each Y-pipe outlet (see **Figure 4**).

9. The vehicle spare tire will have to be removed to install the Dual Tailpipes. Using the manufacture tire tools, remove the spare tire and

Figure 2

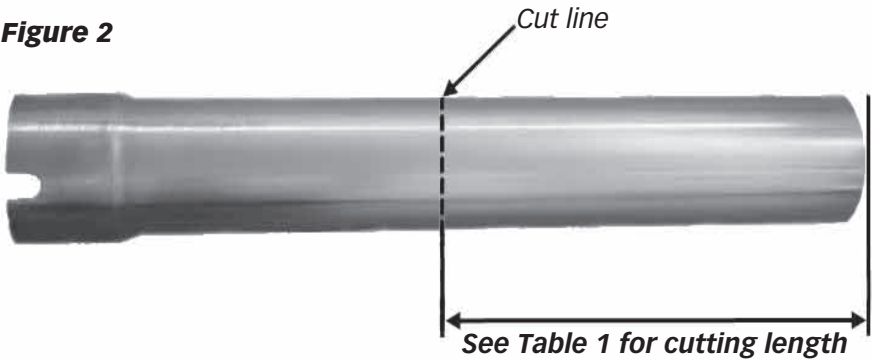

Table 1

2007-2009 Dodge 6.7L Cummins

	Wheel Base	Cut this length from the Intermediate Pipe. See Figure 2 .
Mega Cab/ Short Bed	160.5"	7.375"
Quad Cab/ Long Bed	160.5"	7.375"
Regular Cab/ Long Bed	140.5"	28.5"
Quad Cab/ Short Bed	140.5"	28.5"

Figure 3

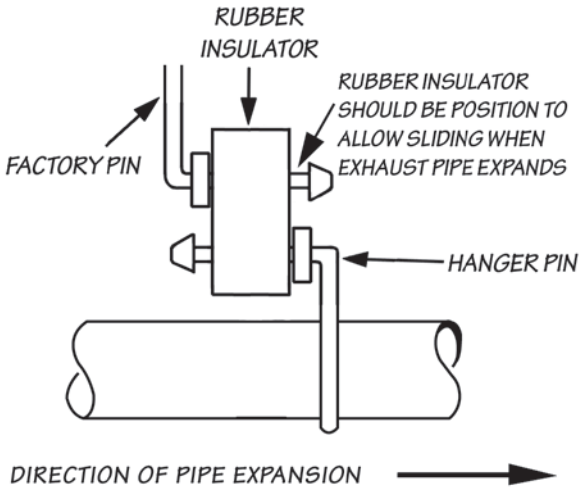
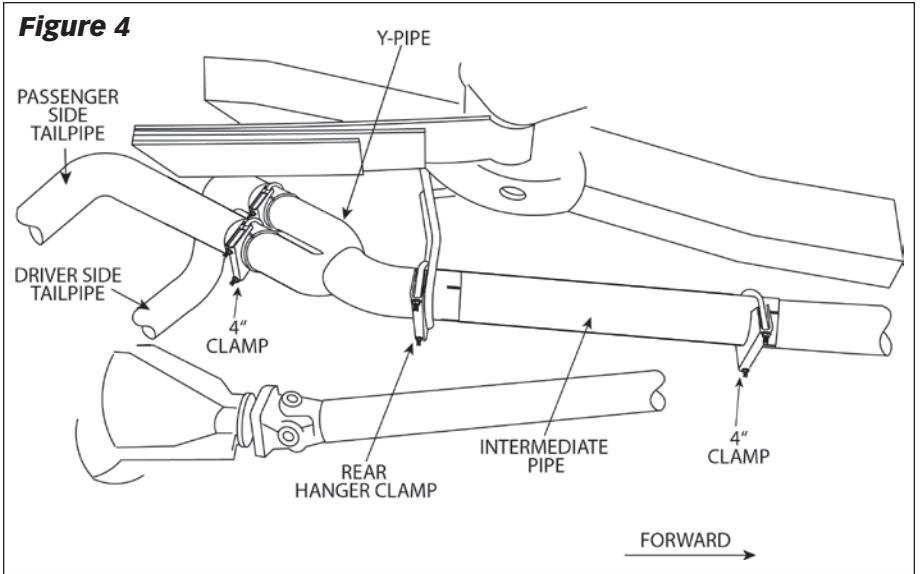

Figure 4



secure the spare tire hoist cable.

10. Install the Banks hanger brackets onto the rear driver-side frame rail behind the rear shock cross member. Place the hanger bracket over the frame rail on the inside. Align the hole in the center of the frame with the hanger bracket. Install the $\frac{7}{16}$ " bolt and washer through the bracket and frame rail. Secure the bolt on the outside frame rail using the $2" \times 2"$ plate, $\frac{7}{16}$ " washer, and $\frac{7}{16}$ " nut. Be sure the hanger pin is parallel with the frame rail and torque all hardware to 48 ft-lb (see **Figure 5**). Repeat this step for the installation of the passenger side hanger brackets.

11. Install the supplied rubber insulators onto the Banks hanger brackets.

12. Install the driver-side tailpipe into the Left Y-pipe outlet. Install the driver-side tailpipe hanger into the vehicle rubber insulator. See **Figure 6**.

13. Install the passenger-side tailpipe into the Right Y-pipe outlet. Install the passenger-side tailpipe hanger into the vehicle rubber insulator. See **Figure 6**.

14. Un-clip the axle vent hose outlet attached to the bed. Re-route the vent hose on top of the fuel tank and attach to the bed. Zip tie the vent hose and brake line to the emergency brake cable, away from the tailpipe.

15. Adjust each of the pipes to ensure that all of the hanger pins are parallel with the frame-mounted pins and fully inserted in the vehicle's rubber insulators.

16. Be sure that the two (2) tailpipes are completely engaged into the Y-pipe. Rotate the tailpipe until the hanger pins are parallel with the frame-mounted pin.

NOTE: Recommended distance between exhaust tip and body is a half ($\frac{1}{2}$) inch.

Figure 5

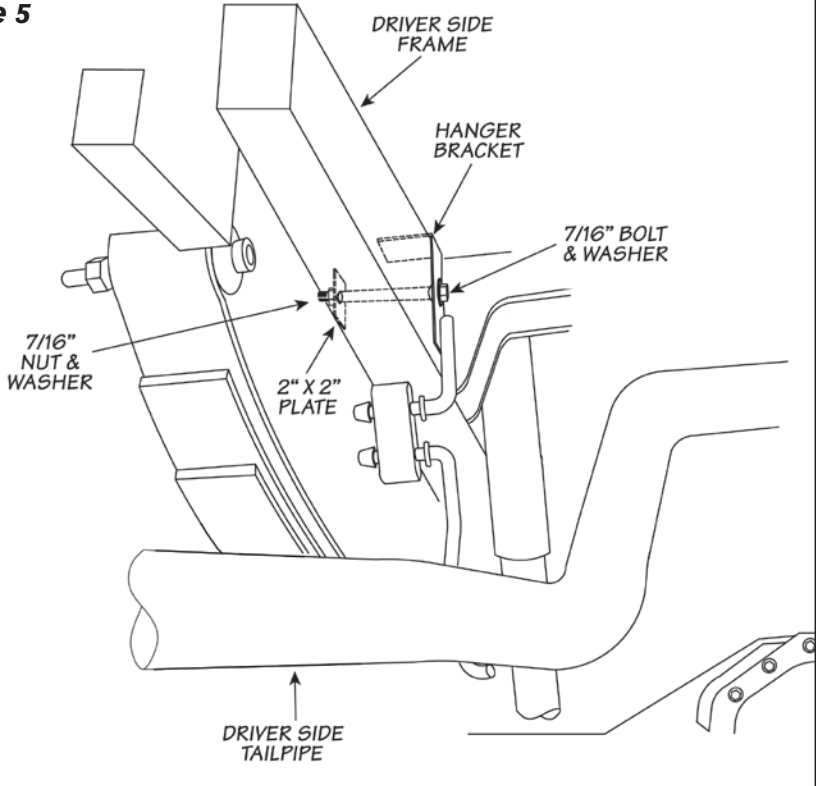
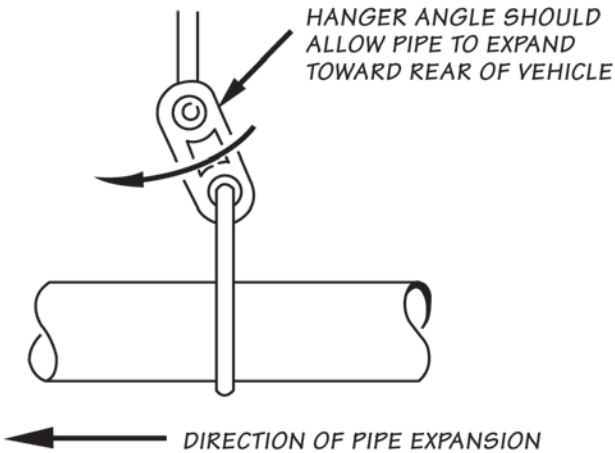

Figure 6



17. With everything positioned properly, begin to tighten the clamps starting with the ones closest to the turbo and working your way back. Evenly torque the exhaust clamps to 35 ft-lbs. Make sure that each slip is fully inserted (+/- 1/4 inch).

18. Remove the protective covering from the tailpipe tips.

CAUTION: The protective covering may ignite and burn if not removed prior to running the engine.

19. Your system includes two (2) Banks power logos. The logos can be mounted 1/2" to 1" above the

"Cummins Turbo Diesel" emblem on the driver-side and passenger-side front fenders.

20. Re-connect battery terminals if previously removed. Start the engine and listen for exhaust leaks. Tighten the exhaust clamps as necessary. Whenever possible, tack weld slip connections to prevent disengagement is recommended.

21. The Banks Monster Exhaust installation is now complete.

Dodge 6.7L Cummins Split-Dual Monster Exhaust System Quad-Tip

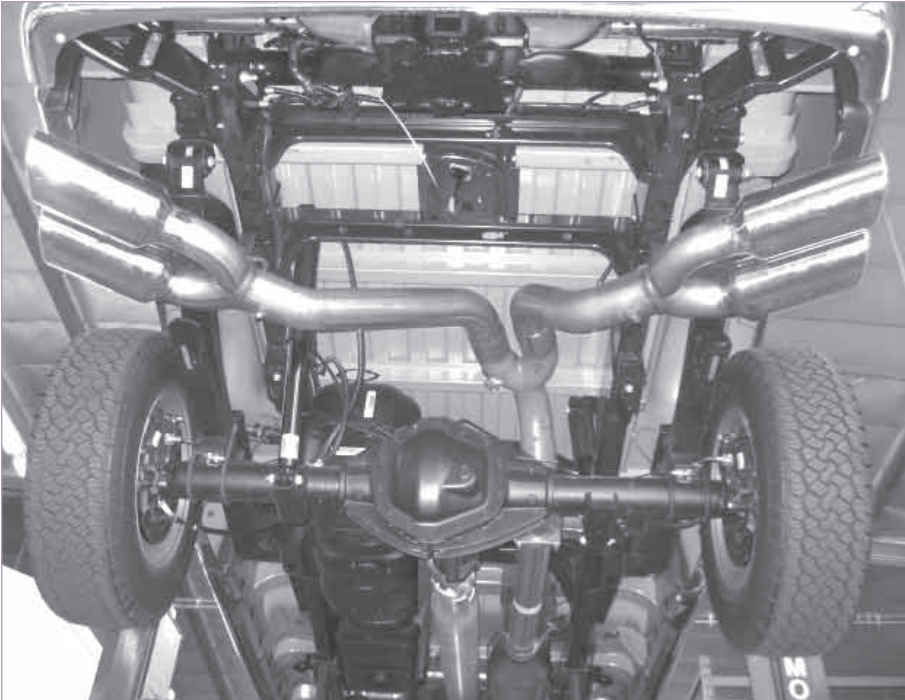

Gale Banks Engineering
546 Duggan Avenue • Azusa, CA 91702
(626) 969-9600 • Fax (626) 334-1743

Product Information & Sales: (888) 635-4565

bankspower.com