

OWNERS MANUAL

WITH INSTALLATION
INSTRUCTIONS

banks

POWERPACK

S Y S T E M

CHEVROLET/GM 454 CARBURETED ENGINE
SINGLE AIR PUMP
CLASS-A MOTORHOME

THIS MANUAL IS FOR USE WITH SYSTEM PART NUMBERS 49051, 49125

GALE BANKS ENGINEERING
546 DUGGAN AVENUE • AZUSA, CA 91702
(626) 969-9600 • FAX (626) 334-1743
Product Information & Sales: (800) 438-7693
www.bankspower.com

PARTS LIST

Item #	Part #	Description	System 49051	System 49125
1	41152	ADAPTOR, Bulkhead, Air Inlet	1	--
	91119	BOLT, 1/4" 20 x 1 1/4" Hex	4	--
	96392	CARD, Product Registration	1	1
	92857	CLAMP, Hose, #56 with Liner	1	--
2	92864	CLAMP, Hose, #64	2	--
3	42513	FILTER COVER, Banks Ram-Air	1	--
4	41013	FILTER ELEMENT, Banks Ram-Air™	1	--
5	52327	FLANGE, Head Pipe, Small	2	2
	93134	GASKET, Air Filter Cover	1	--
6	93158	GASKET, Exhaust Outlet	2	2
	26061	HEATSHIELD, Oil Filter	1	--
	26064	HEATSHIELD, Starter Motor	1	--
7	94089	HOSE, Air Duct 4 x 36"	1	--
8	94128	HOSE, Vacuum, 7/32" x 3'	1	1
	42514	INSERT (Installed in Air Filter Cover)	1	--
	91416	NUT, 3/8" 16 Crimp Lock	6	6
	91110	NUT, 1/4" 20 Nylock	6	--
9	52216	MANIFOLD, Stainless TorqueTube™, Left	1	1
10	52217	MANIFOLD, Stainless TorqueTube, Right	1	1
	96340	OWNERS MANUAL	1	1
	96008	PLAQUE, Banks PowerPack	2	--
	90094	SERVICE KIT, Air Filter	1	--
11	91509	STUD, 3/8 x 2 7/8", NC x NC	3	3
12	91506	STUD, 3/8 -16 x 2 1/4", NC x NC	3	3
	91838	SCREW, Sheet Metal, #6 x 1/4"	4	--
	91840	SCREW, Sheet Metal, #10 x 3/4"	4	--
	42611	STRAP, Mounting	4	--
13	42602	SUPER-SCOOP™, Banks Ram-Air	1	--
14-27	49057	SYSTEM, Monster™ Exhaust	1	--
14	52198	BRACKET, Hanger	1	--
15	91427	BOLT, 3/8" 16 x 1" Hex	5	--
	96362	CARD, Product Registration	1	--
16	52461	CLAMP, Exhaust, 2 1/2"	2	--
17	52465	CLAMP, Exhaust, 3"	9	--
	96024	DECAL, "Replacement Part"	1	--
18	52193	HANGER, Exhaust, Univ Style	3	--
	72150	KIT, Shift	1	--
	90045	LUBRICANT, Anti-Seize, 1 oz	1	--
19	52402	MUFFLER, Dynaflo™	1	--
20	91416	NUT, 3/8" 16 Crimp Lock	5	--
21	26067	PIPE, Chrome Tailpipe Heatsheild	1	--
22	52285	PIPE, Chrome Tip, 3 1/2 x 12"	1	--
23	52250	PIPE, Headpipe, Left, 2 1/2"	1	--
24	52252	PIPE, Headpipe, Right, 2 1/2"	1	--
25	52276	PIPE, Tailpipe	1	--
26	52282	PIPE, Tailpipe	1	--
27	91403	WASHER, 3/8" USS	5	--
	96503	WARRANTY STATEMENT	1	1
	62010	TIE, Cable, 8" Black	6	--
	62003	TIE, Cable, 15" Black	8	--
	91103	WASHER, 1/4" USS	6	--
	--	OPTIONAL EXTENSION KITS:		
	49150	178-208" WHEELBASE	--	--
	49152	209-228" WHEELBASE	--	--

See Figure 1 on page 4 for visual reference

Dear Customer:

Your new Banks PowerPack is a unique combination of air intake, exhaust, and transmission components designed to make the most of your engine's power potential. By removing intake and exhaust restrictions, providing cooler intake air, and tuning the exhaust to create a scavenging effect, your engine can produce more power at a higher level of efficiency. To take advantage of your new found power, this PowerPack includes a transmission governor recalibration kit to raise the shift points of your automatic transmission, as you now have a higher usable engine RPM range. If your driving habits remain the same, your fuel mileage should go up, and you can run on the same octane fuel you are accustomed to using.

If you have any questions concerning the installation of the Banks PowerPack kit, please call Gale Banks Engineering at (626) 969-9600 between 8:00–5:00 PT, and ask for the service department.

Thank You.

GENERAL INSTALLATION PRACTICES

1. For ease of installation of your Banks PowerPack® System, please read this entire 12-page owner's manual before starting any work. (If any pages are missing from this package, please call Gale Banks Engineering immediately for a replacement.) Become thoroughly familiar with all components & phases of the installation before starting any work.

2. Inspect all components supplied for any foreign material that may have entered during shipping and handling.

3. Most motorhomes will need to be raised 5–6" in front to allow the BANKS exhaust manifolds to be slid into place from under the vehicle. This can be accomplished by driving the vehicle upon several sections of 2 x 12 lumber nailed together to form a wedge. **Figure 9** shows how these ramps may be constructed if you are doing your own installation.

4. WARNING! Motorhomes are very heavy. Whatever methods are used to elevate the vehicle must be of sufficient capacity for the vehicle weight involved. **NEVER work under any vehicle supported only by a jack of any kind. DO NOT USE concrete blocks or other masonry items that may collapse under the vehicle weight.**

5. Pay particular attention to the routing of wires and hoses. Keep them away from exhaust heat, moving parts and sharp edges that may cause cuts or other damage. Route or tie away from critical areas as required.

Keep all wires a minimum of 6" from hot exhaust parts, 8" or more is recommended whenever possible.

6. A general assembly diagram is provided in addition to the specific step or section diagrams in the text (**Figure 1**). The general assembly diagram shows relationships of individual components for reference; however, numbered step-by-step procedures should be followed for proper assembly sequence.

7. Right-hand and left-hand designations refer to the driver's right or left, as seated in the vehicle (i.e.: Right-hand refers to the passenger side of the vehicle), unless noted otherwise.

8. The Banks Motorhome PowerPack is designed to fit Class "A" 454 Chevrolet engine/chassis combinations. Because of different equipment layout used by the various coach builders, some accessories and components may have to be relocated to accommodate the air intake components of the Banks PowerPack.

Notification

The Banks Ram-Air Filter comes pre-oiled and no oiling is necessary for initial installation. Service the Banks Ram-Air Filter as specified in the Cleaning and Oiling the Banks Ram-Air Filter Section of this manual.

FIGURE 1

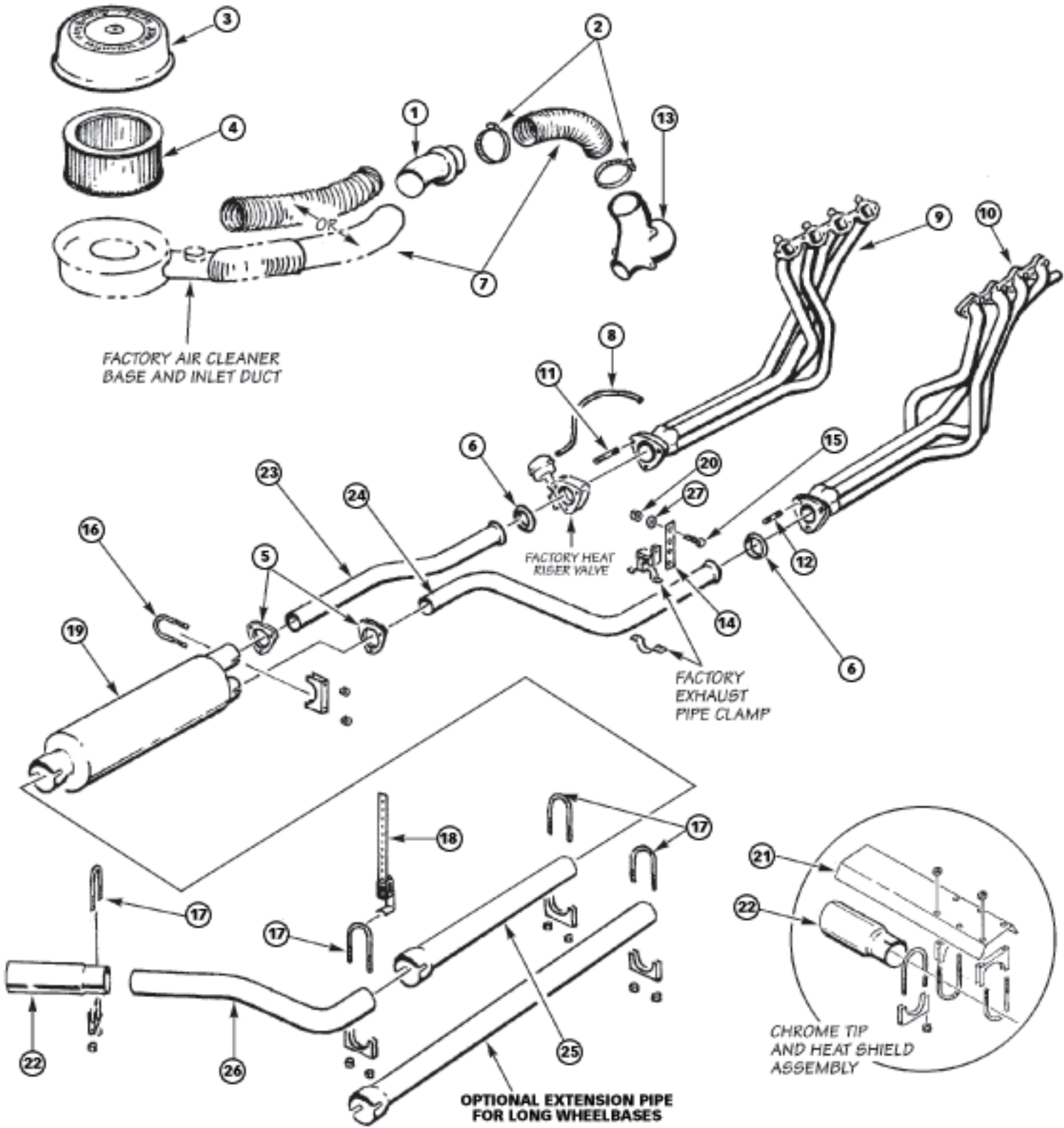

INSTALLATION PROCEDURE

FIGURE 2

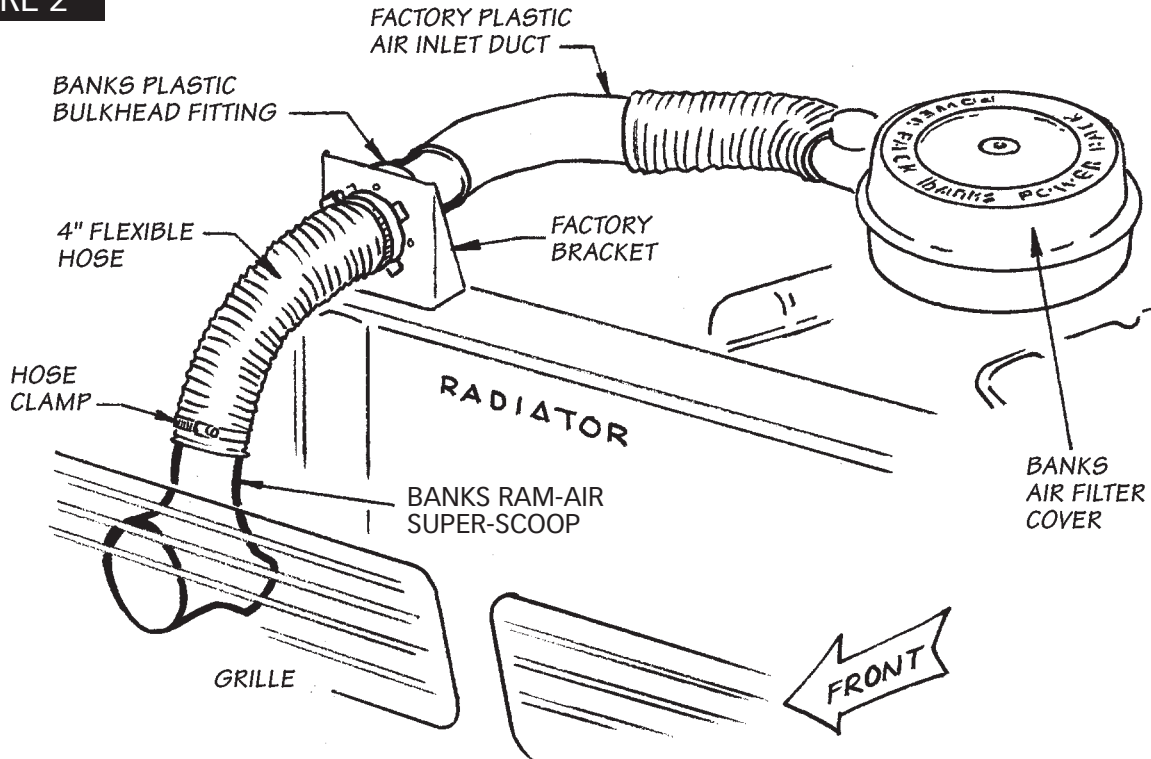

The Banks PowerPack cold air induction components are designed to extend the factory air intake path so that cooler outside air can be picked up from directly behind the vehicle's grille. These components include a molded Banks Super-Scoop™, Banks Ram-Air™ Filter Cover, 4" diameter flexible turbine, a molded bulkhead fitting, and installation hardware. **Figure 2** shows a typical hook-up of the air intake components as they tie to the factory system. The Banks Super-Scoop also serves as a water separator to drain out any rain water that may enter through the grille.

The Banks PowerPack cold air induction package is intended to fit a number of motorhome body configurations. Because each coachbuilder has a different layout of behind-the-grille components, there can be no one set installation procedure for the Banks Ram-Air package. The following instructions are intended as a guideline for installing the Ram-Air system. Also, some coachbuilders may have installed difficult to relocate components (such as air conditioning freon piping) in the areas where the Ram-Air system is normally mounted. In these cases, the installer will have to find an alternate location for the Ram-Air components, or omit those pieces that are impossible to mount.

1. Install the foam gasket strip in the groove around the outside edge of the Ram-Air Filter Cover casting. Peel the paper off the gasket to expose the adhesive. Trim the ends square with a knife or razor blade to form a tight junction. Do not stretch the gasket as you install it.

2. Remove the engine hatch cover from the vehicle. Remove the air filter cover and filter element. Clean any oil or debris from the inside of

the air filter base. Install the new Banks Ram-Air Filter element and Air Filter Cover casting. If your original air filter cover has tune up and emissions specifications on it, save it for future reference.

3. Determine a path for the inlet air ducting from the air filter base forward to the vehicle's grille. Some vehicles have a plastic air inlet duct attached to the snorkel on the base of the air filter. This duct typically draws air through a plastic air inlet hood that is mounted either above, or to one side of the radiator. If this duct and hood are in place, proceed to step 4. If not, skip steps 4 thru 8 and proceed to step 9.

4. Disconnect the plastic factory air inlet duct at the air inlet hood. Remove the air inlet hood from the mounting bracket by twisting it until the four tabs line up with the slots in the bracket. **See Figure 3.**

FIGURE 3

TO REMOVE PLASTIC AIR INLET HOOD, TWIST HOOD SO TABS LINE UP WITH SLOTS IN BRACKET

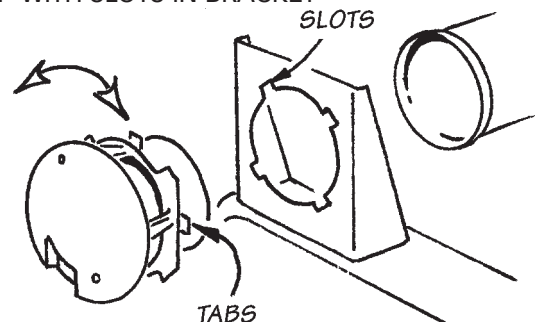
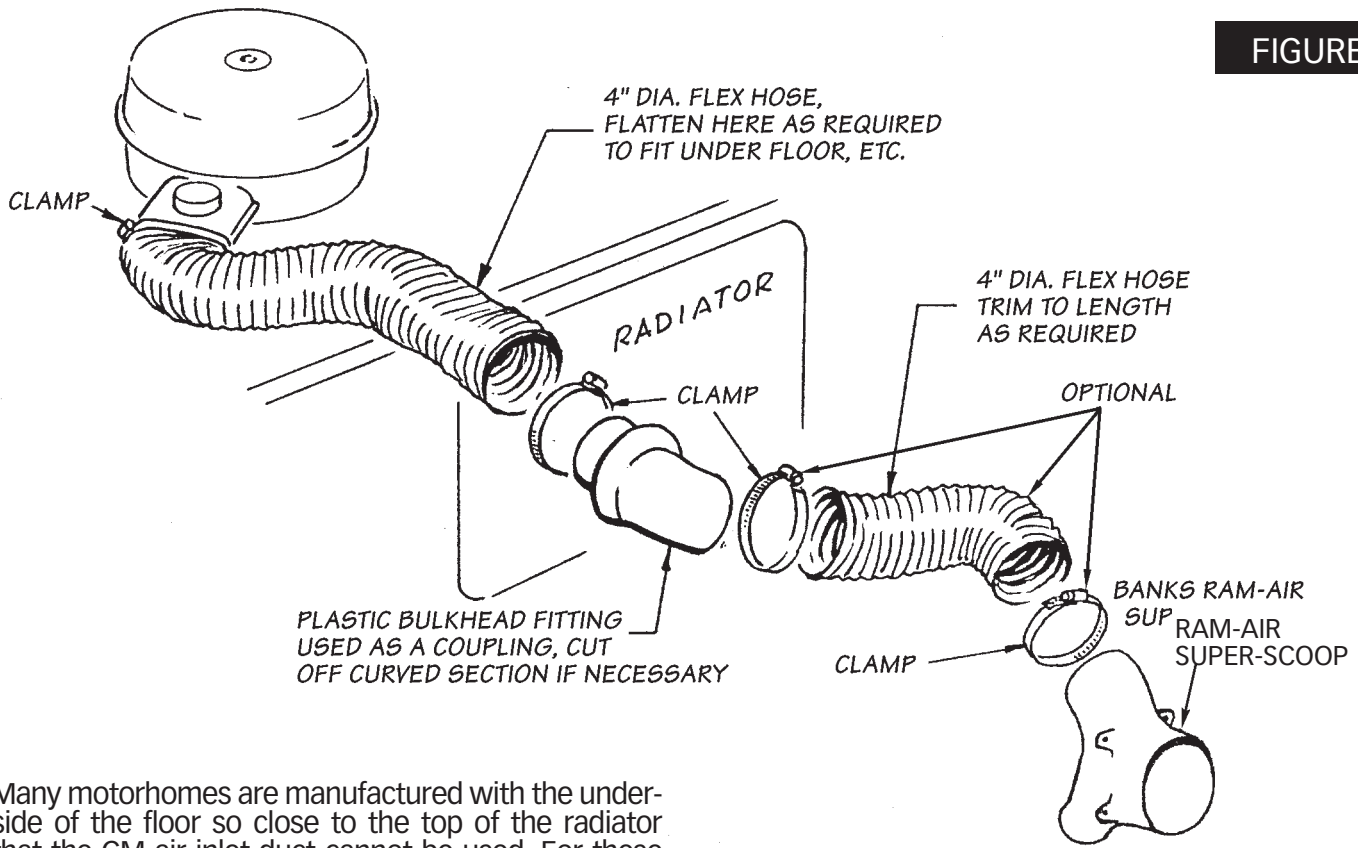

FIGURE 4



Many motorhomes are manufactured with the underside of the floor so close to the top of the radiator that the GM air inlet duct cannot be used. For these applications we have supplied additional 4" diameter flex hose that may be slightly flattened to fit between the radiator and the floor, provided the hose is at least 2 1/4" high after flattening. The plastic bulkhead fitting may be used as a coupling to join the two flex hoses together using two No. 64 hose clamps.

If your installation requires this procedure, substitute the instructions on this sheet for steps 5 thru 9 of the installation procedure. **See Figure 4.**

5. Insert the Banks plastic bulkhead fitting through the bracket from the back side. The bulkhead fitting may be used as is, or the curved portion may be cut off if this lines up better with the factory air inlet duct. **Figure 5** shows where to cut the bulkhead if the curved portion is to be removed.

6. Drill four 3/8" diameter holes through the air inlet hood bracket around the perimeter of the center hole. **See Figure 6.** If the bracket cannot be drilled while in place, it may be unbolted for drilling.

7. Slip the bulkhead fitting into the end of the factory air intake duct, and rotate the bulkhead fitting into the desired mounting position. Have someone hold the bulkhead fitting against the mounting bracket from the back side while you mark the centers of the four drilled hole locations. Drill four 1/8" diameter holes into the bulkhead fitting at these points.

8. Now bolt the bulkhead fitting to the bracket using four No. 6 x 1/2" sheet metal screws. Hook up the factory flex hose from the air filter base to the bulkhead fitting.

FIGURE 5

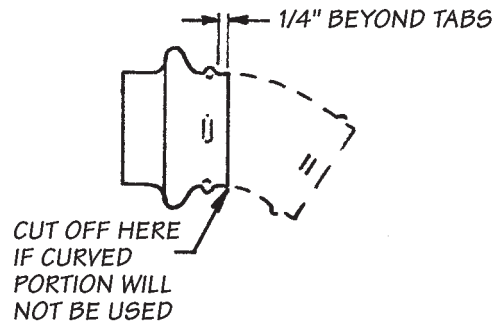
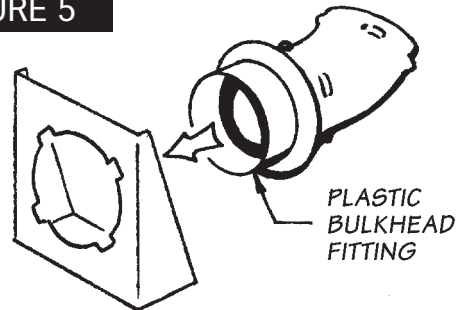

9. Determine a location for the Banks Super-Scoop™. It should be placed as low as possible directly behind the grille, with the air inlet opening pointing straight ahead. If the grille is at an angle, the Super-Scoop should be trimmed at an angle to place the air inlet opening against the back side of the grille with the centerline of the inlet opening horizontal. **See Figure 7.** Use heavy snips or a hack saw to trim the air inlet opening of the Super-Scoop.

FIGURE 6

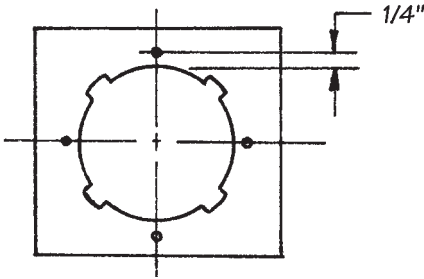
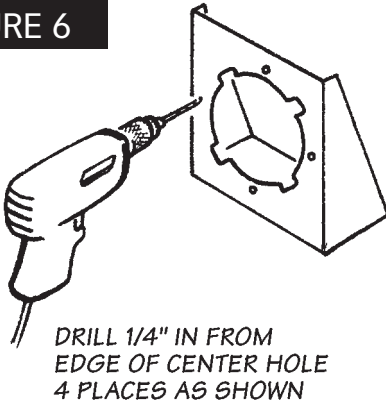

The height between the Super-Scoop and the air inlet hood should be as great as possible to prevent any rain water not eliminated by the air inductor's water drain hole from climbing up into the air filter. The curved outlet section of the Super-Scoop may be trimmed back if less bend is required to make a more streamlined hose routing. See Figure 7.

For motorhomes that do not have the plastic air inlet hood or any air inlet ducting connected to the snorkel on the air filter base, we have air ducting and clamps available for purchase. There must be at least a 2 1/4" high clearance between the floor of the coach and the top of the radiator bulkhead panel for the flex hose to pass through. If this clearance does not exist, it may be possible to mount the Super-Scoop somewhere else, such as in a wheelwell, etc. It should be located where it will receive the coolest air available, and be shielded from foreign materials such as flying stones and excess water spray.

FIGURE 7

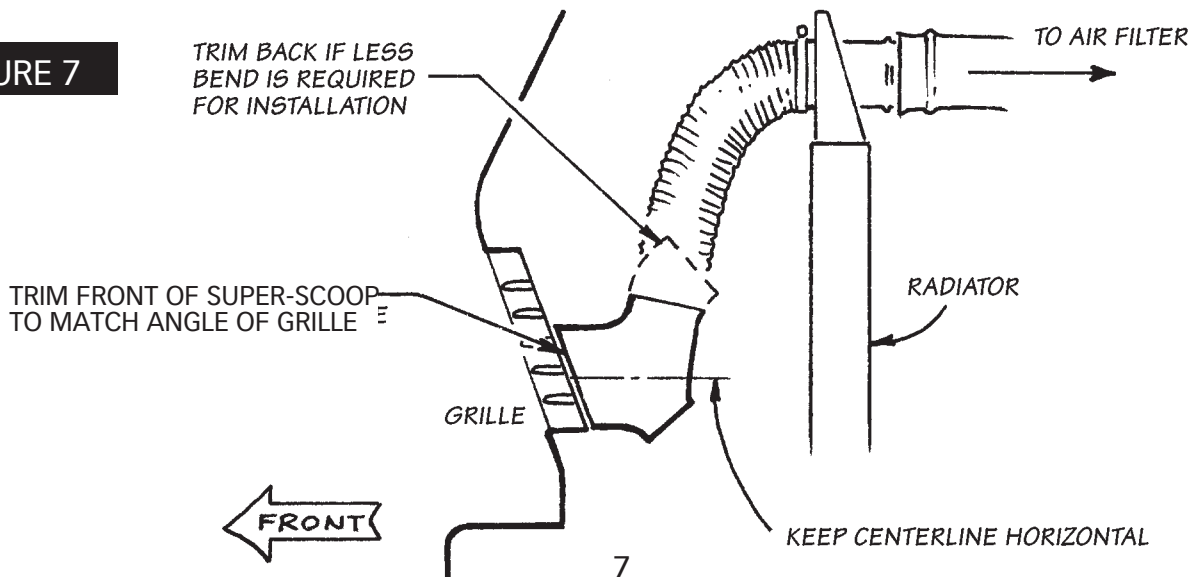

10. Once a location has been determined for the Super-Scoop, mount it using one of the following methods.

The Super-Scoop may be mounted by several means. If the grille consists of horizontal bars or a perforated metal screen heavy enough to support the Scoop, it may be secured using four 14" clear nylon cable ties, provided, slipped through the ears on the Super-Scoop and through the grille. See Figure 8.

An alternate method is to mount the Super-Scoop using the four perforated metal straps provided. These can be bent as required and attached to the Scoop ears with the 1/4-20 x 1/4 hex bolts, 1/4-20 nylock nuts and 3/8 O.D. x 5/16 I.D. flat washers provided. The opposite end of the straps may be attached to any convenient mounting points such as the gravel pan, grille brackets, etc. as required, with four No. 10 x 3/8" sheet metal screws provided. A combination of cable ties and straps may also be used.

11. Connect the bulkhead fitting to the Super-Scoop using the 4-inch diameter flex hose provided. Cut the hose to the desired length using a knife and diagonal cutting pliers. Secure with two No. 64 hose clamps. If your coach does not have the factory air inlet hood bracket, but you do have clearance to run the 4-inch flex hose forward of the radiator, join the air filter snorkel to the Super-Scoop with the piece of 4-inch diameter flex duct provided. Use the plastic bulkhead fitting as a coupling between the hoses, and trim off the curved section if desired. Attach the flex hoses with four No. 64 hose clamps. You may want to tie the plastic bulkhead fitting down to keep it in place. See Figure 4.

12. Raise front of vehicle on hoist or ramps.

NOTE: Figure 9 shows how ramps may be constructed for this purpose.

WARNING! Observe safety precautions regarding use of ramps and other lifting methods. See general instruction practices and cautions contained in Figure 9.

If the vehicle is supported by a hoist, the front wheels may be removed for further accessibility.

FIGURE 8

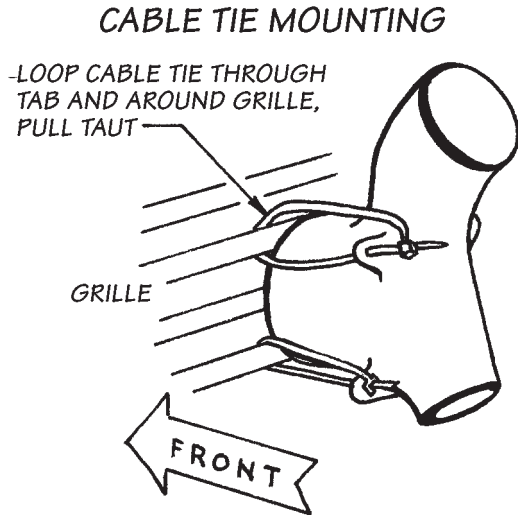

STRAP MOUNTING

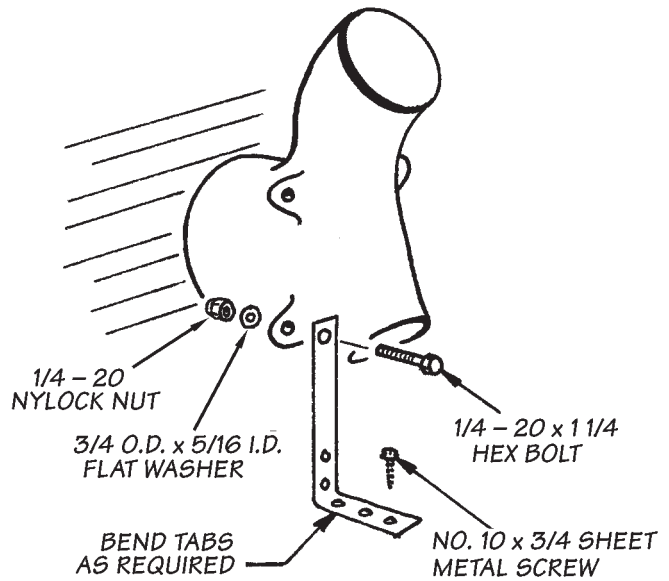

FIGURE 9

WARNING! READ CAUTIONS IN GENERAL INSTRUCTION SECTION CONCERNING WORKING UNDER MOTORHOMES ON JACKS OR SUPPORTS.

MOST MOTORHOME POWERPACK INSTALLATIONS WILL REQUIRE RAISING THE FRONT OF THE COACH TO INSTALL THE BANKS POWERPACK EXHAUST MANIFOLDS. A PAIR OF SUPPORT RAMPS MAY BE CONSTRUCTED AS SHOWN.

CAUTION! MAKE SURE THE COACH IS ON FIRM LEVEL GROUND WHEN USING THESE RAMPS. SLOWLY DRIVE UP THE RAMPS WHILE YOU HAVE SOMEONE GUIDE YOU TO KEEP THE VEHICLE CENTERED AS YOU GO AND TO LET YOU KNOW WHEN YOUR TIRES ARE IN POSITION ON TOP OF THE RAMPS. DO NOT GO UNDER THE COACH UNTIL YOU ARE SURE IT IS STABLE ON THE RAMPS, THE TRANSMISSION IS IN "PARK" AND THE HAND BRAKE IS SET. WE ALSO SUGGEST YOU PLACE A BLOCK BEHIND THE REAR TIRES AS AN ADDITIONAL SAFETY MEASURE.

4 x 4 BLOCK NAILED IN PLACE FOR A TIRE STOP

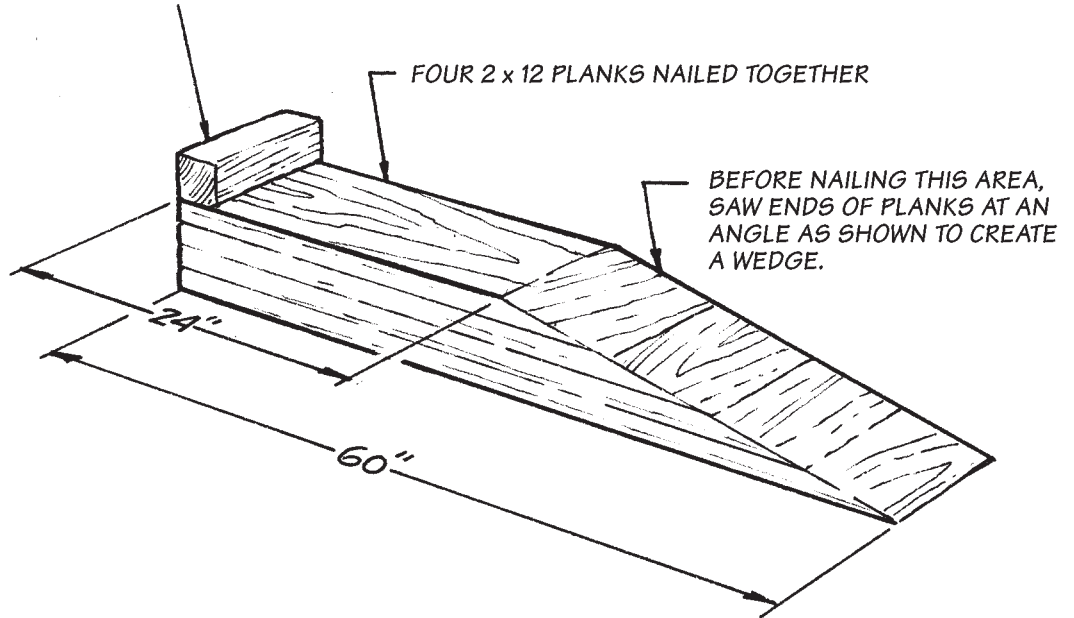

Remove the bolts attaching the rear of the inner fender panel to the chassis (behind driver's side front wheel). This panel may now be pulled outward to provide working room around the left side of the engine.

13. Disconnect both battery cables.
14. Remove spark plugs. Label plug wires for reinstallation. **See step 23.**
15. Disconnect and remove hot air tube (EFE) from heat stove on right exhaust manifold.
16. Starting from the rear and working forward, disconnect and remove the entire exhaust system, including the exhaust manifolds from the engine.
17. Remove air injection tube assembly from exhaust manifolds. Use of a flare-nut wrench, penetrating oil and heat may be required on stubborn pieces. Save the tube assembly for re-use.
18. Remove the short nozzle tubes from the exhaust manifolds. If any of these are stuck in place by carbon, rust, etc., they may be tapped out of the manifold with a hammer from the cylinder head side.

NOTE: Use care not to distort the ends of these tubes as they will be re-used and must slide through the ports on the new manifolds.

19. Install the starter heat shield on the starter motor as follows: Loosen the lower starter motor thru-bolt 3-4 turns. Make sure the outer solenoid coil bolt is snug. Place a $\frac{5}{16}$ " I.D. x $\frac{3}{4}$ " O.D. flat washer over the stud end of the upper starter motor thru-bolt. Hook the starter heat shield onto the end of the outer solenoid bolt and slide the front of the shield onto the two thru-bolts. The shield goes under the loosened head of the lower bolt and over the washer on the upper bolt. **See Figure 10.**

20. Tighten the lower starter motor thru bolt against the heat shield. Place a $\frac{5}{16}$ " I.D. x $\frac{3}{4}$ " O.D. flat washer and a $\frac{1}{4}$ -20 nylock nut on the stud end of the upper thru bolt, and tighten. Install a $\frac{1}{4}$ -20 nylock nut on the exposed end of the outer solenoid coil bolt and tighten. Make sure heat shield will not short against any wiring. **See Figure 11.**

21. Clean exhaust manifold flange surfaces on cylinder heads of any loose rust and carbon. Working from under the vehicle, guide the Banks exhaust manifolds up into place and bolt them to the cylinder heads. Use the original manifold bolts and spark plug heat shields. Short heat shields are used on the right front and left rear locations.

NOTE: Use a screwdriver handle, spark plug socket and extension, or similar tool as a pry bar in the heat shields to center them over the spark plug hole centerline, then reinstall spark plugs.

NOTE: Some air conditioner compressor brackets may have to be filed slightly to clear the top of the left hand manifold flange.

FIGURE 10

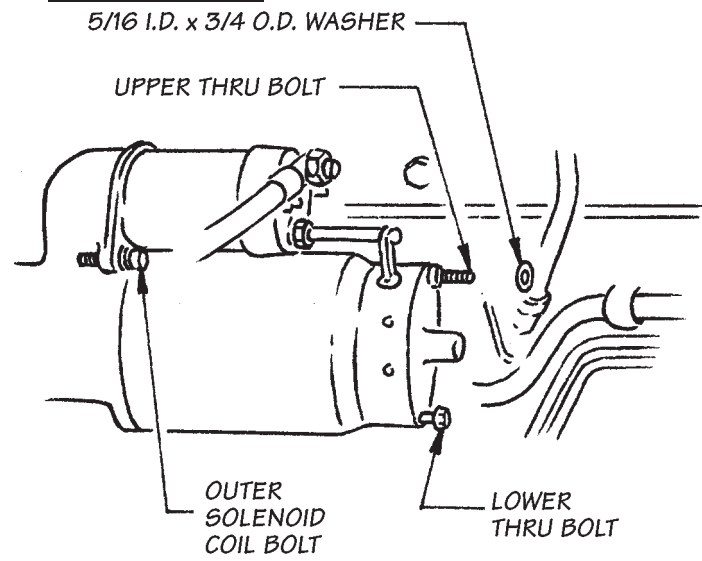

FIGURE 11

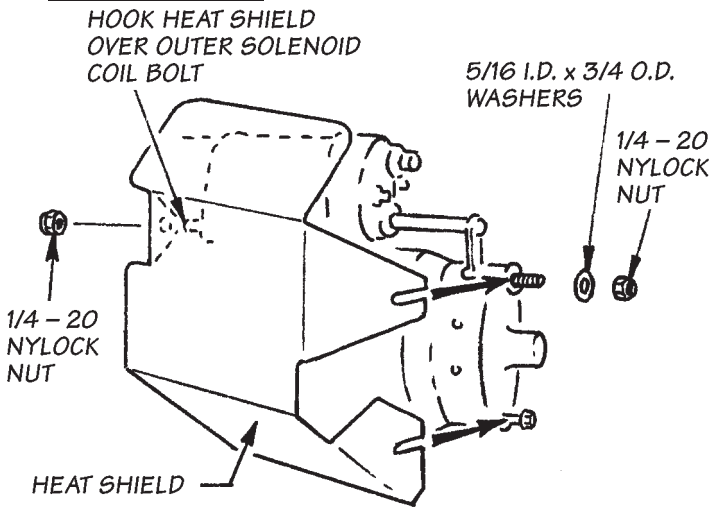
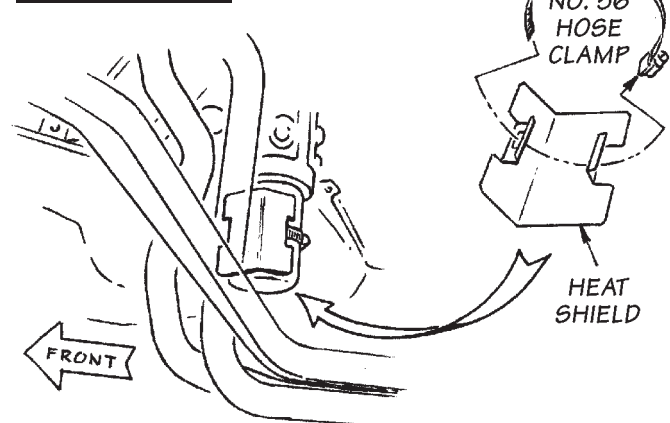

FIGURE 12



22. Reinstall the air injector nozzles and tube assemblies on the new exhaust manifolds. Hook up the hoses to the tube assemblies. Use anti-seize on the threads.

23. Reinstall the hot air tube from the front of the right exhaust manifold to the air cleaner inlet.

24. Reattach spark plug wires. Make sure wires are attached to the proper spark plugs. Engine firing order is 1-8-4-3-6-5-7-2, with 1, 3, 5 and 7 on the left (driver's) side, front to back, and 2, 4, 6 and 8 on the opposite side, front to back. Make sure plug wire boots are pushed on firmly for good electrical contact, and wires are routed as far away as possible from manifold pipes to prevent heat damage. If the condition of the spark plug wires look marginal, replace with a good quality silicone insulated suppression type wire set.

25. Open a number 56 hose clamp and thread it through the slots on the oil filter heat shield. See Figure 12. Position the heat shield on the oil filter to provide protection from the closest manifold pipe, then tighten clamp.

26. Install an exhaust "doughnut" seal in the right exhaust manifold outlet flange. Lightly tap the seal into place with a hammer until it seats.

27. Install three $\frac{3}{8}$ " x $2\frac{1}{4}$ " studs in the right exhaust manifold outlet flange. Two $\frac{3}{8}$ " coarse thread nuts jammed against each other on the outer stud threads may be used to wrench the studs into place. Use anti-seize compound on the threads.

28. Install three $\frac{3}{8}$ " x $2\frac{7}{8}$ " studs in the left exhaust manifold outlet flange. Use anti-seize compound on the threads.

29. Remove the old "doughnut" seal from the heat riser valve (EPR) if still attached, and replace with new seal provided. Lightly tap the seal into place to seat it.

30. Slide the heat riser valve into position on the studs of the left exhaust manifold outlet. Note that the actuating diaphragm faces up and to the left.

31. Remove the forwardmost exhaust pipe hanger from the right hand frame rail. Install the hanger extension bracket, provided, on the frame rail at this location. Use two $\frac{3}{8}$ -16 x 1" hex

FIGURE 13

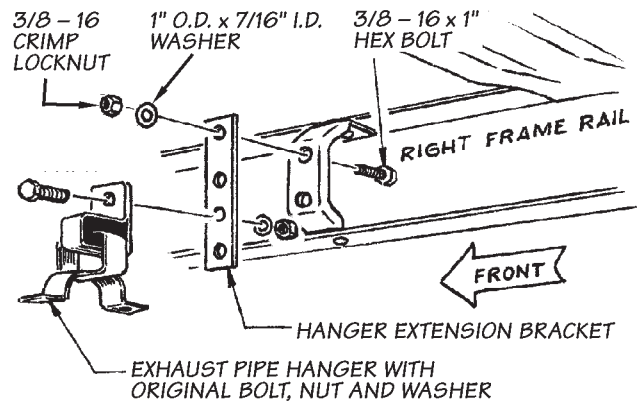

bolts, two 1" O.D. x $\frac{7}{16}$ " I.D. flat washers, and two $\frac{3}{8}$ -16 crimp locknuts to secure the extension. See Figure 13.

32. Reinstall the exhaust pipe hanger to the extension bracket using the original bolt, nut, and washer.

33. Install the Banks exhaust head pipes and muffler using the original nuts, washers, springs, etc. Use anti-seize on the threads. Position the pipes such that they can mount in the two forwardmost exhaust pipe hangers. Tighten all nuts, clamps, etc. See Figure 1.

34. Working from the muffler back, install the tail pipe sections most appropriate for your vehicle. Because of various chassis lengths and configurations, your tail pipe hangers may or may not line up properly for the tail pipe routing. We have provided three universal tail pipe hangers that may be attached to crossmembers, frame rails, etc. with the remaining $\frac{3}{8}$ -16 x 1" hex bolts, nuts, and washers. See Figure 1 for tail pipe assembly. Maintain $1\frac{1}{2}$ " of clearance to frame and body to prevent rattles and hot spots.

35. Install the chrome tailpipe extension tip and chrome tailpipe heat shield per Figure 1. Extension tip may be slid in or out over tailpipe until desired length is obtained for body width. Then clamp extension to tailpipe using 3" U-clamp.

FIGURE 14

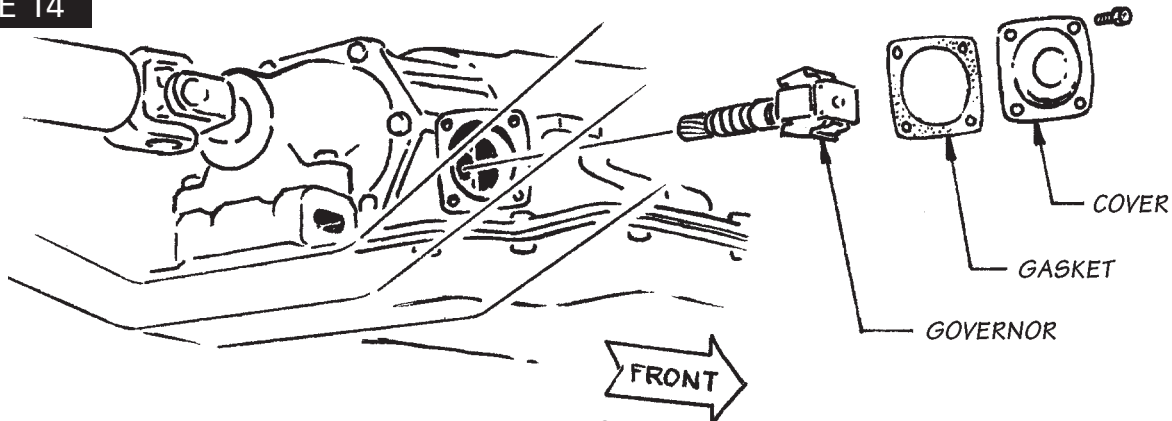
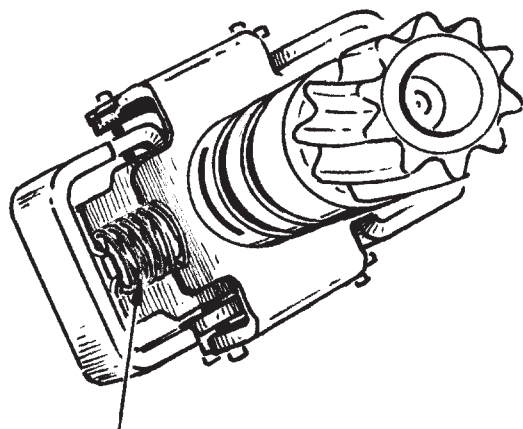

FIGURE 15



GOVERNOR SPRING (ONE OF TWO)

36. Install new vacuum hose, provided, from connection on heat riser (EPR) valve to metal vacuum line. Keep this hose as far as possible from exhaust system heat. Plastic cable ties are provided to attach the hose to crossmembers, etc.

37. If at all possible, route electrical wiring in the engine compartment as far away from exhaust manifold piping as you can, 8" or more is preferred. Plastic sleeve material over wire bundles is particularly sensitive to heat.

38. Reinstall inner fender panel and replace interior engine cover.

To fully utilize tuning the Banks PowerPack, the shift governor in the automatic transmission must be recalibrated to raise the vehicle's shift points in relation to vehicle speed. The shift points are changed by installing lighter springs in the transmission governor. Because there are a variety of coach body configurations, and therefore different vehicle weights, some experimentation will most likely have to be done to obtain the desired shift points.

Three different governor springs are provided in the Banks PowerPack. These springs are all lighter in tension than the factory springs, and are color coded orange, yellow, and green, from the lightest to the heaviest respectively. A good starting point for many vehicles is an orange-yellow combination.

If the vehicle has been recently driven, allow the transmission to cool before disassembling the governor, as hot transmission fluid can cause serious burns.

39. Place a drain pan under the governor cover, located at the rear of the transmission on the right hand side. Remove the four bolts attaching the governor cover and remove cover from transmission. It is normal for some fluid to be lost.

40. Remove the governor assembly by pulling it out and twisting it slightly counter clockwise. Keep the governor assembly as clean as possible while working on it. **See Figure 14.**

41. Using a small screwdriver or needlenose pliers, slightly compress the two springs under the governor flyweights, and remove them from the governor assembly. **See Figure 15.**

42. Select the desired pair of springs from those provided in the PowerPack kit. Install this pair of springs in the governor assembly. Make sure the ends of the springs pop over the raised buttons in the governor assembly. It does not matter which springs goes on which side.

43. Reinstall the governor assembly into the transmission case. Use the new gasket supplied when reinstalling the cover. **Tighten the cover bolts to approximately 15 ft.lbs.**

44. Replace any transmission fluid lost during disassembly.

45. Reconnect the battery cables. Start engine and listen for any exhaust leaks. Tighten bolts or clamps to correct leaks as required. When leaks are corrected, lower vehicle. Allow engine to warm up.

46. Check the transmission fluid level per instructions in owners manual, and adjust level as required.

47. Test drive vehicle. On a clear section of highway, accelerate at full throttle and note your shift points. In most applications, your 1-2 shift should occur at 32-34 MPH. (3900- 4100 RPM.), and the 2-3 shift at 55-57 MPH. (4000-4100 RPM.). If your coach has a tachometer, go by the tachometer reading.

It will probably take several tries to find the right combination of governor springs to achieve these shift points. Remember, lighter springs will raise the shift points, while heavier springs will lower them. Keep track of your testing changes.

CLEANING AND OILING THE BANKS RAM-AIR FILTER

Notification

The Banks Ram-Air Filter comes pre-oiled and no oiling is necessary for initial installation.

Use Banks Ram-Air Filter cleaning system (part # 90094), available from Gale Banks Engineering to service the Air Filter. Follow the instructions included with the cleaning system to clean and re-oil the Ram-Air Filter.

1. PRE-CLEANING

Tap the element to dislodge any large embedded dirt, then gently brush with a soft bristle brush. NOTE: If complete cleaning is not practical at this time, reoil the element and reinstall in your vehicle.

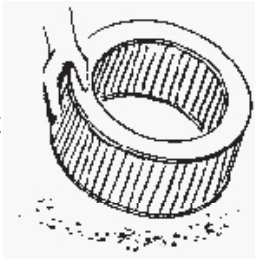

2. SPRAY-ON CLEANING

Spray Banks air-filter cleaner liberally onto the entire element and let soak for 10 minutes.

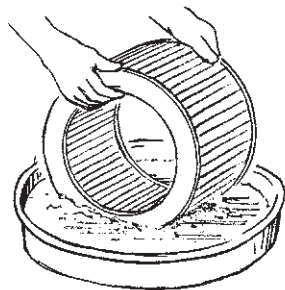

PAN CLEANING

Large air-filter elements can be rolled or soaked in a shallow pan of Banks air-filter cleaner. Remove immediately and let soak for approximately 10 minutes.

3. CLEANING HINTS

Use only Banks air-filter cleaner. NO gasoline cleaning, NO steam cleaning, NO caustic cleaning solutions, NO strong detergents, NO high-pressure car wash, NO parts cleaning solvents. Any of these NOS can cause harm to the cotton filter media plus SHRINK and HARDEN the rubber end cans

4. RINSE OFF

Rinse off the element with low-pressure water. Tap water is okay. Always flush from the clean side to dirty side. This removes the dirt and does not drive it into the filter.

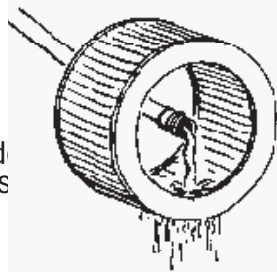

5. DRYING HINTS

Always dry naturally. After rinsing, shake off all excess water and let the element dry naturally. DO NOT USE COMPRESSED AIR – DO NOT USE OPEN FLAME – DO NOT USE HEAT DRYERS!

EXCESS HEAT WILL SHRINK THE COTTON FILTER MEDIA. COMPRESSED AIR WILL BLOW HOLES IN THE ELEMENT.

6. AEROSOL OILING

After cleaning air filter always reoil before using. Spray Banks Ram-Air filter oil down into each pleat with one pass per pleat. Wait 10 minutes and re-oil any white spots still showing.

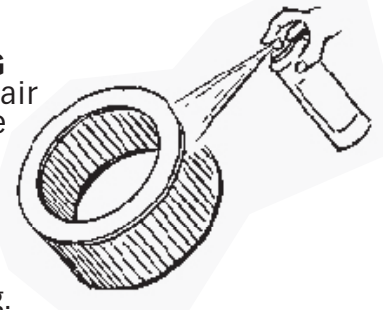

7. OILING HINTS

Never use a Banks Ram-Air filter without oil (the filter will not stop the dirt without the oil). Use only Banks Ram-Air filter oil. Banks air-filter oil is a compound of mineral and animal oil blended with special polymers to form a very efficient tack barrier. Red dye is added to show just where you have applied the oil. Eventually the red color will fade but the oil will remain and filter the air. NEVER USE Automatic Transmission Fluid. NEVER USE Motor Oil. NEVER USE Diesel Fuel. NEVER USE WD40, LPS, or other light-weight oils.

8. REINSTALL

Reinstall your Banks Ram-Air filter element with proper care. Make sure the element seats properly in the filter case. Install the cover making sure it's in the right position. Tighten all the nuts, bolts, screws or clips to factory specifications.

9. DO NOT DISCARD

Affix the "Do Not Discard" sticker to the filter case (included with every Banks replacement element). Make sure you put the sticker in a highly visible place to alert your mechanic not to discard.

10. PERFORMANCE HINTS

Service every 50-100,000 miles on street-driven applications. Service more often in offroad or heavy-dust conditions. If an air-filter restriction gauge is installed, then change the element when the air-filter restriction reaches 18"/H₂O.

CAUTION! Extremely fine dust from agriculture or offroad use will pull the oil from the element. Frequent reoiling of the element's clean side might be required. Completely service when practicable. For extra protection use an air-filter sealing grease on rubber ends of the element. Service only with Banks air-filter cleaner and Banks air-filter oil.