

banks

with Installation Instructions
Owner's Manual

Banks EconoMind Diesel Tuner

**2003-2007 5.9L Cummins ISB Class-A Motorhome
With Allison 3000MH 6-Speed Transmission**

THIS MANUAL IS FOR USE WITH SYSTEMS 63771, 63772, 63773, 63775, 63776

Gale Banks Engineering
546 Duggan Avenue • Azusa, CA 91702
(626) 969-9600 • Fax (626) 334-1743

Product Information & Sales: (888) 635-4565

bankspower.com

banks

Limitation of Warranty

Gale Banks Engineering Inc. (hereafter "**SELLER**"), gives Limited Warranty as to description, quality, merchantability, fitness for any particular purpose, productiveness, or any other matter of **SELLER**'s product sold herewith. The **SELLER** shall be in no way responsible for the product's open use and service and the **BUYER** hereby waives all rights except those expressly written herein. This Warranty shall not be extended or varied except by written instrument signed by **SELLER** and **BUYER**.

The Warranty is Limited to two (2) years from the date of sale and is limited solely to the Gale Banks Engineering parts contained within the products kit. Parts or devices outside the products kit, such as the Palm® Tungsten™ E2 PDA, are not covered under Gale Banks Engineering warranty. The warranty for the Palm® Tungsten™ E2 PDA is determined by the manufacturer's warranty terms and conditions, and limited to a period of 90 days from purchase. All products that are in question of Warranty must be returned shipping prepaid to the **SELLER** and must be accompanied by a dated proof of purchase receipt. All Warranty claims are subject to approval by Gale Banks Engineering Inc.

WARNING: The PDA may be susceptible to damage as a result of extended exposure to sunlight, heat or extreme cold. It is highly recommended that the PDA be removed from its mounting location if the vehicle will be subjected to high concentrations of sunlight, heat or cold for an extended period of time. Gale Banks Engineering is not responsible for damage to PDAs resulting from exposure conditions.

Under no circumstance shall the **SELLER** be liable for any labor charged or travel time incurred in diagnosis for defects, removal, or reinstallation of this product, or any other contingent expense.

Under no circumstances will the **SELLER** be liable for any damage or expenses incurred by reason of the use or sale of any such equipment.

In the event that the buyer does not agree with this agreement:

The buyer may promptly return this product, in a new and unused condition, with a dated proof-of-purchase, to the place-of-purchase within thirty (30) days from date-of-purchase for a full refund.

The installation of this product indicates that the buyer has read and understands this agreement and accepts its terms and conditions.

This product is only for motorhomes with 5.9L Cummins ISB engines and Allison 6-speed 3000MH transmissions.

There is a tag affixed to the transmission, on the driver's side. This will help you to determine if you have the correct transmission.

General Installation Practices

1. For ease of installation of your Banks EconoMind Diesel Tuner, familiarize yourself with the procedure by reading the entire manual before starting work. This manual contains 36 pages of copy, illustrations and parts listing. If any pages are missing from this manual please call Gale Banks Engineering immediately for a replacement.

2. The exploded illustrations provide only general guidance. Refer to each section diagram in this manual for proper instructions.

3. Throughout this manual, the left side of the vehicle refers to the driver's side, and the right side refers to the passenger's side of the vehicle.

4. Throughout this manual, pushers refers to the engine in the rear, and pullers refers to the engine in the front of the vehicle.

5. Disconnect the ground cable from the battery before beginning work. If there are two batteries, disconnect both.

6. Route and tie wires and hoses a minimum of 6 inches away from exhaust heat, moving parts and sharp edges. Clearance of 8 inches or more is recommended where possible.

7. During installation, keep the work area clean. If foreign debris is transferred to any Banks system component, clean it thoroughly before installing.

8. If you purchased the Banks PowerPDA[®], then the Palm Tungsten E2 will need to be charged for a minimum of 1-2 hours before the Banks software can be installed. Locate the supplied AC outlet wall charger, also located in your kit and plug the charging cord into the Tungsten E2. Please refer to the Banks PowerPDA Software & Installation Kit Owners Manual for additional instruction.

WARNING: The PDA may be susceptible to damage as a result of extended exposure to sunlight, heat or extreme cold. It is highly recommended that the PDA be removed from its mounting location if the vehicle will be subjected to high concentrations of sunlight, heat or cold for an extended period of time. Gale Banks Engineering is not responsible for damage to PDAs resulting from exposure conditions.

Tools Required:

- 1/4" or 3/8" drive ratchets with inch and metric sockets
- Inch and metric combination wrenches
- Pliers
- Wire cutters
- Wire strippers
- Drill motor
- 1/8" Unibit, 3/8" Unibit, 1/8", 3/16", 7/16" drill bits
- Tap handle
- 1/4" NPT tap
- Foot-pound torque wrenches
- Penetrating oil or light lubricant spray
- Heat gun

This product is only for motorhomes with 5.9L Cummins ISB engines and Allison 6-speed 3000MH transmissions.

There is a tag affixed to the transmission, on the driver's side. This will help you determine if you have the correct transmission.

Table of Contents

Introduction	5
Bill of Materials	6
Section 1	8
General Assembly	
Section 2	10
Motorhome General Assembly	
Section 3	16
Thermocouple Installation	
Section 4	19
Installation of Wiring Harness, Connections and EconoMind Tuner	
Section 5	23
Installation of Diagnostic Port Harness	
Section 6	24
Installation of EconoMind Tuner without PowerPDA or DynaFact Gauges	
Section 7	25
Installation of EconoMind Tuner with DynaFact Gauges	
Section 8	27
Installation of EconoMind Tuner with PowerPDA	
Section 9	28
Mounting the Docking Station and Connecting the Banks PowerPDA	
Section 10	30
Transmission Learning Procedures	
Section 11	31
Checking Engine Performance	
Section 12	32
Troubleshooting with EconoMind Tuner's LEDs	
Section 13	34
Troubleshooting EconoMind Tuner with PowerPDA	
Section 14	35
Removal of the EconoMind Tuner	

Introduction

Congratulations! You have just purchased one of the finest products on the market for enhancing the performance of your diesel engine. By installing the EconoMind Diesel Tuner, you will have the highest performance level available for your engine.

The Banks EconoMind Diesel Tuner with the Banks DynaFact gauges will keep you informed of your turbo's boost and engine's exhaust temperature while your EconoMind Diesel Tuner is set at maximum performance.

By choosing the Banks EconoMind Diesel Tuner with the PowerPDA option, you get six levels of power to pick from and real-time engine performance monitoring. All this on one easy to read color display!

The Banks PowerPDA is a versatile touch-screen interface to the EconoMind Tuner and your motorhome. With the push of a button, you can change power levels on-the-fly. You can choose power levels from stock, economy, all the way up to maximum power. It displays four engine functions at a time, two of which are user-selectable (over a dozen to choose from). It will record peak boost and EGT values. With the Banks PowerPDA, you can also scan and clear engine diagnostic codes. It gives you the endless functionality of a Palm Tungsten E2 PDA, and fits in a custom docking station. Please see the PowerPDA's owners manual for more information.

Bill of Materials

	Part Number	Description
1	61007	SD CARD, 64MB, PROGRAMMED
2	61009	UNIVERSAL MOUNT KIT, POWERPDA
3	62002	CABLE TIE, BLACK, 11"
4	62010	CABLE TIE, BLACK, 7"
5	62564	HARNESS, 9-PIN DIAGNOSTIC PORT, Tuner
6	62565	Y-SPLITTER, Tuner
7	62566	HARNESS, CAB, Tuner
8	62567	CABLE, PDA INTERFACE, Tuner
9	62568	EXTENSION HARNESS, Tuner
10	62569	JUMPER HARNESS, L6, Tuner
11	63042	EGT SENSOR
12	63062	EGT SENSOR, ELECTRIC
13	63770	MODULE, EconoMind Tuner
14	64506	GAUGE ASSEMBLY, DYNAFACT ELECTRIC
15	90045	ANTI SEIZE, 5 GRAMS
16	93033	GASKET, TURBO INLET
17	96010	UROCAL, BANKS POWER, LARGE
18	96392	PRODUCT REGISTRATION CARD
19	96420	OWNERS MANUAL, POWERPACK
20	96503	WARRANTY STATEMENT
21	96802	QUICK REFERENCE CARD, POWERPDA
22	91835	WASHER, SAE FLAT, #10
23	91910	NUT, NYLOCK, #10-32
24	91869	BOLT, HEX HEAD, #10-32 x 1.5"
25	91840	SHEET METAL SCREW, SLOTTED HEX HEAD #10-16 x 3/4"

	Kits:				
	63771 w/o PDA & Gauges All	63772 w/Gauges Pusher	63773 w/PDA Pusher	63775 w/Gauges Puller	63776 w/PDA Puller
1			1		1
2			1		1
3	15	25	25	15	15
4		5	5	5	5
5	1	1	1	1	1
6		1	1	1	1
7		1	1	1	1
8			1		1
9		1	1		
10	1	1		1	
11	1	1	1	1	1
12	1	1	1	1	1
13	1	1	1	1	1
14		1		1	
15	1	1	1	1	1
16	1	1	1	1	1
17	3	3	3	3	3
18	1	1	1	1	1
19	1	1	1	1	1
20	1	1	1	1	1
21			1		1
22	10	10	10	10	10
23	5	5	5	5	5
24	5	5	5	5	5
25	5	5	5	5	5

Section 1

General Assembly- Figures 1-6

1) Banks EconoMind Diesel Tuner

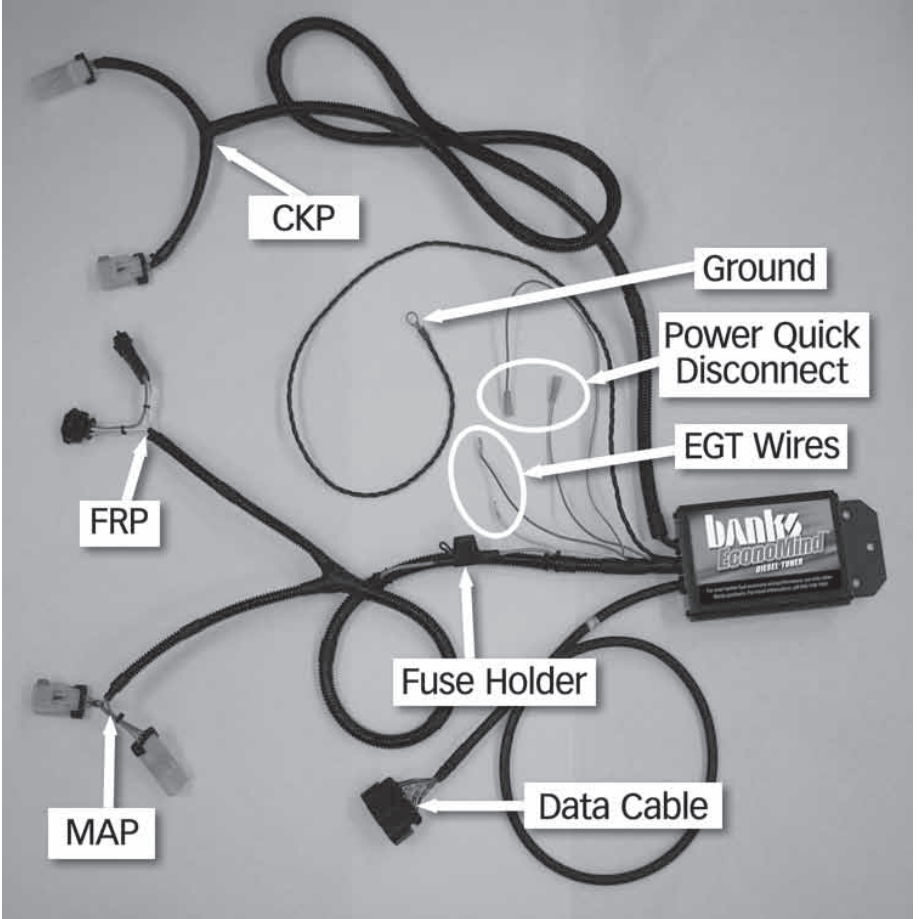

2) EGT Leadwire, Turbo Gasket, EGT Adapter, EGT Sensor

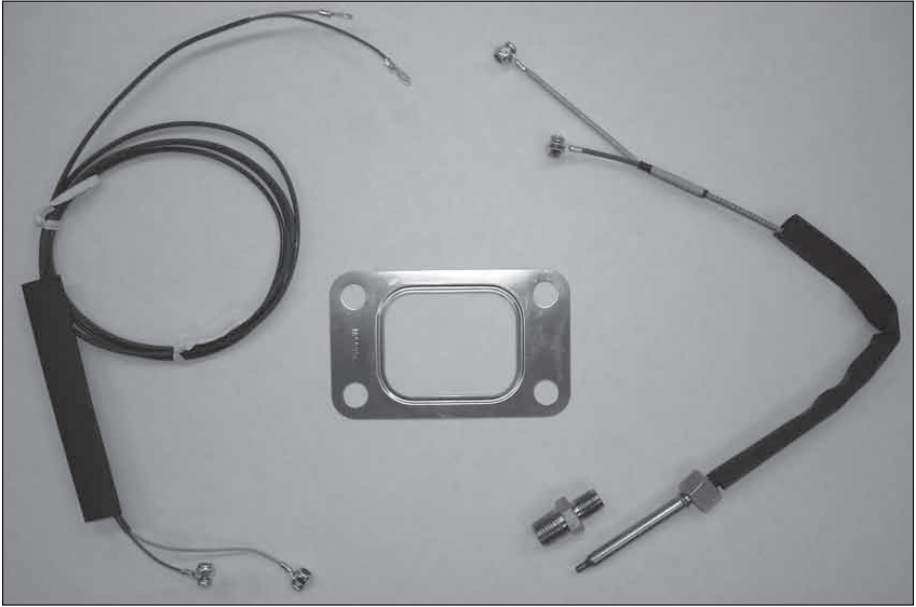

3) Diagnostic Port Harness



4) Extension Harness



5) Y-splitter, PDA Cable, Jumper Harness



6) Cab Harness



Section 2

Motorhome General Assembly- Figures 7-12

7) 63771 Pusher w/o gauges or PDA

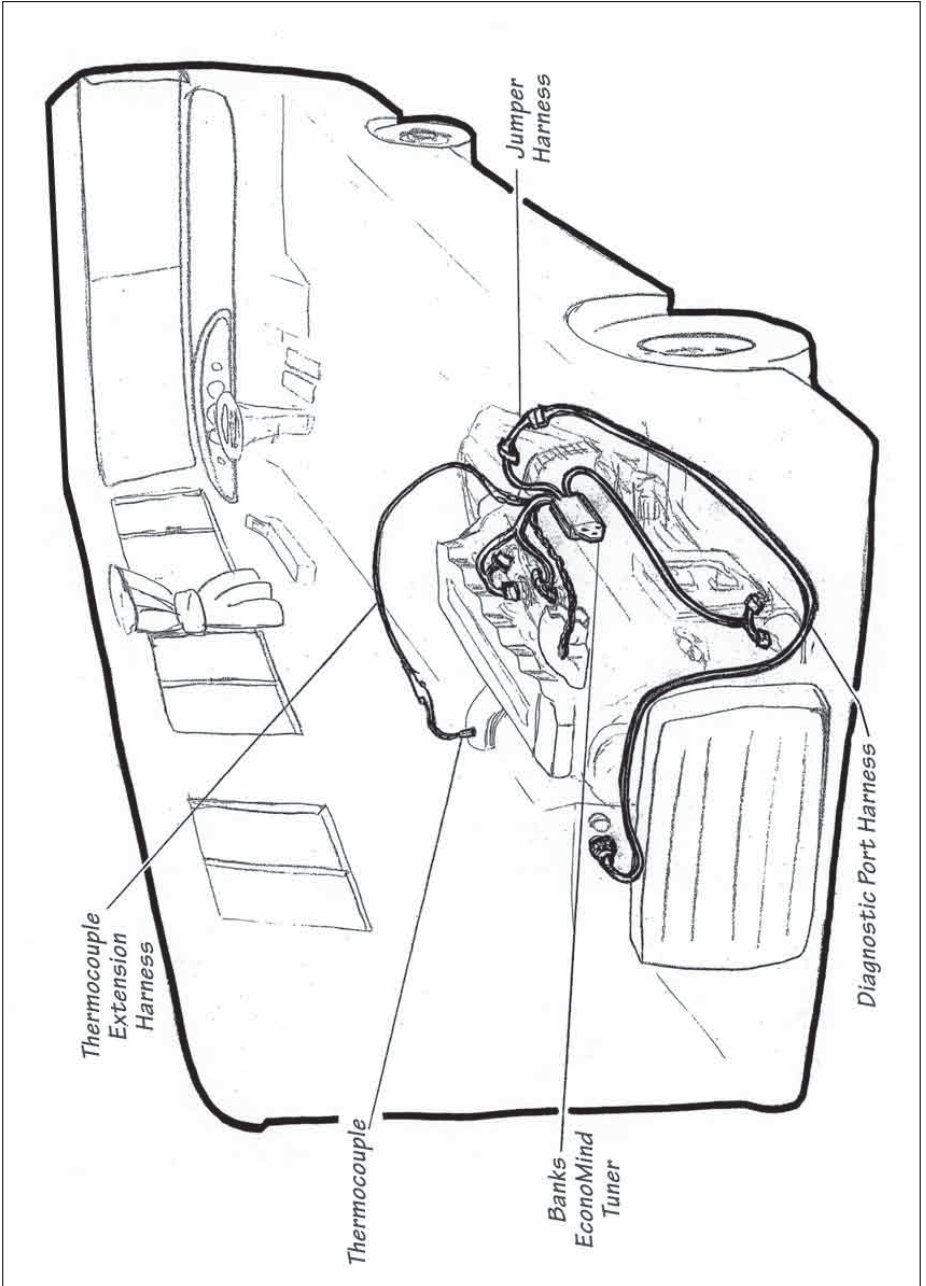

8) 63771 Puller w/o gauges or PDA

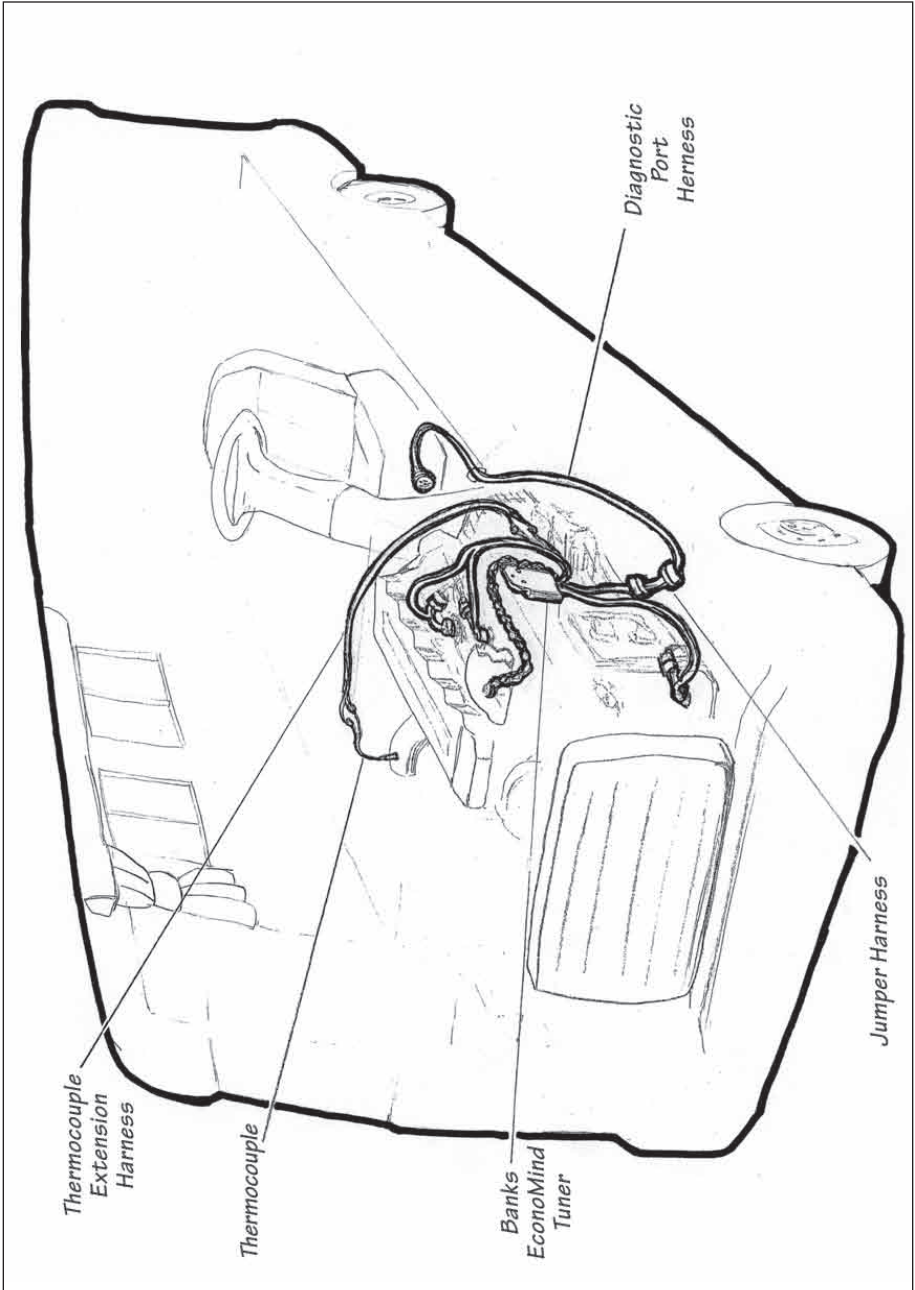

9) 63772 Pusher w/gauges

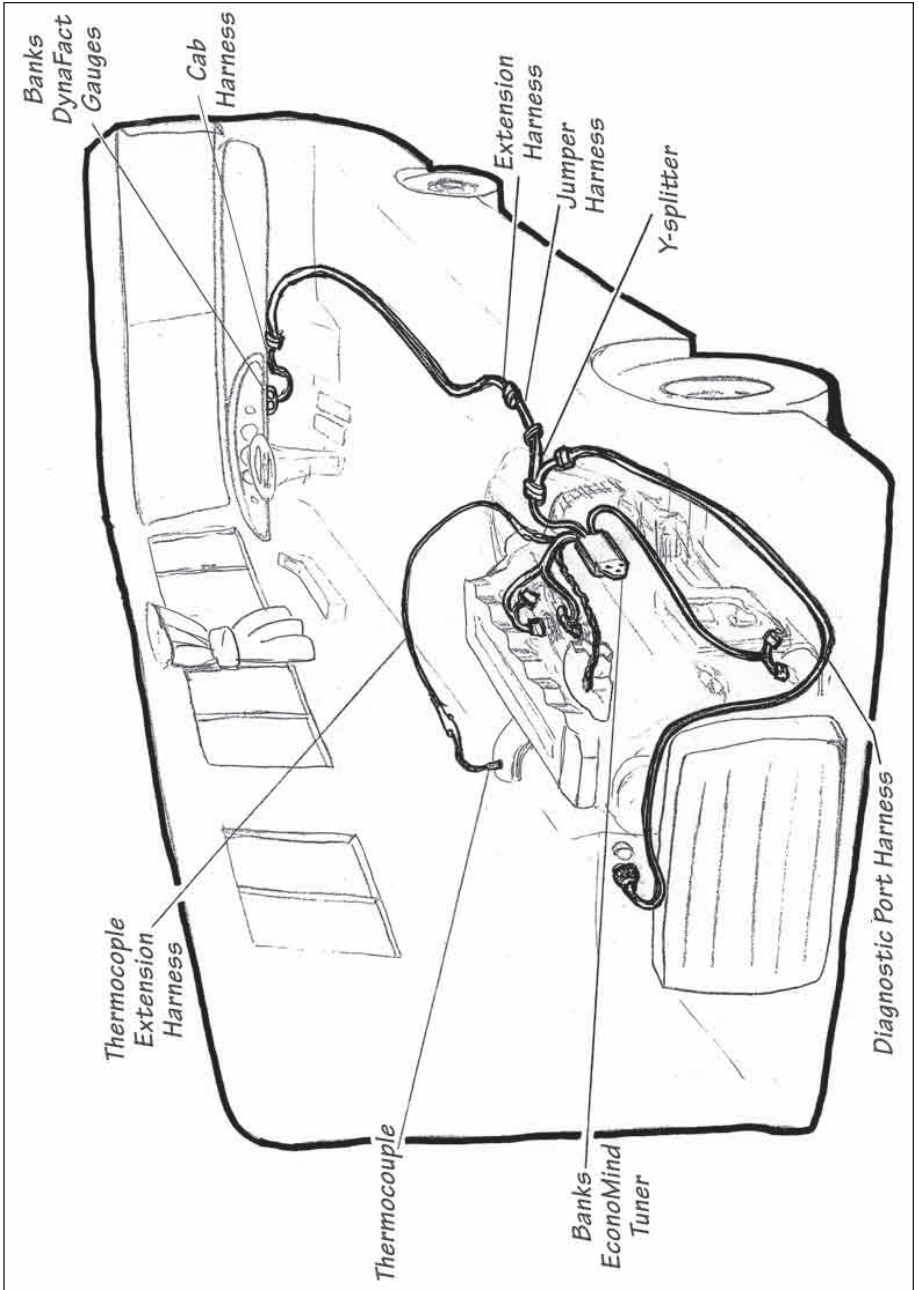

10) 63775 Puller w/gauges

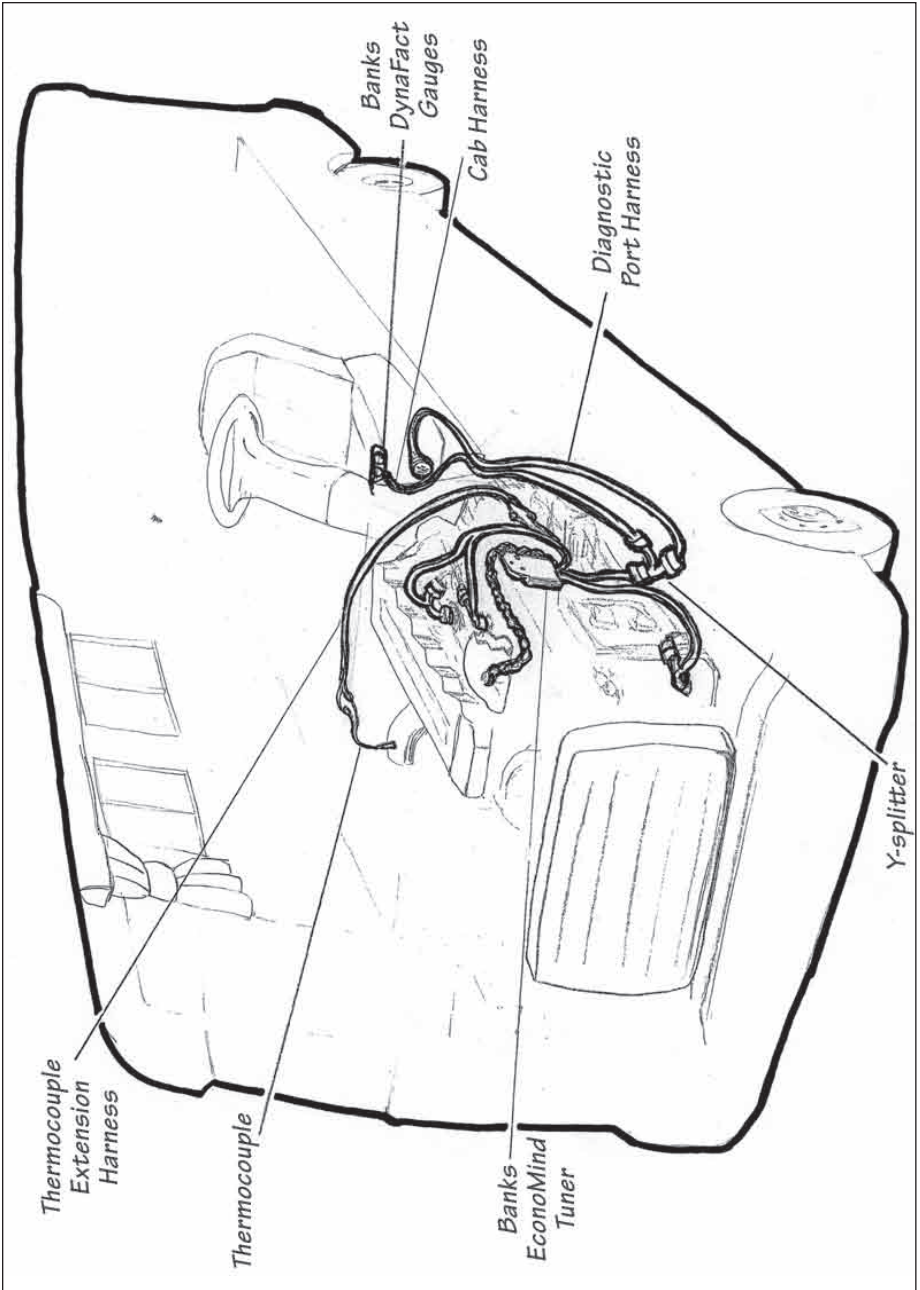

11) 63773 Pusher w/PDA

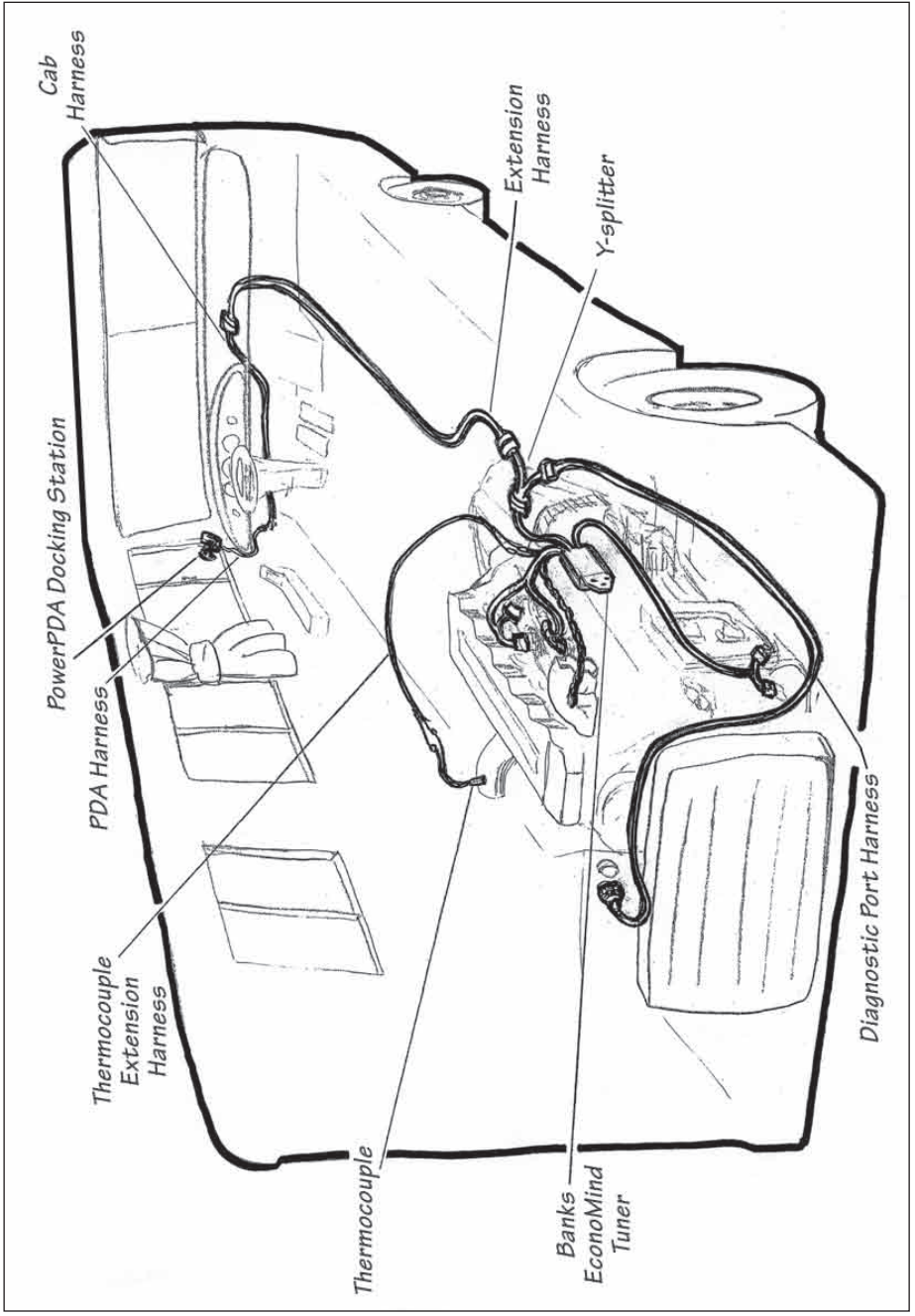

12) 63776 Puller w/PDA

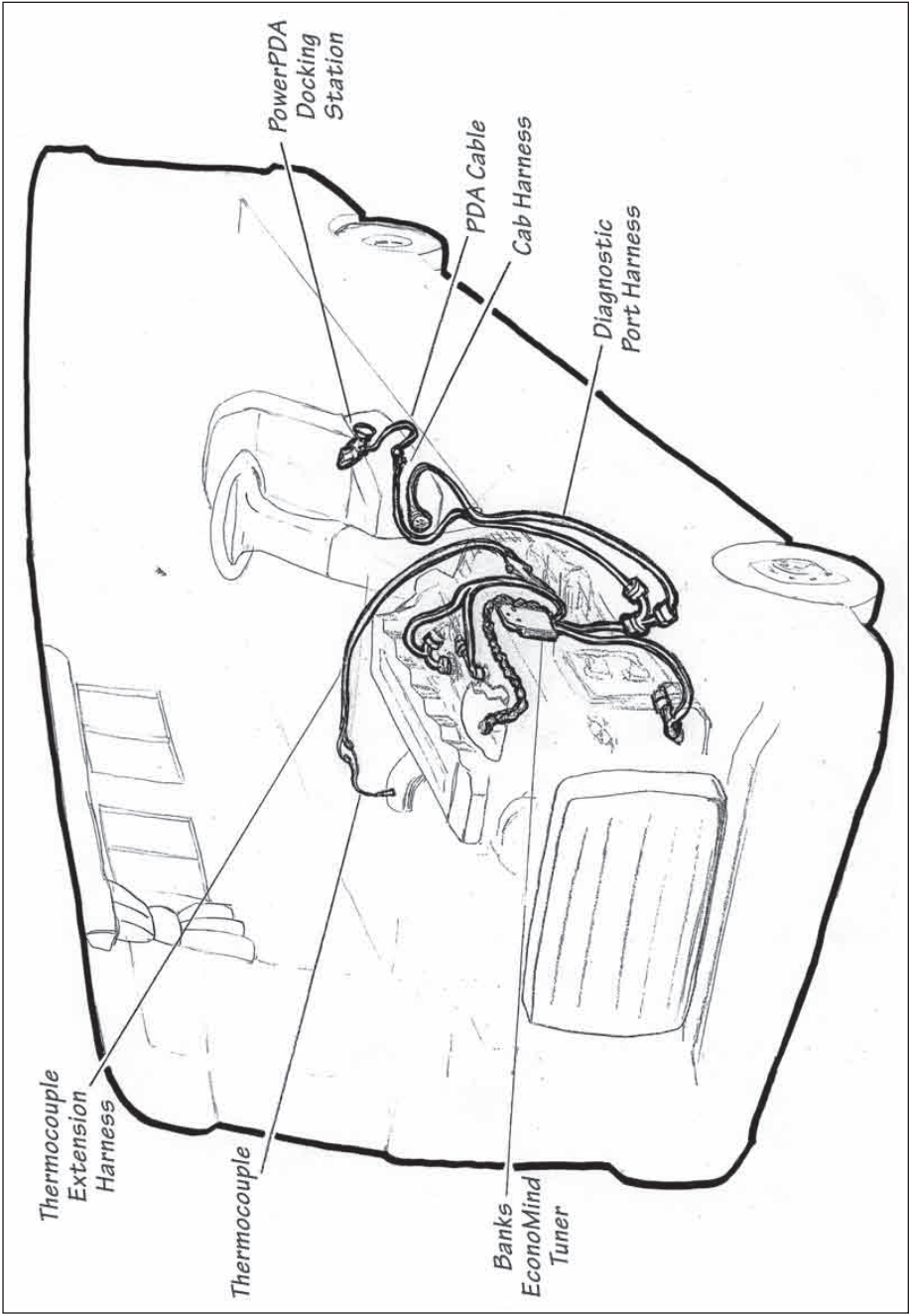

Section 3

Thermocouple Installation

1. Locate and identify the parts in your kit. Make sure that all the parts match up to the Bill of Materials list before starting.
2. Use caution when working in the engine compartment. Make sure the engine has been OFF for several hours and cool.
3. The exhaust gas temperature (EGT) sensor monitors the temperature of the exhaust entering the turbocharger turbine housing. Installation requires that the exhaust manifold be drilled near the outlet of the manifold adjacent to the turbine housing. For this reason it is essential that the turbocharger be removed from the exhaust manifold, or engine in order to keep out any metal chips from drilling that could cause turbine blade damage.

The Cummins ISB engine uses a divided exhaust manifold and turbocharger. The EGT sensor must be installed to sample exhaust temperature in one of the two exhaust passages. Typically the exhaust temperature will not differ appreciably between the two passages. It is recommended installing the sensor in the rear manifold passage to simplify routing the sensor wiring.

4. Locate the exhaust manifold where the EGT sensor is to be installed. Depending on the year and type of turbo your 5.9L Cummins engine is equipped with, it may be necessary to remove the EGR pipe to gain access to the exhaust manifold. See **Figure 13**.
5. Loosen the turbo's intake and exhaust tube clamps.

Figure 13

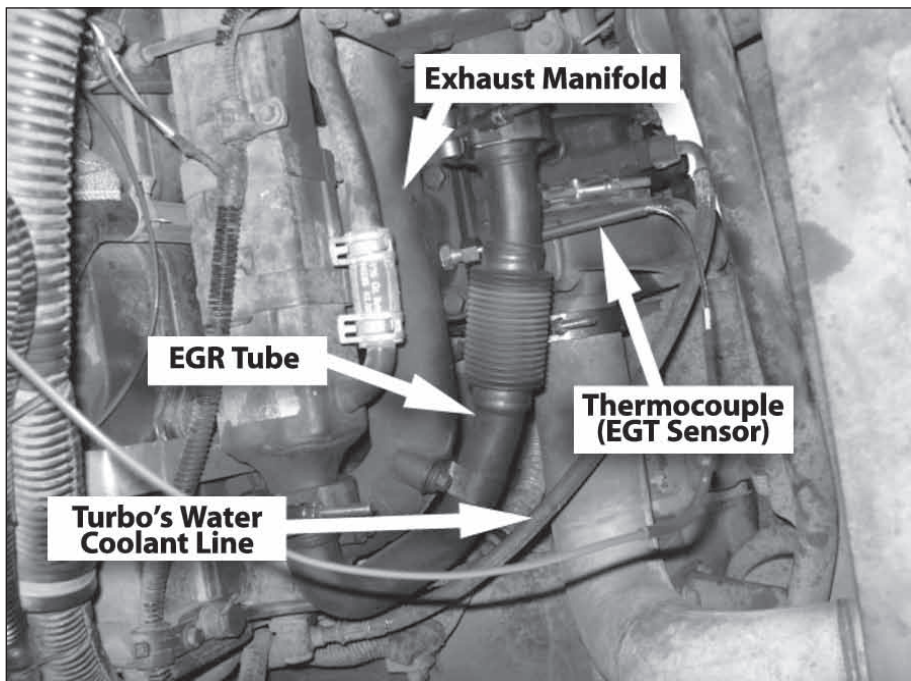

6. Spray the turbo flange bolts with penetrating oil to ease their removal. Loosen or remove the turbo flange bolts. Separate the turbo from the manifold.

7. Stuff a rag into the turbo flange opening to prevent chips and debris from falling into the turbo while drilling and tapping.

Note: It may be necessary to create a 4"x 5" piece of cardboard to slide between the turbo flange and the exhaust manifold flange.

CAUTION: Anytime the turbocharger is removed from the engine, take care that no foreign objects enter any of the turbocharger connections on the engine or the turbocharger. Foreign objects entering air, exhaust, or oil connections may cause major damage to the engine and/or turbocharger and is not covered under any warranty.

8. Use a center punch to mark the left side of the exhaust manifold as indicated in **Figure 14**. This will help prevent the drill bit from "walking" away from the location that is being drilled.

Optional: Use a smaller (less than 7/16") drill bit or Unibit to drill a pilot hole.

9. Drill through the exhaust manifold using a 7/16" drill bit, keeping the drill perpendicular to the manifold surface.

10. Tap the drilled hole with a 1/4" NPT pipe tap. Apply anti-seize to the EGT sensor adapter's threads being installed in the manifold. Install the EGT sensor adapter. With the use of an air gun, blow all the chips out.

11. Apply anti-seize to the threads of the EGT sensor adapter before threading the EGT sensor into the adapter. Install the EGT sensor into the adapter.

12. Carefully remove rag or cardboard. Do not allow any chips or debris to fall into the turbo as this could cause damage.

13. Install the new turbo inlet gasket from your kit. Reinstall the manifold/turbo flange bolts and tighten.

14. If applicable, reinstall the EGR pipe.

-END SECTION 3-

Figure 14

DRILL AND TAP 1/4 NPT PORT IN REAR
PASSAGE OF EXHAUST MANIFOLD OUTLET

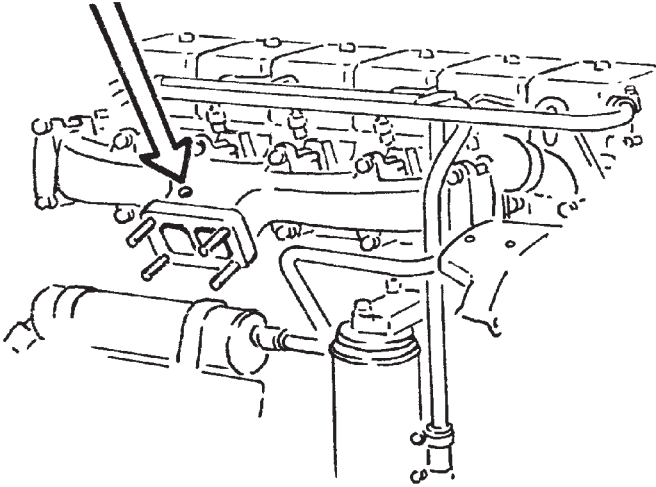

LOCATE PORT 3/4 INCH BEHIND FLANGE, CENTERED
OVER REAR EXHAUST MANIFOLD PASSAGE

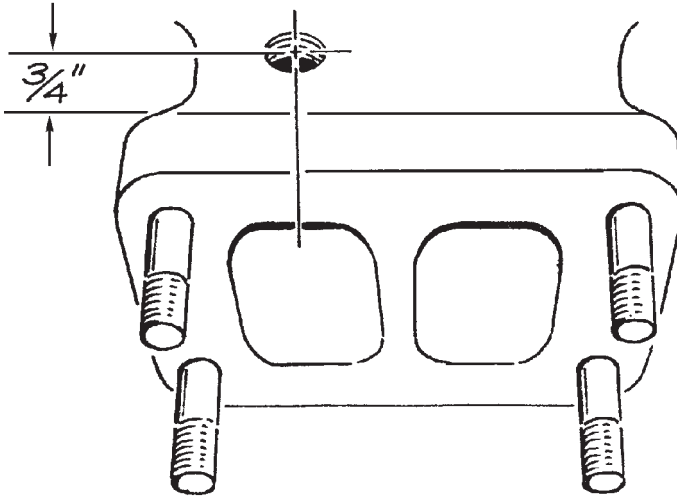

Section 4

Installation of Wiring Harness, Connections and EconoMind Tuner

1. Locate the EconoMind Tuner from your kit and lay out the harness. There may be differences between motorhome chassis and coach body builders so it is good to plan ahead and lay out your harness and locate a suitable mounting location.

2. Locate the crankshaft position (CKP) sensor on the engine. It is usually located at the bottom edge of the engine, near the crankshaft damper and engine belt(s) (**Figure 15**).

Note: There is a locking tab on both the Banks and factory female connectors. It may be necessary to unlock the tab prior to removal of the factory female CKP connector by sliding it to the side.

Push and hold the locking clip while disconnecting the factory (female) CKP connector and connect it to the Banks (male) CKP sensor connector. Connect

the Banks (female) CKP sensor connector to the factory sensor. Push in the locking tabs. Use the supplied wire ties to secure the Banks wiring to the factory installed wiring harness.

3. Locate the manifold absolute pressure (MAP) sensor installed at the top of the engine (**Figure 16**). Push and hold the locking clip while disconnecting the factory MAP sensor connector and connect it to the Banks (male) MAP sensor connector. Connect the Banks (female) MAP sensor connector to the factory sensor. Push in the locking tabs.

Note: There is a locking tab on both the Banks and factory female connectors. It may be necessary to unlock the tab prior to removal of the factory female CKP connector by sliding it to the side.

Figure 15

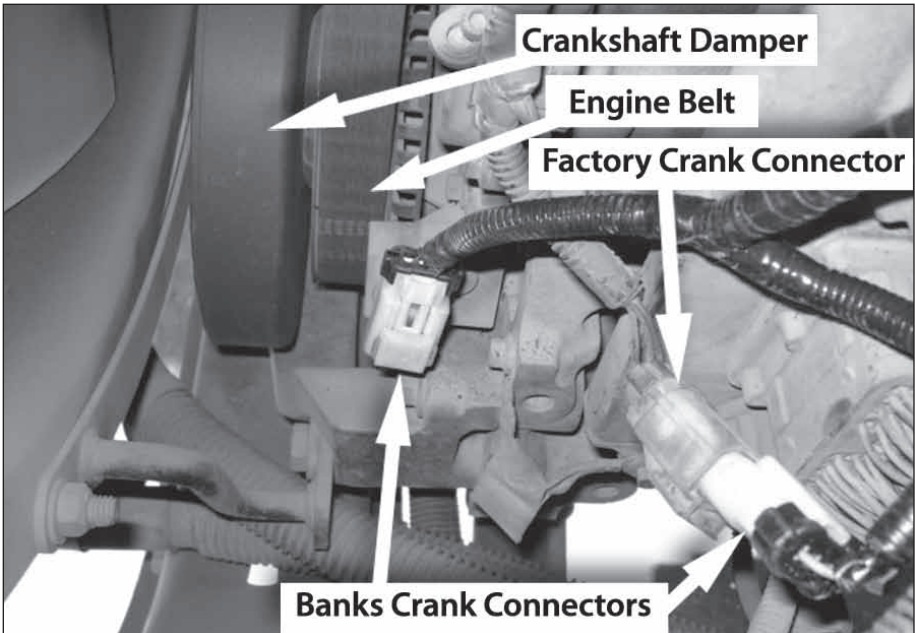
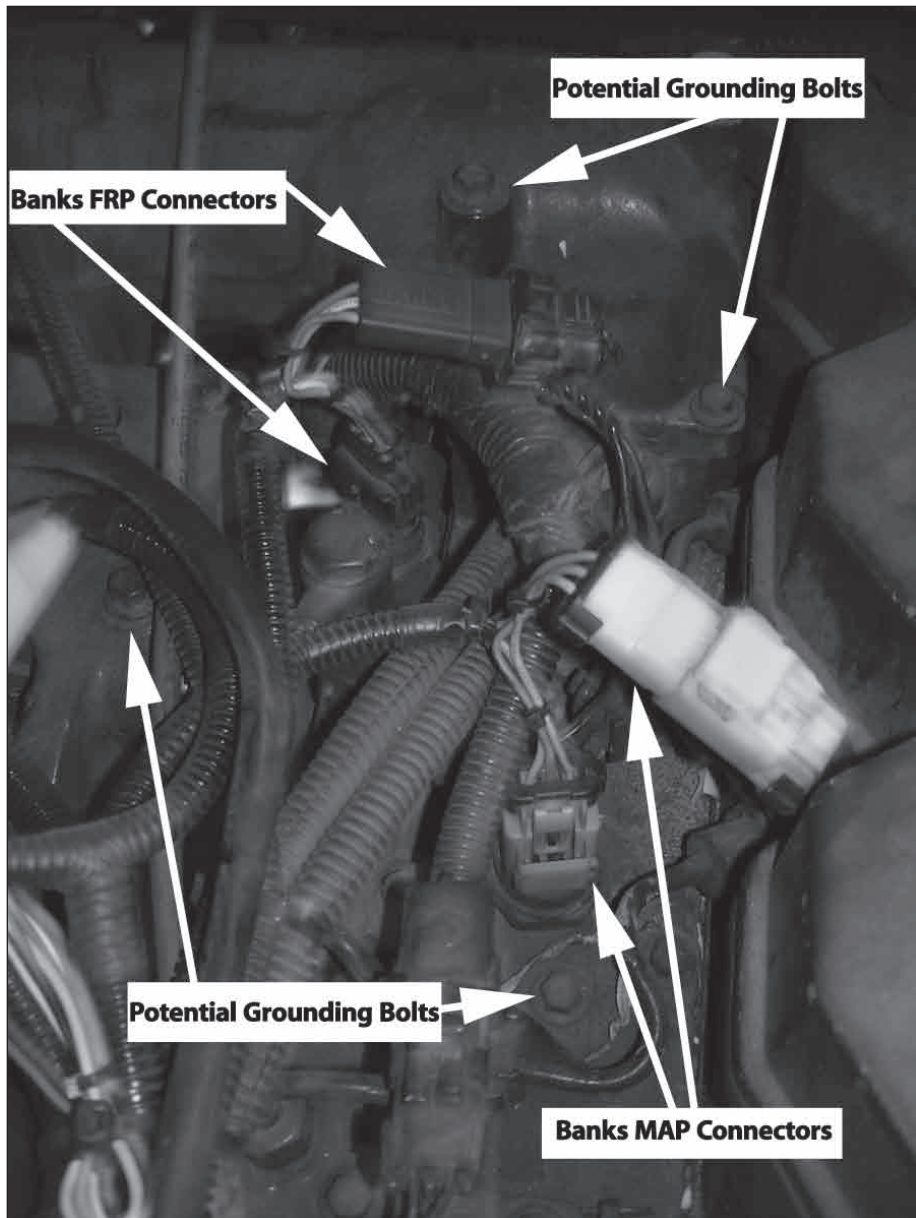

Figure 16



4. Locate the fuel rail pressure (FRP) sensor installed at the top of the engine near the MAP sensor. See **Figure 16**. Remove the factory FRP sensor connector by pressing and holding the locking clip while disconnecting it from the FRP sensor. Connect it to the Banks (male) FRP connector. Connect the Banks (female) FRP connector to the factory sensor.

5. Make sure each connector is securely fastened and locked. Use the supplied cable ties to secure the Banks wiring to the factory installed wiring harness. Make sure that the wiring harness is clear of hot or moving parts.

6. Locate a suitable location for the EconoMind Tuner. See **Figure 17** for an example. Mounting the Tuner on the wall of the engine compartment is ideal. Make sure that it is in a location that is away from heat, and clear of water and debris from the road.

*Note: The Tuner must be mounted so that it's LEDs are easily read. The LEDs let you know if the Tuner is working properly and provide error codes if there is a problem (**Figure 18**).*

7. Drilling holes in the coach bodywork may be required. Make sure to find a safe place to drill and know what is on the other side of the drilling area. Do not drill through any wires or electrical equipment. Drill $\frac{1}{8}$ " holes, using the Tuner's brackets as a template. Use the supplied sheet metal screws to secure the EconoMind to the coach body.

Note: Bolts, Nylock nuts, and flat washers are provided for coaches that have fiberglass paneling around the engine compartment. You will have to drill a hole through the fiberglass with a $\frac{3}{16}$ " or slightly larger drill bit. Slide a washer on each bolt before passing the bolts through the paneling and into the Tuner's brackets. Slide on a flat washer and screw on a nut to each bolt. Be careful not to tighten the

nut too tightly, as this can crack the fiberglass.

8. Attach the EGT sensor wires to the EconoMind's EGT ring terminals with the supplied hardware.

Note: Depending on the Tuner's location, it may be necessary to use the supplied EGT Leadwire.

Connect the YELLOW and RED wires of the Tuner to the corresponding ring terminals on the EGT sensor. Slide the heat shrink tubing over the exposed terminals and use a heat gun, hair dryer, or other suitable heat source to shrink the tubing.

9. Find a suitable bolt on the engine block to attach the black ground wire to. See **Figure 16** for some examples. Make sure to clean the area of any grease, oil, or dirt so there will be a good connection. Remove the bolt and slide it through the ground wire's ring terminal. Re-attach bolt.

10. Connect the EconoMind's power quick disconnect terminals together. The power quick disconnects are shown in **Figure 1**. Quick disconnect terminals are for possible future options.

-END SECTION 4-

Figure 17



Figure 18

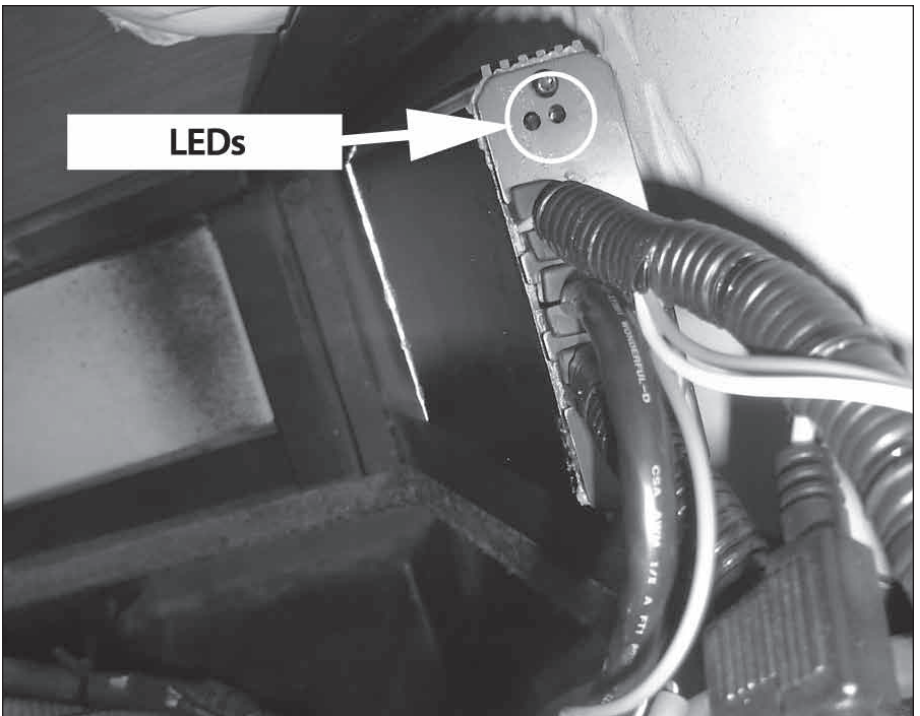

Section 5

Installation of Diagnostic Harness

1. Locate the Diagnostic Port Harness in your kit. Locate the round diagnostic port in your coach. The diagnostic port is located either:

a) Pushers- Inside the engine compartment or to the rear of the engine, accessible from the outside.

b) Pullers- Inside the coach, under the dash or in the engine compartment, accessible from the outside.

2. Remove the protective cap from the diagnostic port. Connect the Diagnostic Port Harness to the vehicle's diagnostic port. The Harness' connector is keyed, so it can only go on one way. The Harness' locking ring may have to be rotated to allow the connector to seat all the way into position. Turn the Harness' connector locking ring clockwise (to the right) until you feel it lock. There may be some resistance when rotating the locking ring into the locked position. Make certain the connector is locked and secured. Install the Banks' Protective Cover to the stock protective cap and twist them until they lock. This will help keep dirt and debris out of the caps.

Note: Depending on the diagnostic port's location, there may or may not be a protective cap.

-END SECTION 5-

Section 6

Installation of EconoMind Tuner without PowerPDA or DynaFact Gauges

If installing gauges, skip to **Section 7**.

If installing PDA, skip to **Section 8**.

DynaFact gauges are a useful tool to monitor vehicle performance. There is a turbo boost gauge and an EGT gauge that will measure exhaust temperatures.

1. Run the Diagnostic Port Harness to the Tuner Harness. Use the Jumper Harness to connect the EconoMind and the Diagnostic Port Harnesses together. You should feel the connectors lock together. Secure the Harnesses away from hot and/or moving engine components with cable ties.

2. Reconnect the battery ground cable(s).

3. Double check everything to make sure it is securely fastened and it is not near any hot or moving parts before starting engine.

4. Go to **Section 10** for transmission learning procedures.

-END SECTION 6-

Section 7

Installation of EconoMind Tuner with DynaFact Gauges

DynaFact gauges are a useful tool to monitor vehicle performance. There is a turbo boost gauge and an EGT gauge that will measure exhaust temperatures.

1. Run the Diagnostic Port Harness to the Tuner Harness. Plug the Diagnostic Port Harness into the Y-splitter. Use the Jumper Harness to connect the EconoMind and the Y-splitter together. You should feel the connectors lock together. Secure the Harnesses away from hot and/or moving engine.

CAUTION: When securing the wires, do not bend them any tighter than a 2.5" diameter bend as this can cause undue stress on the wires and may cause failure.

Pullers- skip to **Step 4.**

2. Pushers- Locate the Extension Harness in your kit. Connect the Harness to the Y-splitter and guide the Harness through the engine compartment to the bottom of the coach. Make sure the connectors lock together. Route the Harness to the front and attach to the coach's undercarriage and existing wiring harness using the supplied zip ties. Keep the Harness away from hot and/or moving parts.

3. Pushers- Connect the Extension Harness to the Cab Harness. The Cab Harness will go into your cab.

4. Pullers- Connect the Cab Harness to the Y-splitter. The Cab Harness will go into your cab.

5. Pass the Cab Harness into the cab through an existing body grommet or carefully drill a hole to access the cab compartment (Optional).

6. Optional: Know what is on the other side of the drilling area before drilling. Do not drill through any wires or electrical equipment. Drill a $\frac{3}{8}$ " hole and pass the Cab Harness through the cab. You may use a rubber grommet, thick putty, or expandable spray foam to help seal the hole against the elements. You may find them at a

local automotive or hardware store.

7. Choose a suitable location under the lower edge of the dash or on top for mounting the provided gauge panel where the driver can conveniently view it.

8. Using the panel as a template, drill two $\frac{3}{16}$ " diameter holes in the dash and mount the panel with the supplied machine screws, nuts and star washers provided.

9. Locate the supplied Cab Harness with the 4-pin connector. See **Figure**

6. Plug the 4-pin connector into the corresponding 4-pin receptacle from the EconoMind's Wire Harness.

10. Install the DynaFact boost and pyrometer gauges in the mounting panel using the clamps and thumbnuts provided. Plug the BLACK wire lead to the male spade terminal on the BLACK wire of each gauge wire harness. Plug the YELLOW wire into the Yellow wire of the boost gauge wire harness and the RED wire into the RED wire of the pyrometer gauge wire harness. The ORANGE wire remains unused.

11. Connect the 4-pin connector of each gauge into the back of its corresponding gauge.

- a. Crimp the remaining Black and RED wires from each 4-pin connector gauge harness to the butt connectors as shown in Figure 10.
- b. Strip one end of the RED wire and crimp to one of the butt connectors attached to the gauge harnesses in step 'a'.
- c. Strip one end of the BLACK wire and crimp to the other butt connector attached to the gauge harnesses in step 'a'.
- d. Route the RED wire to the fuse box. Locate the appropriate fuse for instrument lighting in the owner's manual. Cut the RED wire as required and strip the end. Crimp the push on connector

to the RED wire and connect to the fuse as shown in Figure 10. Alternatively, locate power wire to dimmer switch and install T-tap. Cut the RED wire as required and strip the end. Crimp the push on T-tap connector to the RED wire and connect to T-tap on dimmer power wire.

- e. Locate a metal surface that will serve as an acceptable chassis ground. Cut the BLACK wire to a sufficient length that will allow it to

reach the chassis ground and strip the end. Crimp the ring terminal to the BLACK wire as shown in Figure 10.

- f. Drill a 1/8" hole, if required, to attach the ring terminal to the chassis ground. Caution: If drilling, check the backside to make sure there are no components that may be damaged by drilling.
- g. Use the supplied self-tapping screw to secure the ring terminal to the chassis ground

Figure 19 4-PIN CONNECTORS TO GAUGE LED

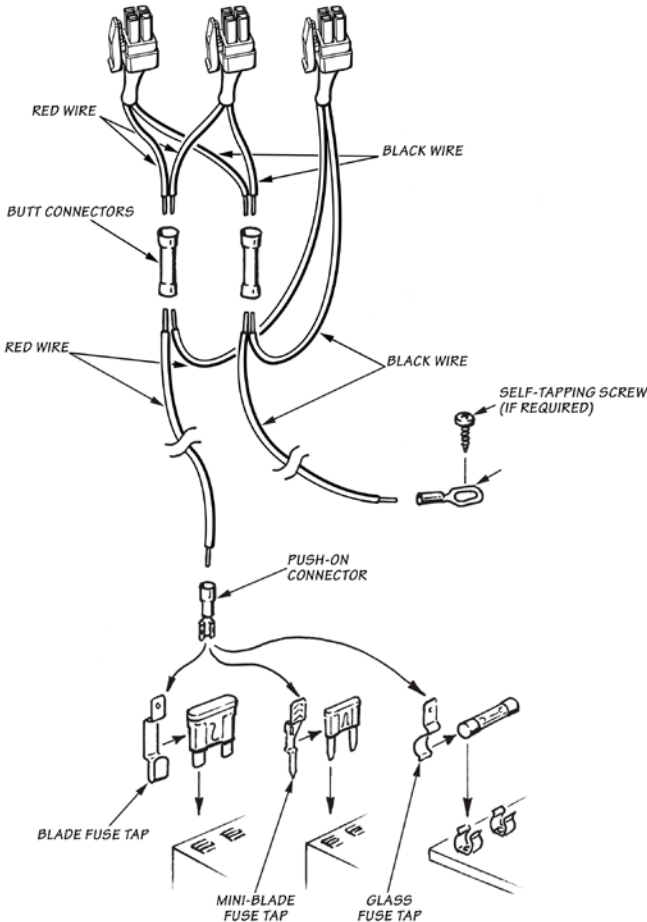

Section 8

Installation of EconoMind Tuner With PowerPDA

1. Run the Diagnostic Port Harness to the Tuner Harness. Connect the EconoMind Tuner and the Diagnostic Port Harnesses to the Y-splitter. You should feel the connectors lock together. Secure the harnesses away from hot and/or moving engine components with zip ties.

CAUTION: When securing the wires, do not bend them any tighter than a 2.5" diameter bend as this can cause undue stress on the wires and can cause failure.

Pullers- skip to **Step 4.**

2. Pushers- Locate the Extension Harness in your kit. Connect the harness to the Y-splitter making sure the connectors lock together. Guide the harness through the engine compartment to the bottom of the coach. Route the harness to the front and attach to the coach's undercarriage and existing wiring harness using the supplied zip ties. Keep the harness away from hot and/or moving parts.

3. Pushers- Connect the Extension Harness to the Cab Harness. The Cab Harness will go into your cab.

4. Pullers- Connect the Cab Harness to the Y-splitter. The Cab Harness will go into your cab.

5. Pass the Cab Harness into the cab through an existing body grommet or carefully drill a hole to access the cab compartment (Optional).

6. Optional: Know what is on the other side of the drilling area before drilling. Do not drill through any wires or electrical equipment. Drill a $\frac{3}{8}$ " hole and pass the Cab Harness through the cab. You may use a rubber grommet, thick putty, or expandable spray foam to help seal the hole against the elements. You may find them at a local hardware store.

7. Reconnect the battery ground cable(s).

8. Double check everything to make sure it is securely fastened and it is not near any hot or moving parts before starting engine.

-END SECTION 8-

Section 9

Mounting the Docking Station and Connecting the Banks PowerPDA

1. Locate the universal mount and docking station in your kit. Interlock the docking station to the universal mount by inserting and sliding the universal mount tabs into the docking station grooves. See **Figure 20**.

2. Find a smooth, flat surface suitable for ease of access and viewing of the PowerPDA. Loosen both knobs and move the swivel suction plate and docking station to achieve desired viewing angle of the PowerPDA screen. Do a test fit and note the angle necessary to achieve the correct viewing angle.

Note: There may be a snug fit when installing the PowerPDA into the docking station. Take care not to force this process.

3. Tighten both knobs to lock in the position (**Figure 20**).

*Note: If the universal mount swivel does not move or is tight after loosening the hold down knob, then remove the previously inserted docking station and slightly loosen the tension screw. See **Figure 21**.*

4. Locate the alcohol swab in the kit. Clean the suction cup and the mounting area and let dry. With the suction lever in the up position ensure the suction cup is flat against the windshield or smooth, flat surface. Then, push the suction lever down to secure in place.

5. Connect the Cab Harness connector to the PDA Cable. Plug the RJ12 connector (phone like connector at one end of the PDA Cable) into one of the receptacles in the base of the PDA docking station.

6. Install the Banks PowerPDA into the docking station. Be sure the PowerPDA is completely seated in the docking station against the lower support bracket.

Note: There may be a snug fit when installing the PowerPDA into the docking station. Take care not to force this process.

7. Plug the docking station's charging cable (seen in **Figure 20**) into the charging receptacle on the lower edge of the PowerPDA. Attach the PDA hub to a smooth, flat surface suitable for ease of access and viewing.

WARNING: The charging cable on the docking station is designed to supply a constant low-voltage power source (+5vdc) to the Banks PowerPDA and is "live" as long as the system's Diagnostic Port Cable is completely installed and the RJ12 connector is plugged into the docking station. Although this charging cable is short and its circuitry is fuse protected, the user is expected to take appropriate measures to prevent small children and/or pets from contact with any part of this system.

8. Route all wiring away from any pedals or other moving components. Using the cable ties supplied, secure the wiring under the dash.

9. Double check everything to make sure it is securely fastened and it is not near any hot or moving parts before starting engine.

10. Set up the Banks PowerPDA according to it's instructions.

11. Proceed to **Section 10**.

WARNING: The PDA may be susceptible to damage as a result of extended exposure to sunlight, heat or extreme cold. It is highly recommended that the PDA be removed from its mounting location if the vehicle will be subjected to high concentrations of sunlight, heat or cold for an extended period of time. Gale Banks Engineering is not responsible for damage to PDA's resulting from exposure conditions.

-END SECTION 9-

Figure 20

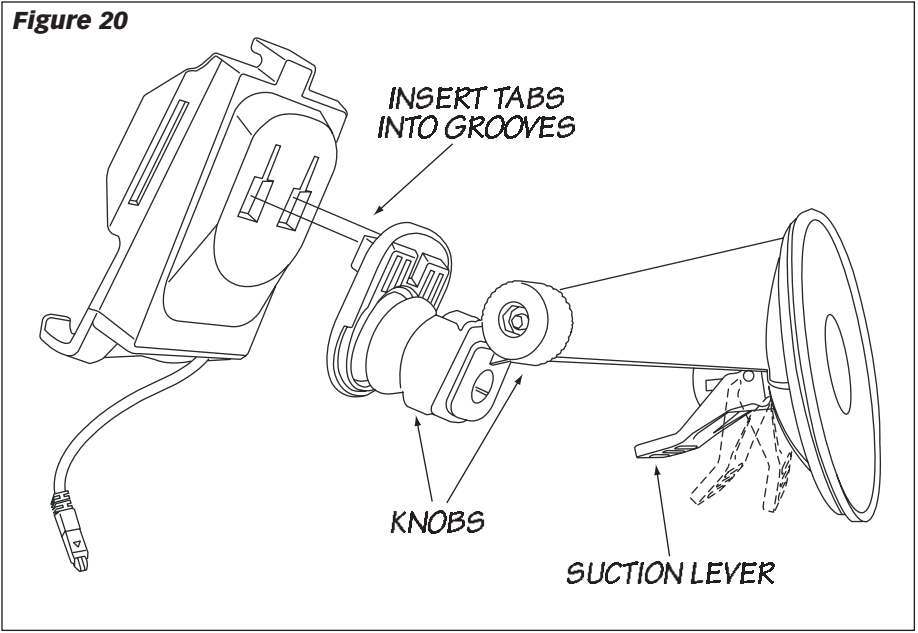
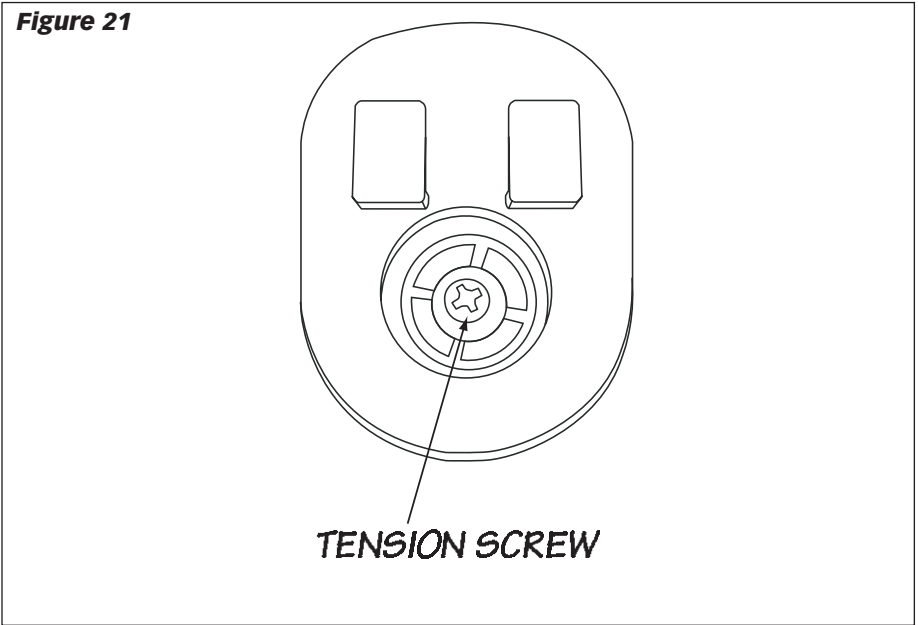

Figure 21



Section 10

Transmission Learning Procedures

The Banks EconoMind Tuner is equipped with advanced safety features to preserve your automatic transmission. One of them is the capability to detect the occurrence of transmission slip, and it will automatically de-rate the engine output power accordingly.

Before this safety feature can take effect, the EconoMind Tuner needs to learn that your coach is equipped with an automatic transmission.

- 1.** Go over the entire installation as a precautionary check to ensure that all clamps are tight, wiring and hoses are properly routed, and connections are tight.
- 2.** Turn the ignition key to the ON position. Check the EconoMind Tuner to make sure it's LED lights are on. The Tuner and/or PDA will give a warning initially. Usually, this is an unlearned transmission warning.

There are troubleshooting procedures in **Section 12**.

- 3.** Start the engine and wait 60 seconds. Listen for any exhaust leaks or rattles, or intake boost leaks. After the engine cools, re-tighten clamps and hoses if leaks are detected.
- 4.** Put foot on brake and put transmission into drive. Wait 30 seconds. The error code should clear after a few minutes.
- 5.** After completing **Step 4**, the transmission should have been detected by the EconoMind Tuner.

If so, continue to **Section 11**.

- 6.** If the error code has not cleared, then turn off the engine. Recheck all the connections to make sure they are fully locked and secure. Repeat **Steps 1** through **4**.

- 7.** If the error code still has not cleared, continue to **Step 8**.

- 8.** The following driving test shall be performed in an area where speeds over 55mph are safe and traffic is light.

While driving, listen for any exhaust leaks or rattles, or intake boost leaks. After the engine cools, re-tighten clamps and hoses if leaks are detected.

- 9.** Carefully bring the coach up to a speed of 60 MPH without cruise control and a heavy load. With the turbo boost below 10psig (i.e., light load), maintain the attained speed steadily for at least 30 seconds. Once the transmission is learned, the "4,3" diagnostic code will be eliminated on the Tuner and if installed, on the optional PowerPDA. Repeat if necessary to eliminate code. It may take a few minutes for the code to clear.

There are troubleshooting procedures in **Section 12**.

-END SECTION 10-

Section 11

Checking Engine Performance

1. Go over the entire installation as a precautionary check to ensure that all clamps are tight, wiring and hoses are properly routed, and connections are tight.

2. Start the engine and gently drive the vehicle to allow it to warm up. Drive the vehicle under light load (normal around town driving) for 20 to 30 minutes, and listen for any exhaust leaks or rattles, or intake boost leaks. Shut off the engine and allow it to cool. Re-tighten all intercooler and turbocharger boost clamps. These connections may have loosened with time, and if leaking, will cause a drop in boost pressure with a loss in performance. Check that clamps are properly positioned on hoses, and periodically check tightness of hose clamps at regular maintenance intervals, such as when the oil is changed.

3. The EconoMind Diesel Tuner requires the engine coolant temperature (ECT) to be above 110° before it will add fuel. If the DynaFact gauges or the optional Banks PowerPDA are installed, observe the operation of the boost and pyrometer (EGT) gauge values while driving under varying conditions. Turbocharger boost pressure will increase as a function of load and engine RPM, thus the engine will produce little boost while cruising at light throttle, with maximum boost occurring while climbing hills, heavily loaded, and/or during acceleration. Note the boost level seen during hard acceleration with a given load. If performance seems to have deteriorated sometime in the future, the maximum boost figures may be compared to see if boost has dropped off. Lower boost may be caused by turbo ducting leaks, a malfunctioning wastegate, fuel injection pump, and/or dirty air filter.

Typical maximum boost pressure settings for the Cummins diesel will vary considerably with year model of vehicle, options, and altitude.

Note: Before key-off, check Tuner for error codes.

4. Use your Banks PowerPDA or EGT gauge to monitor exhaust gas temperature (EGT) in the engine. At idle, exhaust gas temperature will be very low, perhaps only 300°F. As the engine is accelerated for higher speeds with greater loads, the EGT will rise. The highest EGT will be seen under maximum load at full throttle, such as climbing a steep grade with a heavily laden vehicle. Your EconoMind is calibrated to maintain a maximum EGT of 1300°F. The EGT may exceed 1300° for short periods of time during high-load conditions. This is normal and EGT should return to at or below 1300° within a few seconds. If you find that EGT remains high for any length of time, check for boost leaks, a malfunctioning wastegate, fuel injection pump, and/or dirty air filter.

CAUTION: To avoid heat damage to various engine components it is recommended that the exhaust gases cool below 400° before the engine is shut down.

-END SECTION 11-

Section 12

Troubleshooting with EconoMind Tuner's LEDs

Your Banks EconoMind Diesel Tuner is equipped with diagnostic features that will detect and display certain errors. Turn the vehicle key to the ON position. Observe the two LEDs mounted on the end of the EconoMind Diesel Tuner, next to the harnesses.

If a connection is incorrect or if there is a problem with the system, when the ignition is ON the RED LED will flash in sequence to identify a diagnostic code. An EconoMind Diesel Tuner's diagnostic code is comprised of 2 digits. Each code is expressed in a sequence of 2 sets of the flashing RED LED separated by a brief flashing of the GREEN LED in between. Each set of a number of RED LED flashes represents a digit. A longer flashing of the GREEN LED separates the sequences. The LEDs will continue to flash to display all the errors, and then repeat. **Table 1** lists the available diagnostic codes and their recommended course of action for each.

- A steady GREEN LED will illuminate if all wire connections are correct, the engine is running, and the engine coolant temperature is within its normal operating range.

- The GREEN LED will flash if all wire connections are correct, the engine is running, but the engine coolant temperature is not within its normal operating range. The GREEN LED will stop flashing and stay lit once the engine coolant temperature is within its normal operating range.

- No LEDs will illuminate if the fuse on the EconoMind wiring harness is blown or the wiring harness is not properly connected. If the fuse and all connections are okay, contact Banks Technical Service.

- The RED LED will flash in a certain sequence if a connection is incorrect or if there is a problem with the system – this sequence will identify one or more diagnostic codes. A Banks EconoMind Diesel Tuner's diagnostic code is comprised of 2 digits. Each code is expressed in a sequence of 2 sets of the flashing red LED separated by a brief flashing of the green LED in between. Each set of a number of red LED flashes represents a digit. A longer flashing of the green LED separates the sequences. The LEDs will continue to flash to display all the errors, and then repeat. **Table 1** lists the common diagnostic codes. For example, if a faulty thermocouple is detected (code "2,3") by the Banks EconoMind Diesel Tuner, the following red and green LED flashing sequence is observed when the key is on:

(1) Two times flashing RED LED

(2) One time quick flashing GREEN LED

(3) Three times flashing RED LED

(4) One time longer flashing GREEN LED

The above flashing sequence will repeat continuously. When the problem is corrected, the diagnostic code will be eliminated and replaced by a steady green light.

Note: If multiple codes are set, they will be displayed in a series separated by the longer flashing green LED. When reading codes, make sure to watch the entire series until you see the first code repeat.

-END SECTION 12-

Table 1 Banks EconoMind Fault Codes

Code	Event	Course of Action
1,1	Fuel Rail Pressure (FRP) Input Voltage Out of Range.	Turn ignition OFF and check 3-pin FRP sensor connections. Turn ignition back ON and re-check for presence of code.
1,2	Manifold Absolute Pressure (MAP) Input Voltage Out of Range.	Turn ignition OFF and check 3-pin MAP sensor connections. Turn ignition back ON and re-check for presence of code.
1,4	J1587 Communications Error With Vehicle.	Turn ignition OFF and check Diagnostic Port Harness connections. Turn ignition back ON and re-check for presence of code.
2,1	Fuel Rail Pressure (FRP) Output Voltage Out of Range.	Turn ignition OFF and check 3-pin FRP sensor connections. Turn ignition back ON and re-check for presence of code.
2,2	Manifold Absolute Pressure (MAP) Output Voltage Out of Range.	Turn ignition OFF and check 3-pin MAP sensor connections. Turn ignition back ON and re-check for presence of code.
2,3	Exhaust Gas Temperature (EGT) Sensor Open Circuit	Turn ignition OFF and check thermocouple ring-terminal connections (2). Turn ignition back ON and re-check for presence of code.
2,4	J1939 Communications Error With Vehicle.	Turn ignition OFF and check Diagnostic Port Harness connections. Turn ignition back ON and re-check for presence of code.
3,1	Engine Crankshaft Position (CKP) Sensor Fault or Intermittent Power.	Turn ignition OFF and check 3-pin CKP sensor connections and fuse-tap power connection to EconoMind Tuner (in fuse box). Start engine and re-check for presence of code.
3,2	Internal Module Malfunction.	Turn ignition OFF and check all EconoMind Tuner connections. Turn ignition back ON and re-check for presence of code.
3,3	Low Battery Voltage or Internal Module Malfunction.	Turn ignition OFF and check fuse-tap power connection to EconoMind Tuner (in fuse box). Make sure the vehicle's battery is at least 12v. Turn ignition back ON and re-check for presence of code.
4,2	Transmission Slippage Detected.	Transmission is slipping excessively. Code will automatically clear once transmission stops slipping (repaired).
4,3	Unlearned Transmission Type and Gear Ratios.	Perform Transmission Learning procedure in Section 9. Code will automatically clear once transmission type and gear ratios (auto trans. only) have been learned successfully.

If problem persists, call Gale Banks Engineering Tech Support.

Section 13

Troubleshooting EconoMind Tuner with PowerPDA

The standard Banks EconoMind Diesel Tuner requires the engine coolant temperature (ECT) to be above 110° before it will add fuel. If you feel that your EconoMind Diesel Tuner is not functioning properly, some diagnostics can be performed. Check the Banks PowerPDA's Status Indicator for the "OK" icon. Any EconoMind Tuner fault will be indicated by the "Banks Engine" icon (see **Figure 22**) and its cause can be investigated by going to the 'Self Diagnostics' screen and scrolling through the list of logged Tuner events.

Figure 22



ECONOMIND TUNER ICON

1. Press the center button on the 5-way navigator to take you to the System Menu screen (**Figure 23**).
2. Touch the button labeled 'More>' to move to the second screen of the System Menus.
3. Next, touch the 'Self Diagnostics' button. (See **Figure 24**)
4. The 'Self Diagnostics' screen displays a log of diagnostic events related to the EconoMind Tuner (See **Figure 25**). The 'Logged Events' list takes a moment to update each time this screen is opened (as indicated by a slight flickering of the list). Once the list is updated, the most current event will appear at the top of the list. Each event has an associated time stamp and description, which will be displayed below the list when that

Figure 23

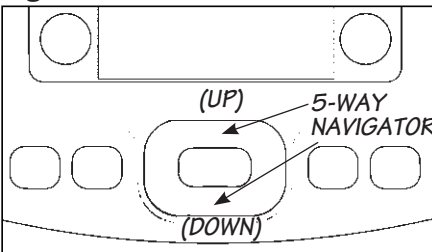

event is highlighted. Each key cycle of the vehicle produces a minimum of two logged events. (See **Figure 25**)

5. Touch the 'Down' or 'Up' buttons to scroll through the list of recorded events. **Table 1** lists the available diagnostic codes and the recommended course of action for each.
6. Touch the center button on the 5-way navigator (or the 'Back' button) to return to the System-Monitor screen.

-END SECTION 13-

Figure 24



Figure 25

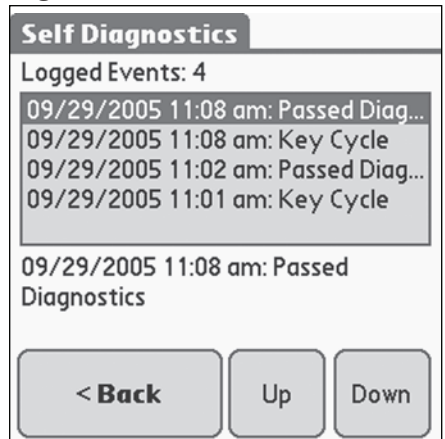

Section 14

Removal of the EconoMind Tuner

If the EconoMind Tuner should ever need to be removed from the vehicle, perform the following:

CAUTION: The ignition must remain in the OFF position and the engine must be cool throughout the removal process.

1. Disconnect the ground cable from the battery before beginning work. If there are two batteries, disconnect both.
2. Clip the necessary cable ties to free the EconoMind Tuner's wires for removal.
3. Disconnect the EconoMind CKP sensor connectors from the CKP sensor and factory connector. Re-attach the factory connector to the CKP sensor.

Note: The connectors will need to be unlocked before removal and locked after re-connection.

4. Disconnect the EconoMind MAP connectors from the MAP sensor and factory connector. Re-attach the factory connector to the MAP sensor. Lock the connector.
5. Disconnect the EconoMind FRP connectors from the FRP sensor and factory connector. Re-attach the factory connector to the FRP sensor.

Note: Press and hold the locking clip to unlock the connectors from each other. Make sure each connector is secured and locked properly to their sensors.

6. Cut the EGT sensor's heat shrink tubing open using a razor blade or sharp knife. Take care not to cut through the outer insulation of the wires. Remove the EGT sensor wires from the EconoMind's EGT ring terminals. The EGT sensor may be left in place or removed if a suitable plug is installed in place of the EGT sensor in the exhaust manifold.

7. Unbolt the EconoMind's ground wire Re-install bolt and tighten.

8. Disconnect EconoMind's Diagnostic Port Harness from the Tuner Harness by pressing and holding the locking clip while separating the connectors. All the wires should be free from the Tuner.

9. Unbolt Tuner from it's mounting location to remove it from the coach.

10. From the diagnostic port, unlock the Banks' Protective Cover from the stock protective cap. Unlock the EconoMind's Diagnostic Port Harness by turning the locking ring counter-clockwise (to the left). Remove the connector from the diagnostic port. Cover the port with the stock protective cap (if available). Remove Diagnostic Port Harness.

11. From inside the coach, press and hold the locking clip on the EconoMind's Cab Harness while disengaging the connectors from each other.

12. Push and hold the locking clip while removing the Cab Harness from the PDA or DynaFact gauge cable.

13. Remove PowerPDA or DynaFact gauges from their location, if so desired.

14. Pushers- Remove the EconoMind Tuner's extension harness.

15. Reconnect the battery ground cable(s).

CAUTION: Failure to follow the above instructions when removing the EconoMind Tuner will result in a "Check Engine" light on the dash and a Diagnostic Trouble Code being stored in the factory computer, in addition to the engine not running.

-END SECTION 14-

Gale Banks Engineering
546 Duggan Avenue • Azusa, CA 91702
(626) 969-9600 • Fax (626) 334-1743

Product Information & Sales: (888) 635-4565

bankpower.com

Palm® is a registered trademark, and Tungsten™ is a trademark of Palm Inc.