

banks

with Installation Instructions
Owner's Manual

Banks Monster[®] Exhaust System

2003-2005 Dodge Ram 1500 HEMI
2003-2005 Dodge Ram 2500 HEMI
2002-2003 Dodge Ram 1500 4.7L MAGNUM

THIS MANUAL IS FOR USE WITH MONSTER EXHAUST SYSTEMS 48565-48575

Gale Banks Engineering
546 Duggan Avenue • Azusa, ca 91702
(626) 969-9600 • Fax (626) 334-1743

Product Information & Sales: (888) 635-4565

bankspower.com

General Installation Practices

Dear Customer,

If you have any questions concerning the installation of your Banks Monster Exhaust System, please call our Technical Service Hotline at (888) 839-2700 between 7:00 am and 5:00 pm (PT). If you have any questions relating to shipping or billing, please contact our Customer Service Department at (888) 839-5600.

Thank you.

1. Before starting work, familiarize yourself with the installation procedure by reading all of the instructions.
2. The exploded view (**Figure 1**) provides only general guidance. Refer to each step and section diagram in this manual for proper instruction.
3. Throughout this manual, the left side of the vehicle refers to the driver's side, and the right side to the passenger's side.
4. Disconnect the negative (ground) cable from the battery (or batteries, if there are two) before beginning work.
5. Route and tie wires and hoses a minimum of 6" away from exhaust heat, moving parts and sharp edges. Clearance of 8" or more is recommended where possible.
6. When raising the vehicle, support it on properly weight-rated safety stands, ramps or a commercial hoist. Follow the manufacturer's safety

precautions. Take care to balance the vehicle to prevent it from slipping or falling. When using ramps, be sure the front wheels are centered squarely on the topsides; put the transmission in park; set the hand brake; and place blocks behind the rear wheels.

Caution! Do not use floor jacks to support the vehicle while working under it. Do not raise the vehicle onto concrete blocks, masonry or any other item not intended specifically for this use.

7. During installation, keep the work area clean. Do not allow anything to be dropped into intake, exhaust, or lubrication system components while performing the installation, as foreign objects will cause immediate engine damage upon start-up.

Tools Required:

- 1/2" and 3/8" drive ratchets with standard and metric sockets and 1/2" and 3/8" drive extension
- Standard and metric combination or open-end wrenches
- Standard screwdriver
- Clean shop towels or rags
- Pry-bar

Highly recommended tools and supplies:

- Foot-pound torque wrench
- Penetrating oil or light lubricant spray

Monster Exhaust System Installation

1. Disconnect the negative (ground) cable from the battery (if there is more than one battery, disconnect both negative cables). Secure the cable so it cannot accidentally come in contact with the post.

2. Raise the vehicle and support it securely with properly weight-rated safety stands, ramps or a commercial hoist. Take care to balance the vehicle to prevent it from slipping or falling. When using ramps, be sure the wheels are centered squarely on the topsides. Place the transmission in park (automatic), set the parking brake and securely block the wheels that are on the ground.

CAUTION: DO NOT WORK UNDER ANY VEHICLE SUPPORTED ONLY BY A JACK. SEVERE INJURY MAY RESULT.

3. From under the vehicle remove the factory exhaust starting at the rear of the muffler. Remove the tailpipe by removing the factory band clamp on the muffler to tailpipe connection. Remove the factory tailpipe hanger pin (attached to resonator) from the rubber grommet and remove the tailpipe from the vehicle.

NOTE: Spray lubricant may assist in hanger pin removal.

4. Loosen the factory band clamp at the front of the muffler. Remove the front and dual rear muffler hanger pins from the rubber grommets. Remove the muffler from the vehicle.

5. If applicable, loosen the factory band clamp on the front of the intermediate pipe just behind the factory Y-pipe. Remove the intermediate pipe hanger pin from the rubber grommet and remove the intermediate pipe from the vehicle.

6. FOR STAND, CAB LONG BED AND CREW CAB MODELS ONLY: Due to the enormous weight reduction of the Banks Exhaust system, the factory intermediate pipe rubber hanger will not be used on Std. Cab Long Bed and Crew Cab models. You may remove the factory intermediate pipe rubber grommet if desired (see **Figure 2**).

7. Install the intermediate pipe clamp onto the inlet of the Banks intermediate pipe (See the General Assembly Diagram to verify the intermediate pipe p/n). Install the Banks intermediate pipe to the factory Y-pipe outlet. Orient the intermediate pipe onto the locating pin on the top of the factory Y-pipe. Lightly tighten the intermediate pipe clamp (see **Figure 2**).

NOTE: All clamps should be positioned at the beginning of the slots, on the 1/2 circle.

8. Install the 3" single hanger clamp into the rubber grommet and onto the intermediate pipe with the hanger pin facing forward. Install the Banks Muffler inlet (*Note the inlet labeling of the muffler*) onto the intermediate pipe and lightly tighten the 3" hanger clamp (see **Figure 3**).

9. Install the 3" dual hanger clamp onto the Banks Muffler outlet such that the hanger pins are facing forward. Install the two (2) clamp hanger pins into the corresponding muffler rubber grommet (see **Figure 3**).

10. From the vehicle rear, route the tailpipe over the rear end. Start the tailpipe hanger pin into the corresponding vehicle rubber hanger. Install the tailpipe into the Banks Muffler outlet. Lightly tighten the rear muffler hanger clamp to secure the tailpipe (see **Figure 3**).

General Assembly Diagram

Figure 1

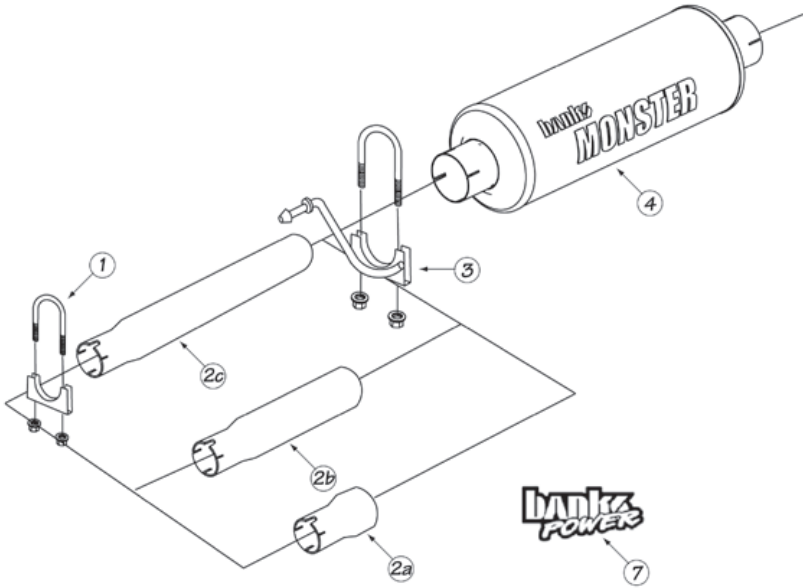

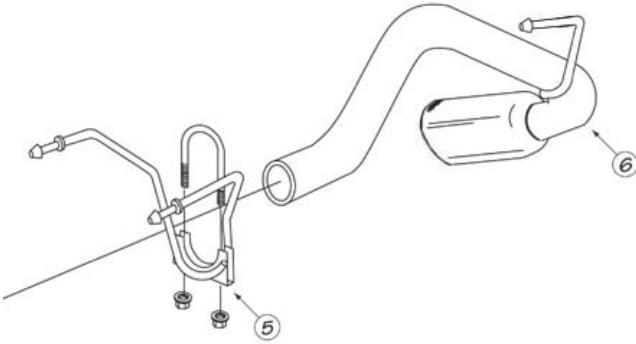

Item #	Description	Banks P/N				QTY
		04-05 Hemi Ram 1500	03 Hemi Ram 1500	03-05 Hemi Ram 2500	02-03 Ram 1500	
1	Clamp, Intern Pipe	52463	52465	52465	52461	1
2a	Std. Cab SB Intern. Pipe (120" WB)	53205	-	-	-	1
2b	CCSB/SCLB Intern. Pipe (140" WB)	53206	53212	53215	53220	1
2c	Crew Cab LB Intern. Pipe (160" WB)	53207	-	-	-	1
3	3" Hanger Clamp, Front, Muffler	53208	53208	53217	53208	1
4	Monster Muffler	54005	54005	54005	54005	1
5	3" Hanger Clamp, Rear, Muffler	53209	53209	53218	53209	1
6	Tailpipe	53210				1
7	Banks Urocal	96009				2

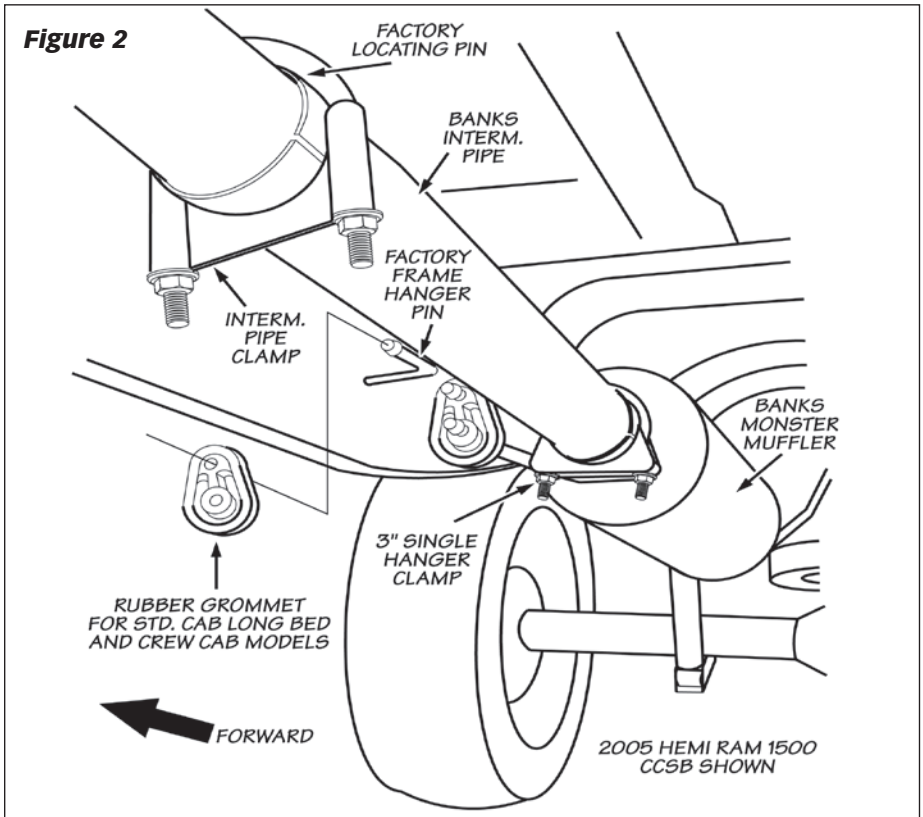

11. Adjust the tip about 1/2" to 1" under the body panel, inline with the vehicle body, such that the tip position is aesthetically pleasing. (See **Figure 4**).

12. With the exhaust positioned properly, begin to evenly tighten clamps starting with the ones closest to the front of the vehicle and working your way back. Torque the exhaust clamps evenly to 35 ft-lbs. Make sure that each slip is fully inserted (+/- 1/4").

13. Remove the protective covering from the tailpipe tip.

Caution: the protective covering may ignite and burn if not removed prior to running the engine.

14. Your system includes two (2) Banks Power logos designed to complement the Dodge HEMI emblems on the vehicles front fenders. Use the provided measurements for a clean factory look (see **Figure 5**). For non-Hemi models, place decal in place of the Hemi emblem.

15. Re-connect the negative battery cable. Start the engine and listen for exhaust leaks. Tighten the exhaust clamps as necessary. Whenever possible, tack weld slip connections to prevent disengagement is recommended. The Banks Monster Exhaust installation is now complete.

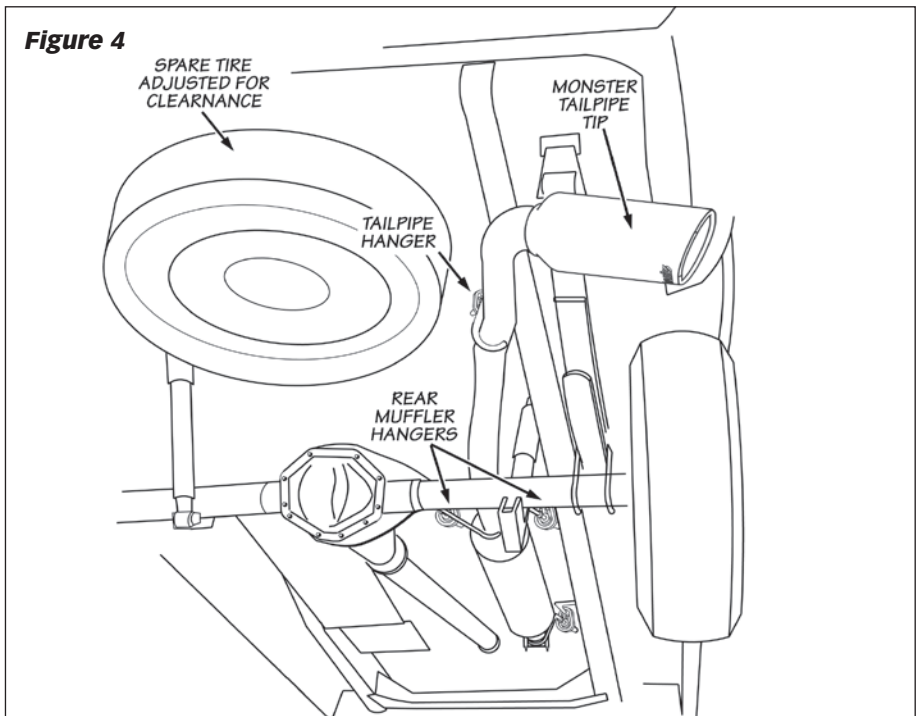
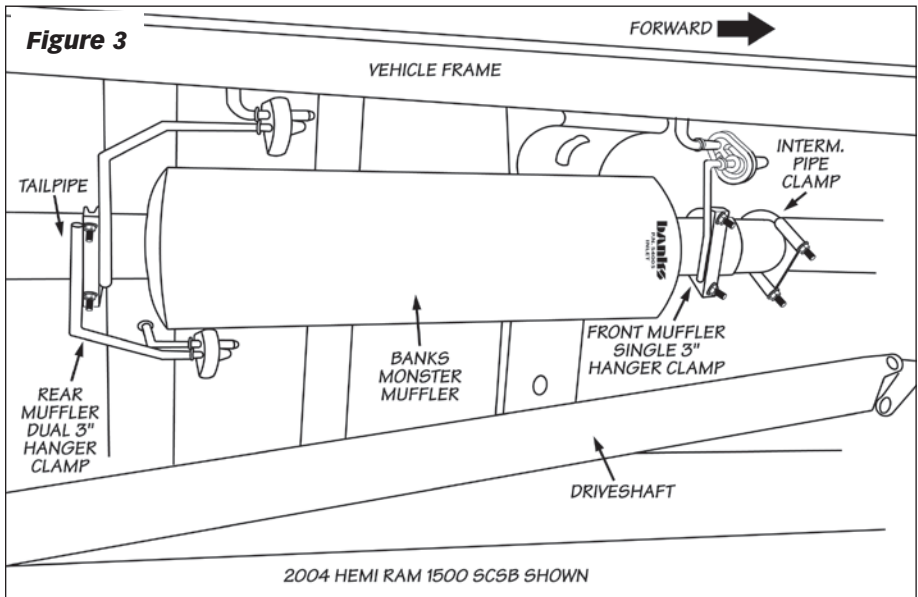
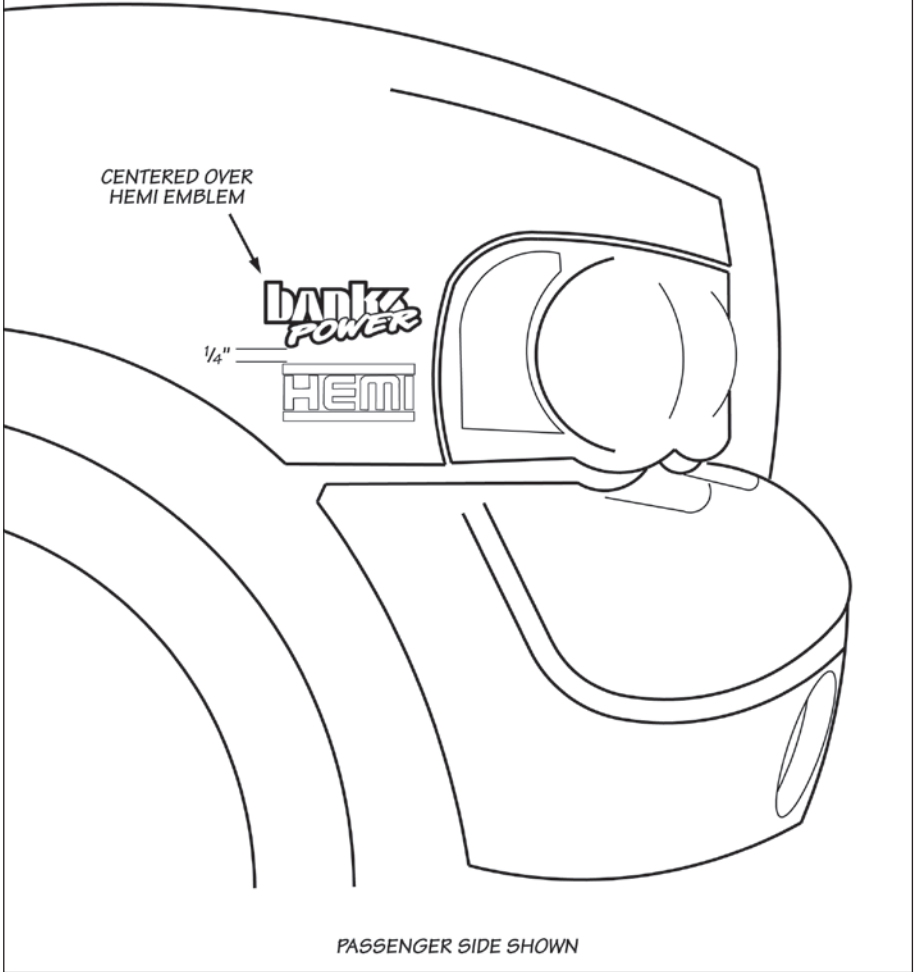

Figure 5



Gale Banks Engineering
546 Duggan Avenue • Azusa, ca 91702
(626) 969-9600 • Fax (626) 334-1743

Product Information & Sales: (888) 635-4565

bankspower.com