

Owner's Manual with Installation Instructions

Banks Monster[®] Exhaust System

**2009 Dodge Ram 1500 5.7L HEMI
Crew Cab Short Bed Only**

THIS MANUAL IS FOR USE WITH MONSTER EXHAUST SYSTEM 48580

Gale Banks Engineering
546 Duggan Avenue • Azusa, Ca 91702
(626) 969-9600 • Fax (626) 334-1743

Product Information & Sales: (888) 635-4565

bankspower.com



General Installation Practices

Dear Customer,

If you have any questions concerning the installation of your Banks Monster Exhaust System, please call our Technical Service Hotline at (888) 839-2700 between 7:00 am and 5:00 pm (PT). If you have any questions relating to shipping or billing, please contact our Customer Service Department at (888) 839-5600.

Thank you.

- 1.** Before starting work, familiarize yourself with the installation procedure by reading all of the instructions.
- 2.** The exploded view (**Figure 1**) provides only general guidance. Refer to each step and section diagram in this manual for proper instruction.
- 3.** Throughout this manual, the left side of the vehicle refers to the driver's side, and the right side to the passenger's side.
- 4.** Disconnect the negative (ground) cable from the battery (or batteries, if there are two) before beginning work.
- 5.** Route and tie wires and hoses a minimum of 6" away from exhaust heat, moving parts and sharp edges. Clearance of 8" or more is recommended where possible.
- 6.** When raising the vehicle, support it on properly weight-rated safety stands, ramps or a commercial hoist. Follow the manufacturer's safety precautions. Take care to balance the

vehicle to prevent it from slipping or falling. When using ramps, be sure the front wheels are centered squarely on the topsides. When raising the front of the vehicle, put the transmission in park, set the parking brake, and block the rear wheels. When raising the back of the vehicle, be sure the vehicle is on level ground and the front wheels are blocked securely.

CAUTION! Do not use floor jacks to support the vehicle while working under it. Do not raise the vehicle onto concrete blocks, masonry or any other item not intended specifically for this use.

7. During installation, keep the work area clean. Do not allow anything to be dropped into intake, exhaust, or lubrication system components while performing the installation, as foreign objects will cause immediate engine damage upon start-up.

Tools Required:

- 1/2" and 3/8" drive ratchets with standard and metric sockets and 1/2" and 3/8" drive extension
- Standard and metric combination or open-end wrenches
- Standard screwdriver
- Clean shop towels or rags
- Pry-bar

Highly recommended tools and supplies:

- Foot-pound torque wrench
- Penetrating oil or light lubricant spray

General Assembly Diagram

Figure 1

Item #	Description	P/N	Qty
1	Exhaust Clamp, 3" HD	53465	2
2	Intermediate Pipe	53237	1
3	Monster Muffler	54005	1
4	Rear Muffler Hanger Clamp	53238	1
5	Tailpipe, w/weld on Tip	53239	1
6	Banks Urocalcs	96009	2

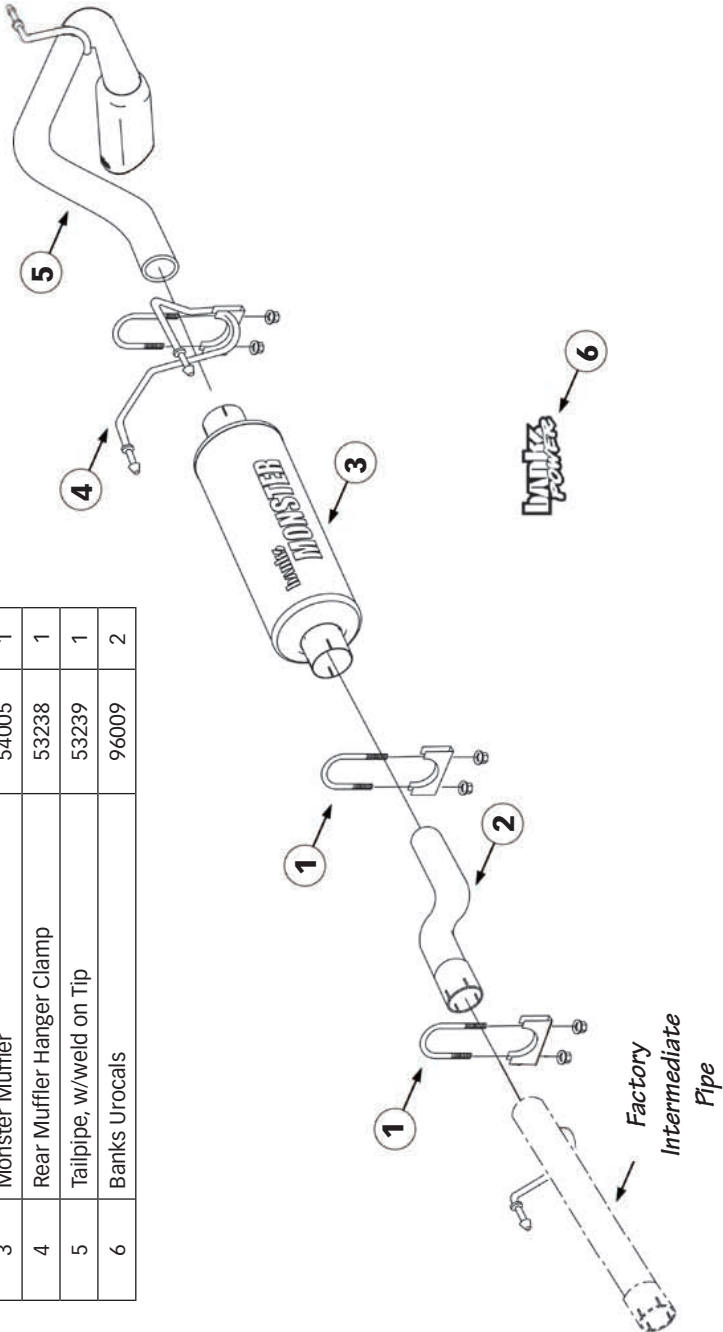

Monster Exhaust System Installation

1. Disconnect the negative (ground) cable from the battery (if there is more than one battery, disconnect both negative cables). Secure the cable so it cannot accidentally come in contact with the post.

2. Raise the vehicle and support it securely with properly weight-rated safety stands, ramps or a commercial hoist. Take care to balance the vehicle to prevent it from slipping or falling. When using ramps, be sure the wheels are centered squarely on the topsides. Place the transmission in park (automatic), set the parking brake and securely block the wheels that are on the ground.

CAUTION: DO NOT WORK UNDER ANY VEHICLE SUPPORTED ONLY BY A JACK. SEVERE INJURY MAY RESULT.

3. From under the vehicle remove the factory exhaust starting at the rear of the muffler. Remove the tailpipe by removing the factory band clamp on the muffler to tailpipe connection. Remove the factory tailpipe hanger pin (attached to resonator) from the rubber grommet and remove the tailpipe from the vehicle.

NOTE: Spray lubricant may assist in hanger pin removal. Rubber hangers can also be removed from the vehicle to assist in tailpipe / muffler removal.

4. Loosen the factory band clamp at the front of the muffler. Disconnect the ground cable from the muffler hanger pin. Remove the dual rear muffler hanger pins from the rubber hangers. Remove the muffler from the vehicle. The factory intermediate pipe will remain on the vehicle.

5. Install the 3" Exhaust clamp onto the inlet of the Banks intermediate pipe. Install the Banks intermediate pipe onto

the factory intermediate pipe. Orient the intermediate pipe as shown in **Figure 2**.

NOTE: Once the pipe / muffler has been completely engaged in the slip joint, mark the pipe with a scribe or tape for reference when tightening the clamps later in the installation. Mark each slip joint in this fashion.

6. Install a 3" Exhaust clamp onto the intermediate pipe outlet. Install the Monster Muffler inlet (Note the inlet labeling of the muffler). Orient the Monster logo such that it is visible from the passenger side and parallel with the frame rail. Align the clamp onto the muffler outlet (see **Figure 2**).

NOTE: All clamps should be positioned at the beginning of the slots (on the 1/2 circle punch) and evenly tightened.

7. Install the 3" dual hanger clamp onto the Banks Muffler outlet such that the hanger pins are facing forward. Install the two (2) clamp hanger pins into the corresponding muffler rubber grommet. Connect the ground cable from the vehicles hanger pin to the left hanger pin on the dual hanger clamp. See **Figure 3**.

8. From the vehicle rear, route the tailpipe over the rear track bar. Start the tailpipe hanger pin into the corresponding vehicle rubber hanger. Install the tailpipe into the Banks Muffler outlet. Lightly tighten the rear muffler hanger clamp to secure the tailpipe (see **Figure 4**).

9. Adjust the tip about 1/2" under the body panel, such that the tip position is aesthetically pleasing (See **Figure 4**).

10. With the exhaust positioned properly, begin to tighten the clamps starting with the ones closest to the front of the vehicle and working your way back. Torque the exhaust clamps evenly to 35 ft-lbs. Make sure that each slip is fully inserted (+/- 1/4").

Figure 2

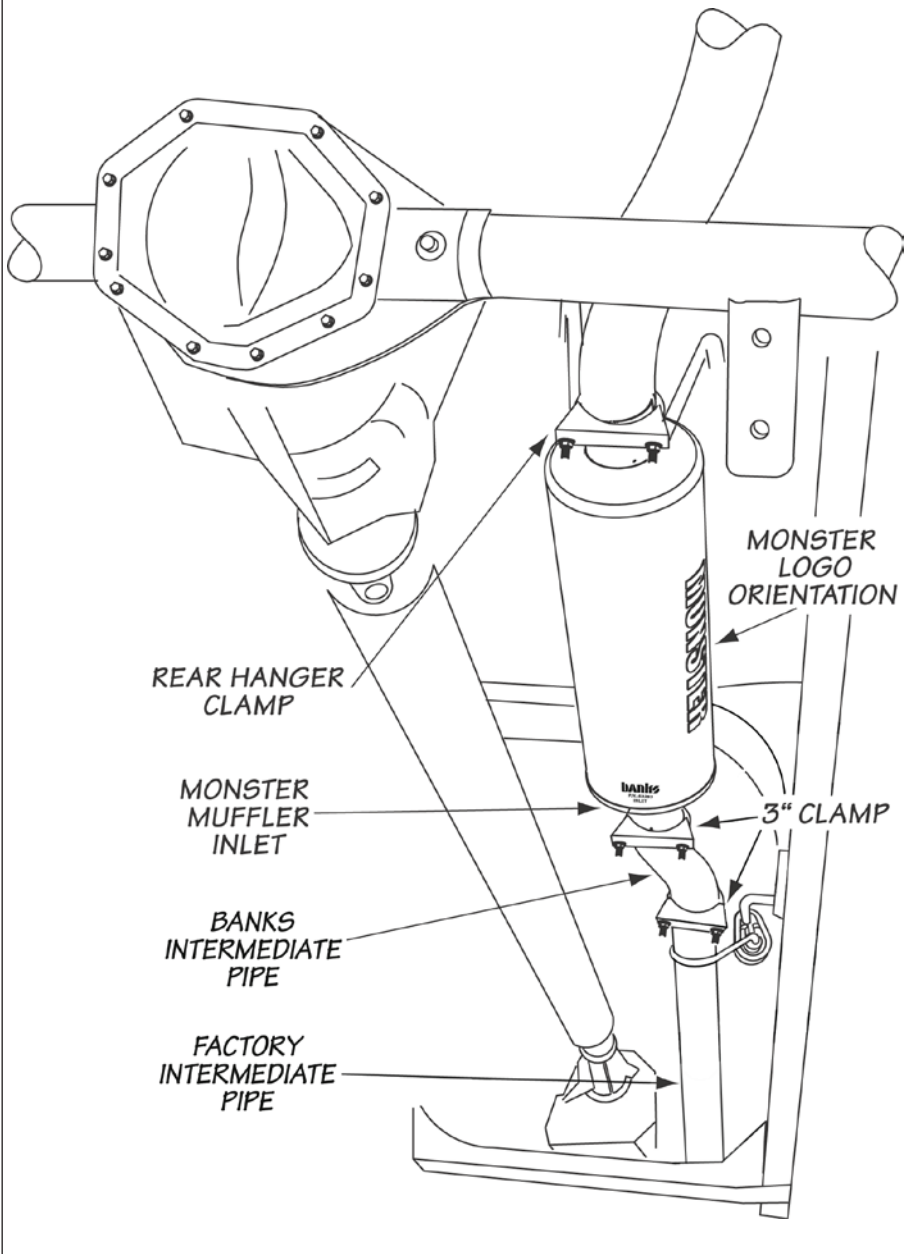
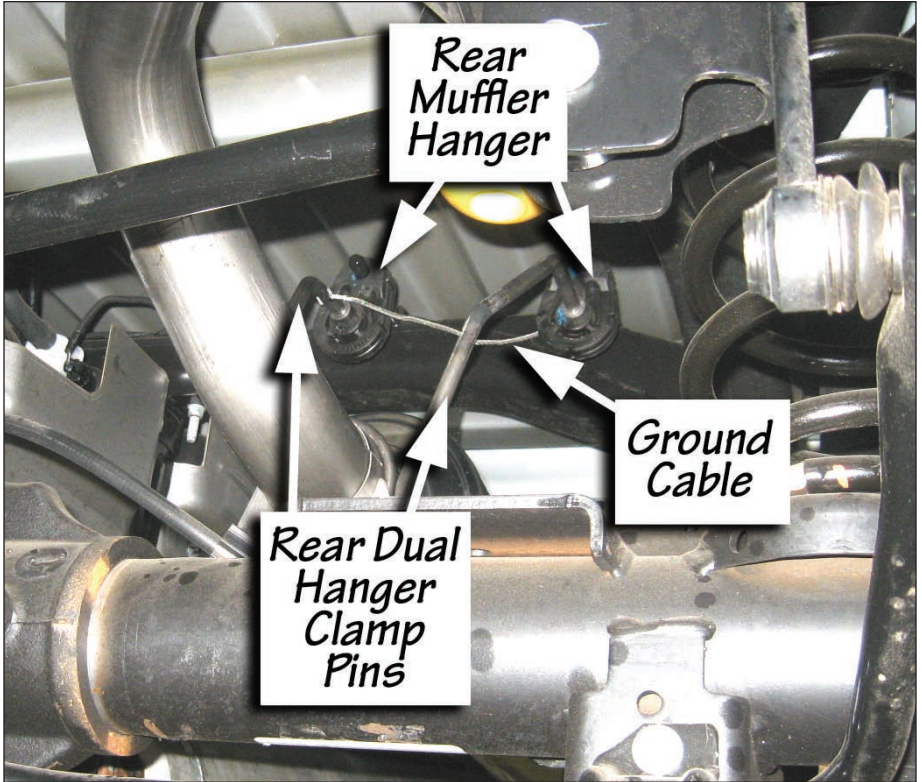

Figure 3



11. Remove the protective covering from the tailpipe tip.

Caution: the protective covering may ignite and burn if not removed prior to running the engine.

12. Your system includes two (2) Banks Power logos designed to complement the Dodge HEMI emblems on the vehicles front fenders.

13. Re-connect the negative battery cable. Start the engine and listen for exhaust leaks. Tighten the exhaust clamps as necessary. Whenever possible, tack weld slip connections to prevent disengagement is recommended.

The Banks Monster Exhaust installation is now complete.

Figure 4

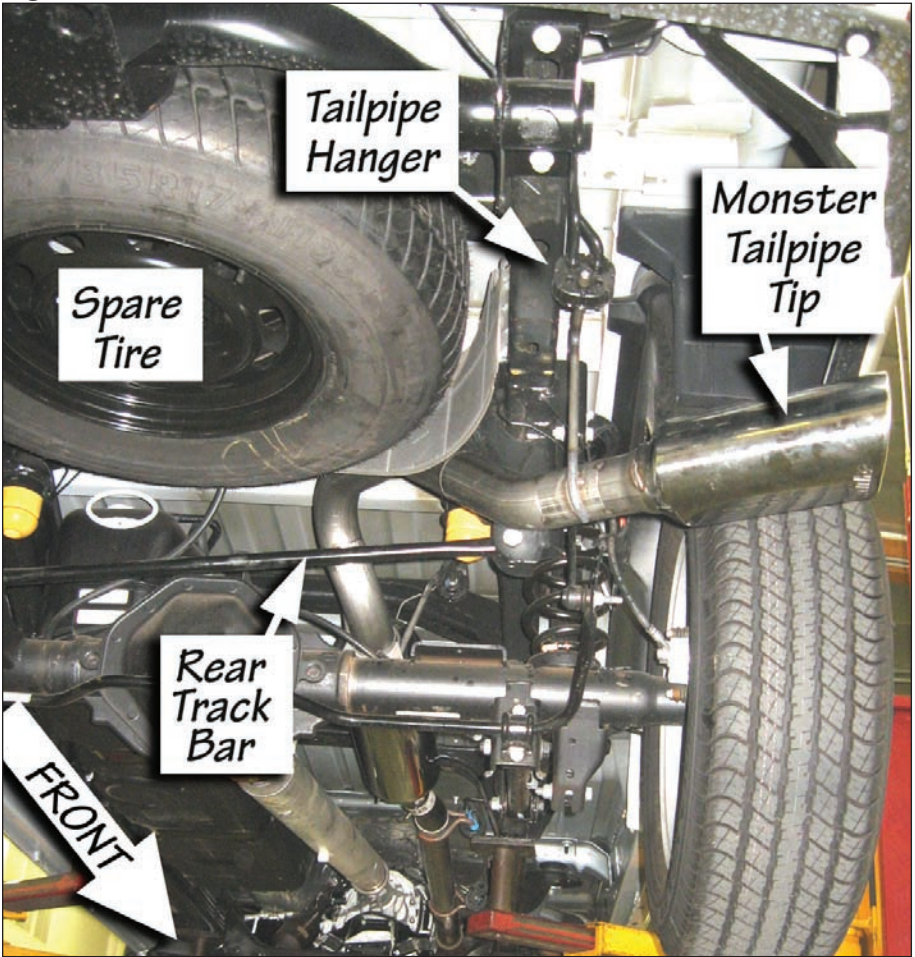

Gale Banks Engineering
546 Duggan Avenue • Azusa, CA 91702
(626) 969-9600 • Fax (626) 334-1743

Product Information & Sales: (888) 635-4565

bankspower.com