

OWNERS MANUAL

WITH INSTALLATION
INSTRUCTIONS

banks

POWERPACK

S Y S T E M [®]

FORD 460 EFI CLASS-A MOTORHOMES
FORD CHASSIS, NON-CATALYTIC CONVERTER

THIS MANUAL IS FOR USE WITH SYSTEM PART NUMBER 49090

banks

Gale Banks Engineering
546 duggan avenue • azusa, ca 91702
(626) 969-9600 • fax (626) 334-1743

Product Information & Sales: (800) 438-7693
www.bankspower.com

**POWERPACK® SYSTEM
FORD 460 EFI ENGINE
FORD CHASSIS
MOTORHOMES**

Dear Customer:

Your new Banks PowerPack® is a unique combination of air intake and exhaust components designed to make the most of your engine's power potential. By removing intake and exhaust restrictions, providing cooler intake air, and tuning the exhaust to create a scavenging effect, your engine can produce more power at a higher level of efficiency. If your driving habits remain the same, your fuel mileage should go up, and you can run on the same octane fuel you are accustomed to using.

If you have any questions concerning the installation of the Banks PowerPack® kit, please call Gale Banks Engineering at (626) 969-9600 between 8:00 am & 5:00 pm (PT) and ask for the service department.

Thank you.

GENERAL INSTALLATION PRACTICES

1. For ease of installation and trouble-free operation of your BANKS PowerPack®, PLEASE READ THIS 16-PAGE INSTRUCTION PACKAGE BEFORE STARTING ANY WORK. (If any pages are missing from this package, please call GALE BANKS ENGINEERING immediately for a replacement.) Become thoroughly familiar with all components and phases of the installation before starting any work.

2. Inspect all components supplied for any foreign material that may have entered during shipping and handling.

CAUTION: Whatever methods are used to elevate the vehicle must be of sufficient capacity for the vehicle weight involved. NEVER work under any vehicle supported only by a jack of any kind. DO NOT USE concrete blocks or other masonry items that may collapse under the vehicle weight.

3. Pay particular attention to the routing of any wires. Keep them away from exhaust heat, moving parts and sharp edges that may cause cuts or other damage. Route or tie wires away from critical areas as required. Keep all wires a minimum of 6"

from hot exhaust parts, 8" or more is recommended whenever possible.

4. Right-hand and left-hand designations refer to the driver's right or left, as seated in the vehicle, (i.e.: Right-hand refers to the passenger side of the vehicle, unless noted otherwise.)

5. The Banks Motorhome PowerPack is designed to fit Class "A" 460 Ford chassis combinations. Because of different equipment layouts used by various coach builders, some accessories and components may have to be relocated to accommodate the air intake components of the Banks PowerPack.

Notification

The Banks Ram-Air Filter comes pre-oiled and no oiling is necessary for initial installation. Service the filter as specified in the Cleaning and Oiling the Banks Ram-Air Filter Section of this manual.

FACTORY EXHAUST MANIFOLD BOLT REMOVAL

Because of a condition inherent in the factory design, the exhaust manifolds may crack the manifold-to-head bolts as manifolds undergo changes in length from expansion and contraction. In some cases, these forces may also crack the exhaust bolt bosses on the cylinder head. Cracked bolts will not show any external damage, but bolt heads may break off upon removal.

1. ***We recommend that you do the following to minimize the possibility of broken manifold bolts.***

2. Apply a penetrating oil (such as Liquid Wrench) to the area where each exhaust manifold bolt enters the cylinder head.

3. If some bolts turn more easily than others, remove these bolts first. This may reduce stress on the tighter bolts.

The use of an impact wrench is recommended, when available. The hammering action of the impact tool helps loosen the bolts better than the steady pull of a wrench handle.

If a manifold bolt does break off, it may be removed by one of the following methods.

1. If there is enough thread remaining on the broken bolt to install two nuts, it may be possible to jam the nuts together to turn the bolt. Tighten the nuts against each other, then turn the bolt by turning the inner nut counterclockwise.

2. If there is some thread protruding from the head, but not enough to install double nuts, it may be possible to grip the bolt with a tool such as a Vise-Grip pliers.

3. If the bolt has broken off near or below the flange surface of the head, it may be drilled and removed with a screw extractor, such as an Easy-Out. Make sure you drill the pilot hole in the center of the broken bolt with the proper size drill for the extractor used. If the hole is not on center, it may cause the extractor to bite into the threads in the head, preventing the extractor from turning.

For severe cases, a bolt extractor kit may be ordered from Gale Banks Engineering (P.N. 97000).

INSTALLATION INSTRUCTIONS

FIGURE 1

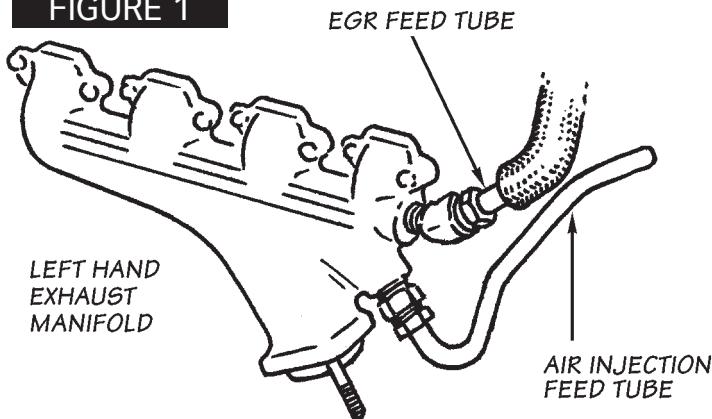
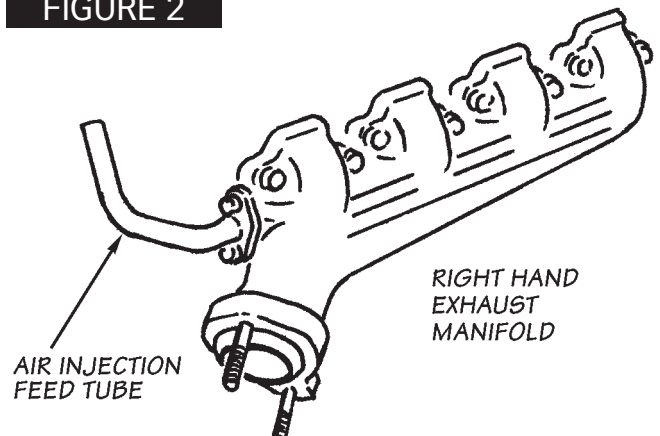

FIGURE 2



1. Remove the "dog house" cover from the engine for access.
2. If a heavy duty hoist is available, raise the vehicle and remove the front wheels for easier access. If the rear wheels remain on the ground, block the rear wheels.
3. Disconnect all cables from the battery(s).
4. Starting from the rear of the vehicle and working forward, remove the exhaust system from the vehicle. Disconnect oxygen sensor wire at oxygen sensor plug (plug is located about two feet up the wire loom). Leave exhaust pipe hangers in place on the chassis. Remove headpipe assembly from exhaust manifolds.
NOTE: Some joints may require the heat from a torch to loosen them for disassembly.
5. Disconnect sparkplug wires at sparkplugs. Label wires to assist in reinstallation.
6. Remove sparkplug heat shields.
7. Disconnect EGR valve feed tube from elbow fitting at rear of left hand exhaust manifold. A 1¹/₁₆" tubing wrench may be required (Snap On No. RX34), and fitting may have to be heated, then sprayed with WD40, or similar lubricant to assist in removal from the exhaust manifold. **See Figure 1.**
8. The air injection feed tube for each factory exhaust manifold must also be disconnected at the factory exhaust manifolds. Use the same heating and lubrication procedure described in **step 7.** (See **Figures 1 and 2**)
9. Remove exhaust manifolds from engine. Unbolt ignition coil bracket, emissions control bracket and dipstick tube bracket as required.
10. If the main positive power cable (large red battery cable) crosses over from the frame

to the starter motor adjacent to the exhaust manifold area, disconnect it at the stud on the starter motor. Re-route the cable to the starter motor by feeding the cable between the side engine mount and the oil pan. Cut the plastic cable ties on the forward part of the cable bundle as required to provide slack as needed for the new cable routing. Reconnect the cable at the starter motor.

NOTE: Not all installations will require this. If the battery cable does not cross over from the frame to the starter adjacent to the exhaust manifold area, this step may be omitted. See step 16.

11. Remove fabric heat shield material from frame that is adjacent to the left side of the engine, if equipped. (Many motorhome chassis do not have this shield.) Unbolt the left front spring bump stop bracket (located directly above the front axle) from the bottom of the frame rail. Reinstall the bump stop bracket while bolting the brake line heat shield supplied in the PowerPack kit under the nuts securing the bracket to the frame rail (**see Figure 3**). Install a 1/4"-28 x 1" hex bolt, two SAE washers and a 1/4"-28 locknut through the heat shield and into a corresponding hole on the engine mount bracket.
12. Inspect the cylinder head exhaust flange surfaces. Remove any loose carbon, rust, old gasket material, etc. as required to provide a clean, flat manifold mounting surface.

NOTE: The Banks PowerPack® exhaust manifolds feature a heavy duty machined flange that is designed to bolt directly against the cylinder head without the necessity of gaskets, which are prone to deteriorate and blow out in time. In some instances the factory cylinder head flange surfaces may have become excessively eroded from leaking factory exhaust manifolds such that the Banks manifolds will not seal to the head. In these instances gaskets will have to be installed between the head and manifold to provide a seal.

FIGURE 3

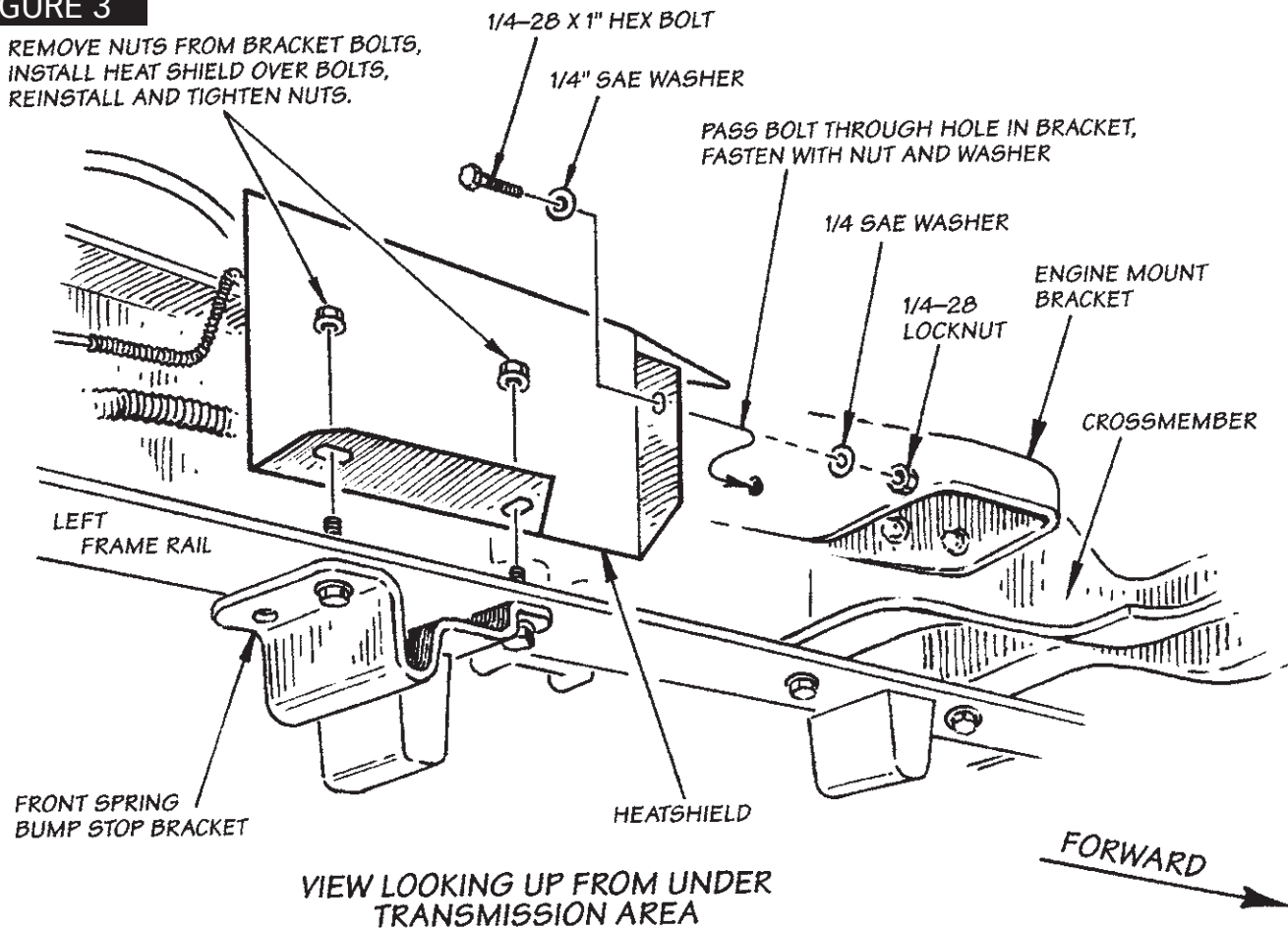

13. Bolt the Banks exhaust manifolds to the cylinder heads while noting the following items:

NOTE: It may be necessary to turn front wheels all the way to the left to provide installation clearance.

A. Three different bolt lengths are utilized. Refer to **Figures 4 and 5** for bolt locations.

NOTE: Due to the heat soaking characteristics of cast manifolds, spark plug heat shields are required in the factory application. Banks TorqueTubes, however, do not retain heat in the tubes. Therefore, the spark plug heatshields are unnecessary, and in some cases may cause engine misfire due to deterioration of the shield insulation. We recommend that the factory heat shields not be reinstalled with the TorqueTubes. Instructions are provided, however, to allow for reinstallation should you decide to do so. The tabs that attach the spark plug boot heatshields must be bent to line up with the bolt holes in the manifold flange. Adjust the tabs as required so spark plugs may be serviced. End tabs on some heat shields may not line up with bolt holes. In this case use center mounting tabs only.

B. Spacers are used with some bolts to mount the ignition coil bracket, emissions control bracket and heat shield. Bend the mounting tabs for these components to line the tabs up with the manifold and spacer bolt holes. The dipstick may be bent slightly as needed to clear the manifold tube. Be careful not

to kink the dipstick tube.

C. Because of the tight confines, we suggest that the EGR tube and air injection tube (if equipped) be tightened into the manifold with the manifold loosely attached to the head (this allows for some additional freedom of movement). In some cases, the EGR and air injection tubes may have to be tightened with the manifold completely separated from the head, then bolted to the head when wrenching the tubes is completed. Air injection tube may be loosened from its upper support bracket to aid in alignment during installation. A dab of anti-seize on the tube threads will aid in assembly.

Once this procedure is complete, install remaining manifold bolts with anti-seize applied.

14. Reconnect the EGR valve exhaust feed tube and air injection tube to the bungs on the left-hand PowerPack[®] exhaust manifold. Feed tubes may be bent slightly if needed. A light lubricant or Anti-Seize on the threads eases installation.

Important! Some motorhomes may have the transmission shifter cable and in some cases the speedometer cable routed near the left (driver's) side TorqueTube manifold, exposing them to heat. This routing will vary depending on the coach manufacturer, but it is important to protect these cables from heat in any case.

Wrap one piece of the 3 x 16" foil heat shield blanket around the shifter cable where the cable crosses

FIGURE 4

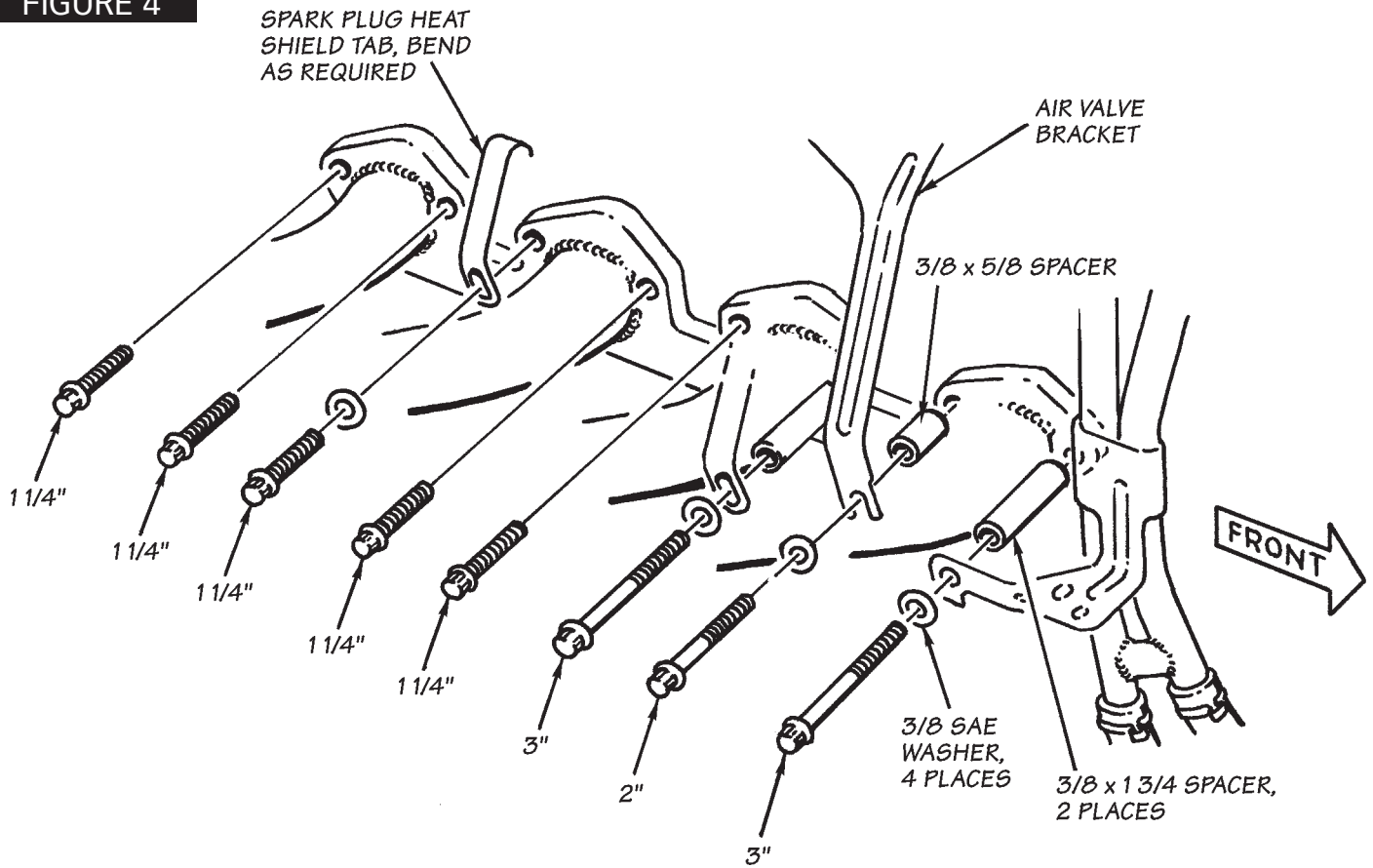

FIGURE 5

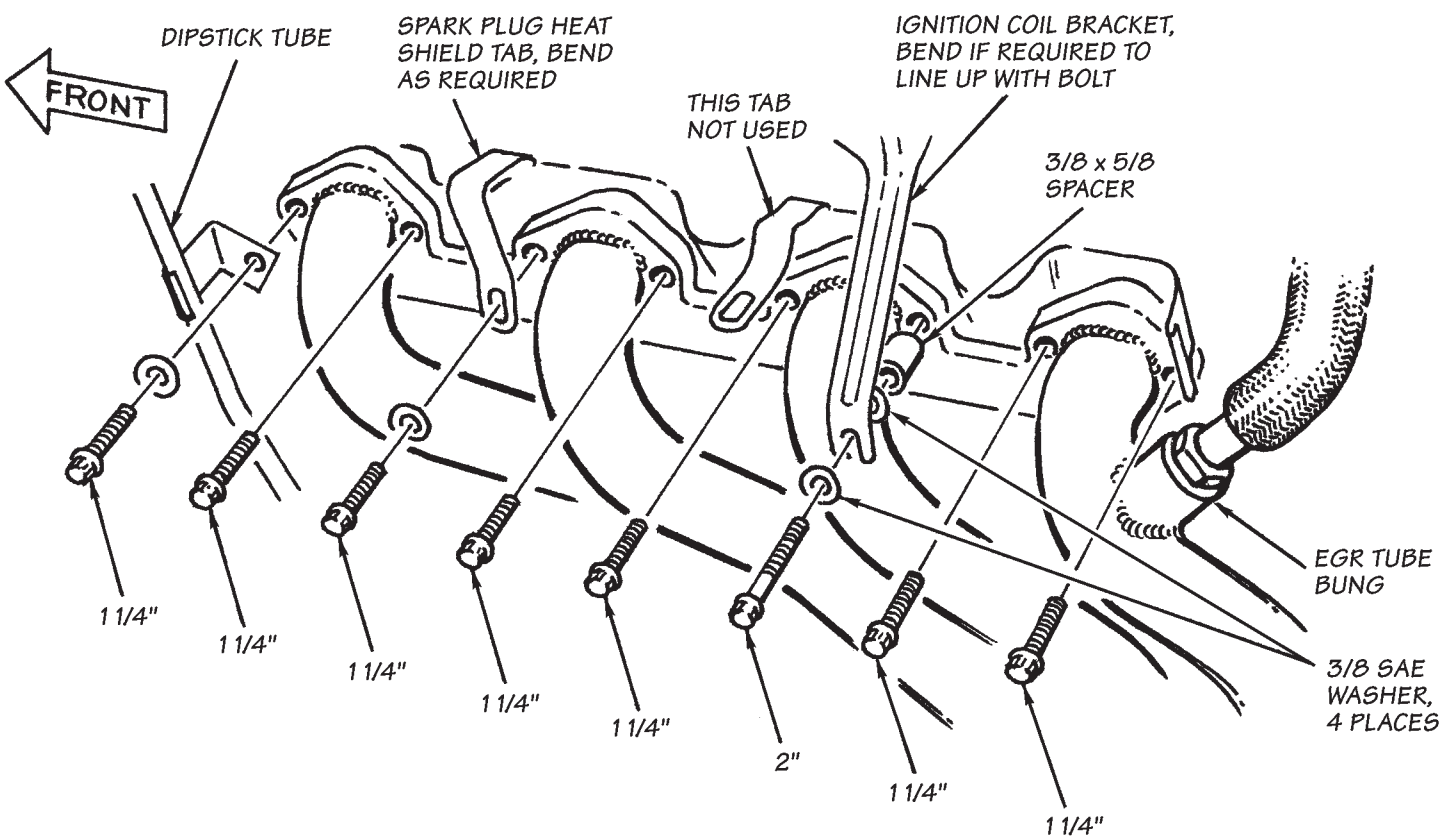
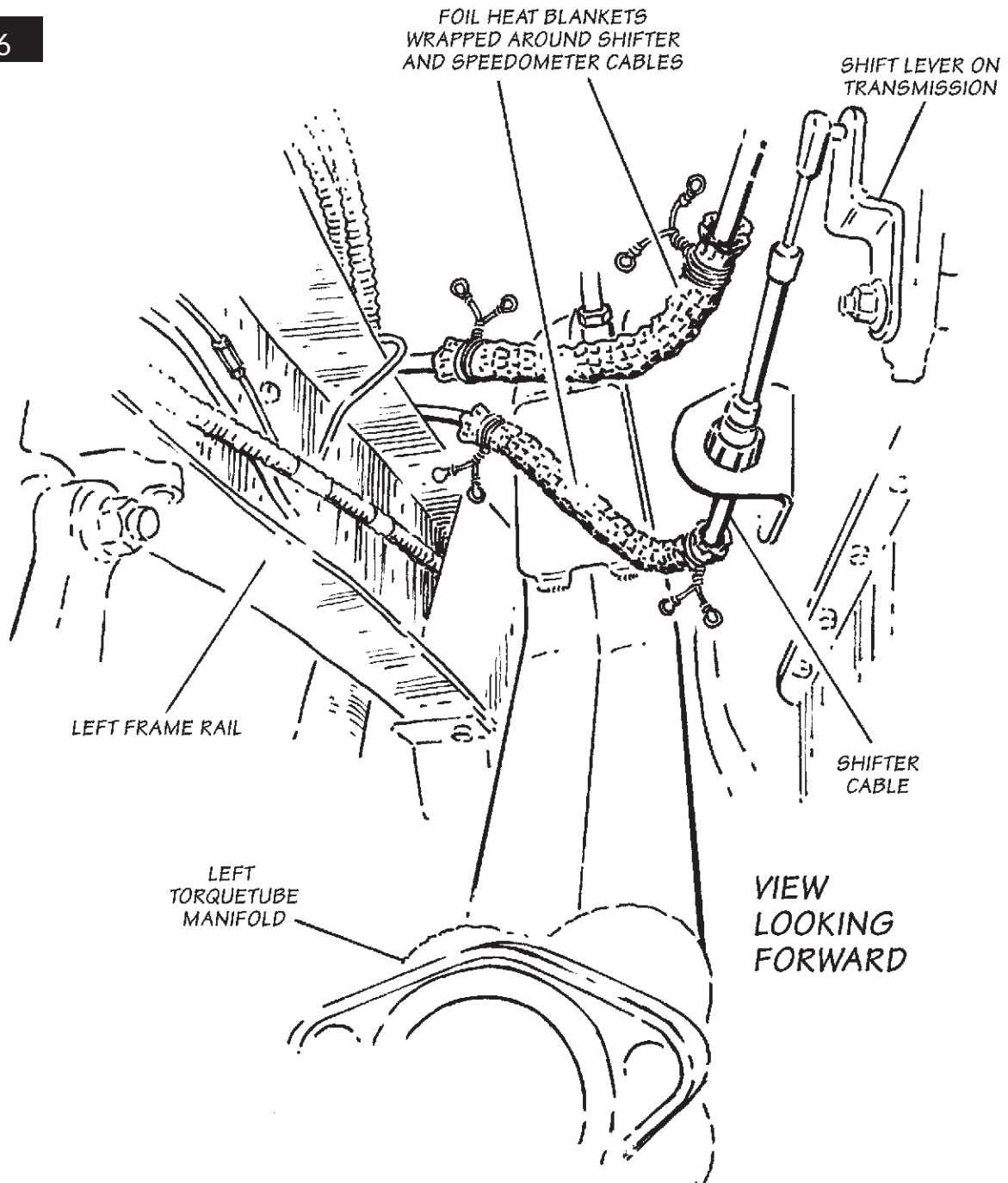

FIGURE 6

from the transmission to the frame rail in the proximity of the exhaust manifold. Secure the heat shield in place with the wire ties provided. Cut the remaining wire off, making sure that the sharp wire ends will not chaff the cable in any way.

If the speedometer cable is also routed near the exhaust manifold, wrap it with the second piece of foil heat shield blanket, securing it with the wire ties provided. **See Figure 6.**

15. Reconnect air injection tube (if used) to two-bolt flange at rear of right exhaust-manifold head flange. (Only manifolds for air injected engines will have this flange.)

Use new gasket, provided, two $\frac{5}{16}$ -24 x $\frac{5}{8}$ hex bolts, and four $\frac{5}{16}$ " circle-lock washers. Washers are used in pairs on each bolt, the ramps on the surface of each washer must face each other when installed on

bolt. **See Figure 7** for proper washer installation.

16. Check that the positive battery cable to the starter motor has at least three inches of clearance to any part of the exhaust manifold tubing. Also check that the cable will not rub on any sharp edges that could cut through the insulation and cause a short. Reposition or tie the cable in place to correct any of these conditions.

17. Install spark plugs and reconnect plug wires.

18. Install the starter heatshield by first slipping the No. 56 hose clamp through the slots in the heatshield as shown in **Figure 8**. Now, with the heatshield between the TorqueTube exhaust manifold and the starter, feed the tail of the No. 56 hose clamp between the solenoid and starter motor, then tighten.

FIGURE 7

**AIR INJECTION CONNECTION
AT REAR OF RIGHT-HAND
EXHAUST MANIFOLD**

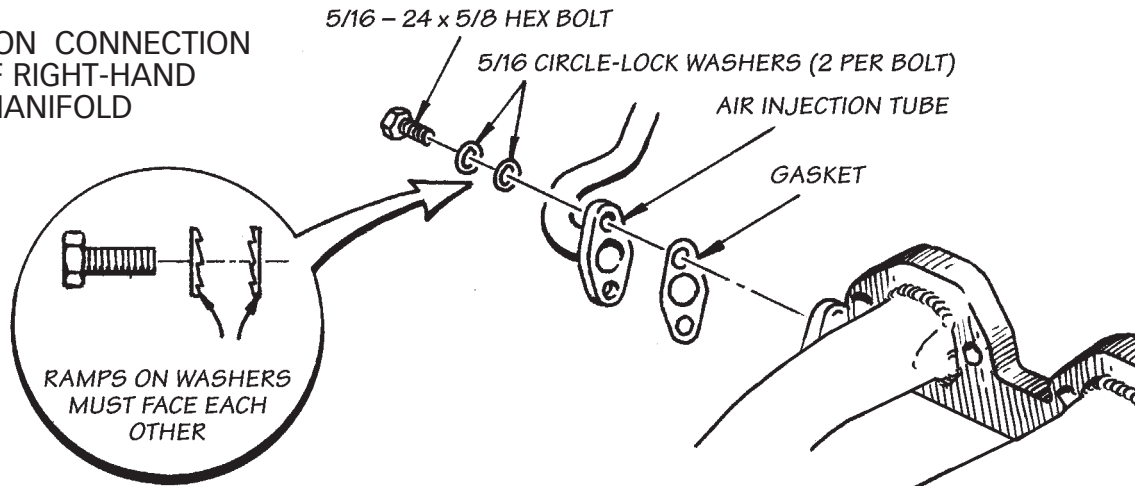

19. Install the Banks Y-pipe assembly to the exhaust manifolds using four $\frac{3}{8}$ -16 x 2" hex bolts, four $\frac{3}{8}$ SAE washers and a 2 $\frac{1}{2}$ " U-clamp. Use two doughnut gaskets, provided, between the manifold outlets and Y-pipe flanges. **See Figure 9.** Rotate the flanges to provide clearance to the oil pan and lower bolt of spring shackle.

20. Install the small, straight-thru primary muffler to Y-pipe. Use 3" U-clamp. Install hanger rod on Y-pipe into factory hanger.

21. Carefully remove the oxygen sensor from the original head pipe assembly and reinstall in the Y-pipe. Reconnect oxygen sensor to wiring using the extension cable assembly provided. Install cable clamps on transmission pan as shown in **Figure 10.** Make sure cable is routed and tied as far away from exhaust piping as possible. **See Figure 10** for routing.

NOTE: Some motorhome chassis use an oxygen sensor with a slightly different plug that will not mate with plug on the Banks extension cable. On these vehicles, file the two plastic index pins off of the outside of the plug on the oxygen sensor. Then file the index pins off of the plug on the extension cable that mates with the factory wire loom. The plugs should now mate together properly.

22. Install 28" intermediate pipe in outlet of primary muffler. Install 3" U-clamp to secure pipe in muffler. Install 3" hanger clamp on intermediate pipe to support muffler. **See Figure 9.**

23. The Ford Class "A" Motorhome chassis is supplied in several wheelbase lengths. The standard length is 178" wheelbase. Longer wheelbase coaches will require an additional extension pipe. These are available from Gale Banks Engineering in a 33" and 53" length to fit 208" and 228" wheelbase coaches, respectively. Other wheelbase coaches may be accommodated by cutting one of these two extension pipes.

Extension pipes are required to fit wheelbase lengths as follows:

- A.** 178" wheelbase
No additional extension pipe required (use 28" extension pipe supplied in all kits).
- B.** Up to 208" wheelbase
Requires 33" additional extension pipe.
- C.** Up to 228" wheelbase
Requires 53" additional extension pipe.
- D.** Up to 258" wheelbase
Requires 33" and 53" extension pipes.

Install the appropriate additional extension pipe(s) if required. Wheelbases other than 208 or 228 inches will require that the extension pipe be shortened. Add additional 3" hanger clamps (available from Gale Banks Engineering) as required to support extension pipes in factory rubber hangers.

24. Install the secondary muffler on the intermediate pipe or extension pipe. Support rear of muffler with muffler hanger U-clamp provided. **See Figure 11.** Do not tighten hanger clamp at this time. Install, but do not tighten 3" U-clamp at muffler inlet connection.

25. Install tailpipe over rear axle and into muffler outlet connection. Insert tailpipe hanger pin into factory rubber hanger. Rotate secondary (rear) muffler as required to best align muffler with tailpipe and intermediate pipes. Once alignment is determined, tighten clamps at muffler inlet and outlet connections. Hanger clamps on intermediate piping may be loosened and readjusted if necessary. **See Figure 11.**

26. Install intermediate pipe heatshield on intermediate pipe between primary and secondary mufflers. Heatshields install with the shield above the pipe, to protect the coach floor. Because the location of factory pipe hangers will vary, the installer must provide a notch in the heat shield to clear the hanger rod on the U-clamp hanger. **See Figure 12.** Make two saw cuts through the folded lip of the heat shield, one inch into the flat section beyond the fold

FIGURE 8

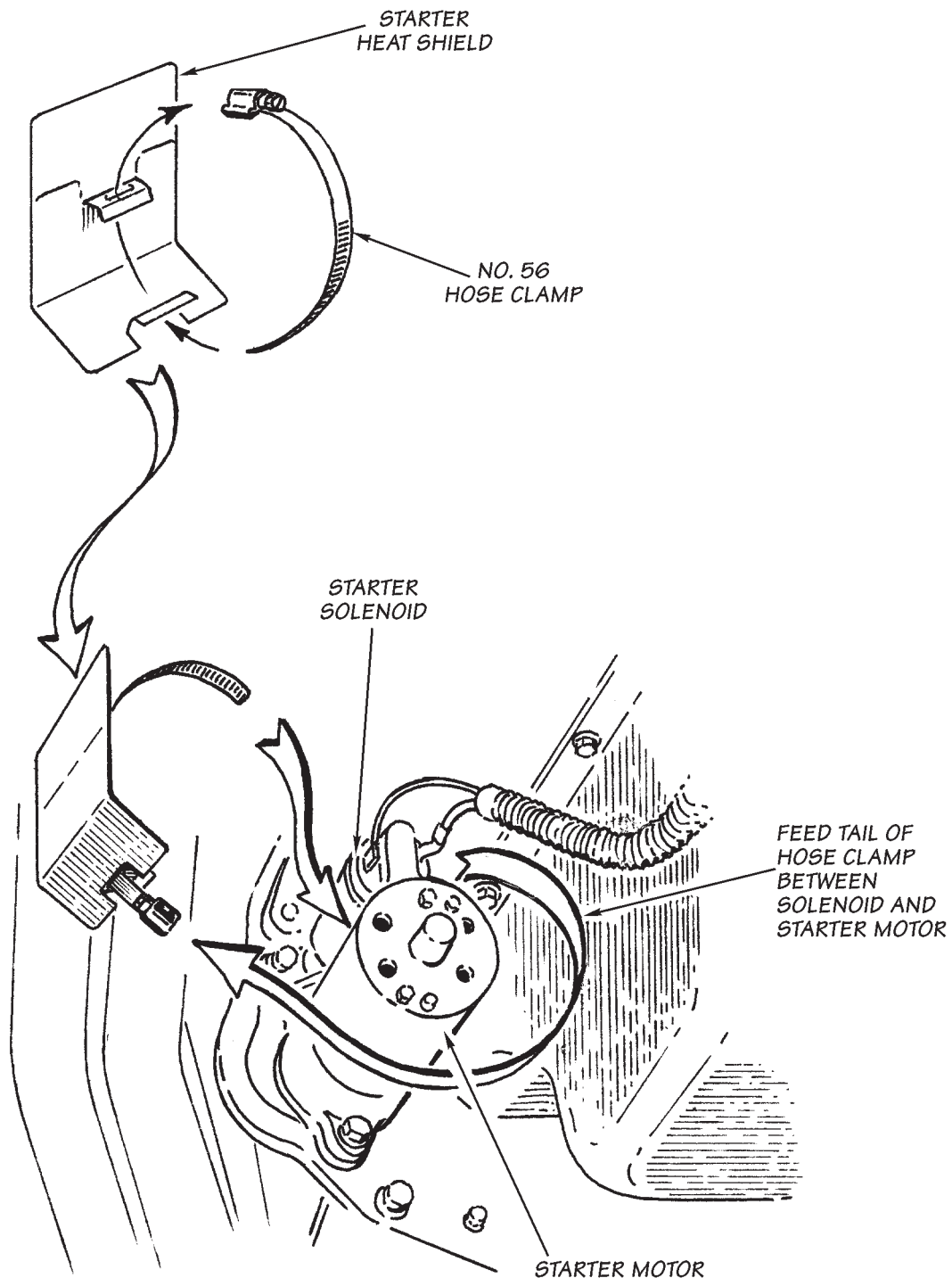

line. Locate the cuts either side of the hanger rod location. Fold the metal between the cuts back against the flat portion of the shield to provide a clearance notch for the hanger rod. Loosely clamp the 3" U-clamps to the intermediate pipe so that they can be positioned to line up with the slots in the heat shield as shown in **Figure 12**. With the proper positioning of the U-clamps determined, remove the heat shield and tighten the U-clamps. Once this is completed, install the $\frac{3}{8}$ " SAE washers, heat shield, and $\frac{3}{8}$ "-16 flange nuts. **See Figure 12.**

27. If an extension pipe has been installed between the intermediate pipe and the secondary muffler, an additional heat shield will have been provided with the optional extension pipe. Overlap this heat shield with the heat shield on the intermediate pipe as shown in **Figure 12**. Mount the shield so the forward end covers the slip joint where the extension pipes join. If the extension pipe had to be shortened for a shorter wheelbase, overlap the heat shield so that it will cover the slip joints at each

continued on page 12

FIGURE 10

CLAMP OXYGEN SENSOR LEAD TO TRANSMISSION PAN WITH CABLE CLAMP SUPPLIED. SECURE TO TRANSMISSION WITH ONE EXISTING PAN BOLT.

REMOVE INDEX PINS FROM PLUGS

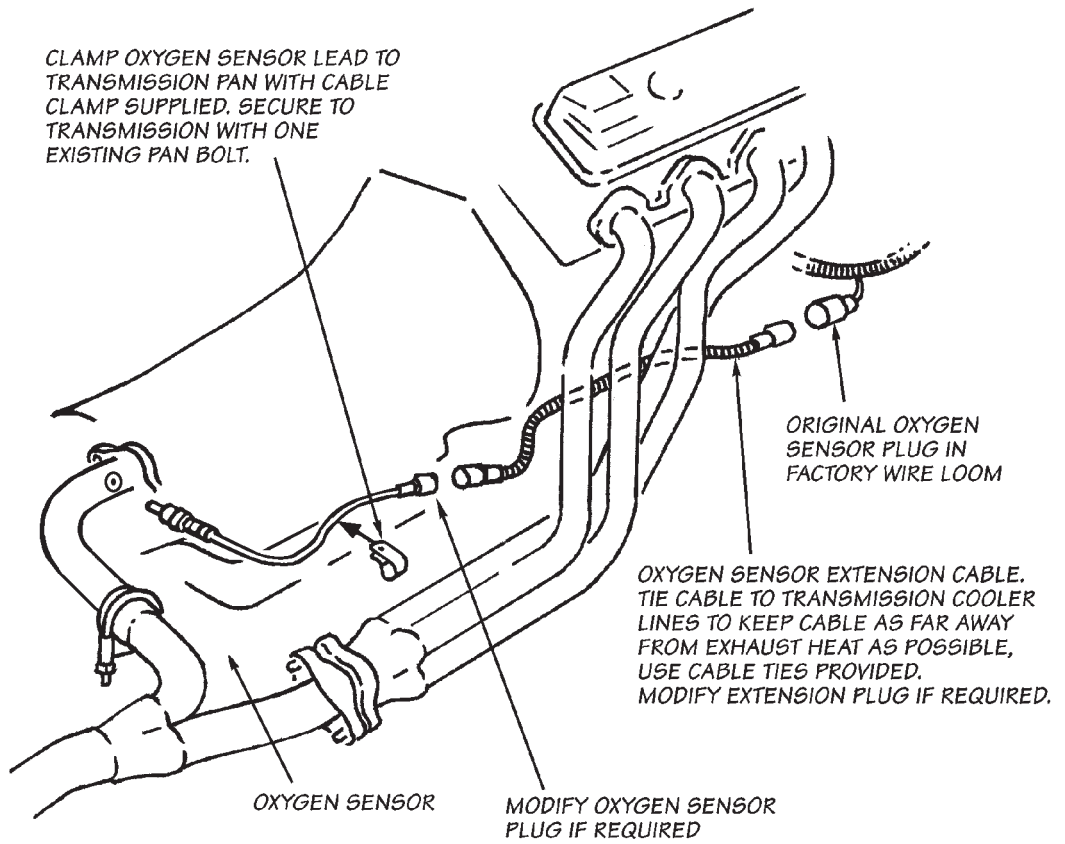
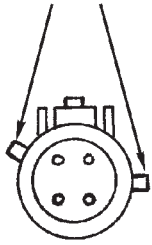

FIGURE 11

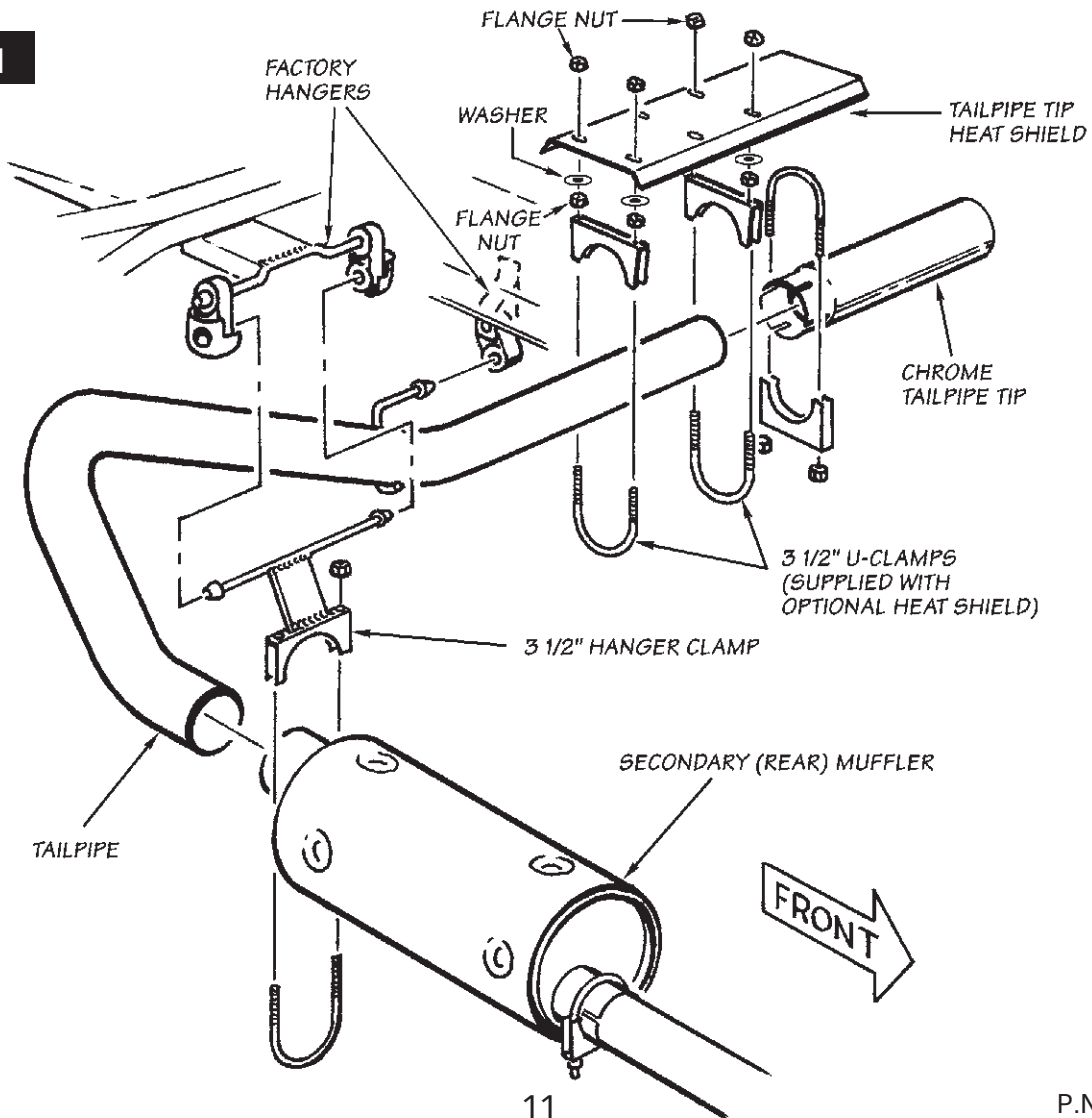
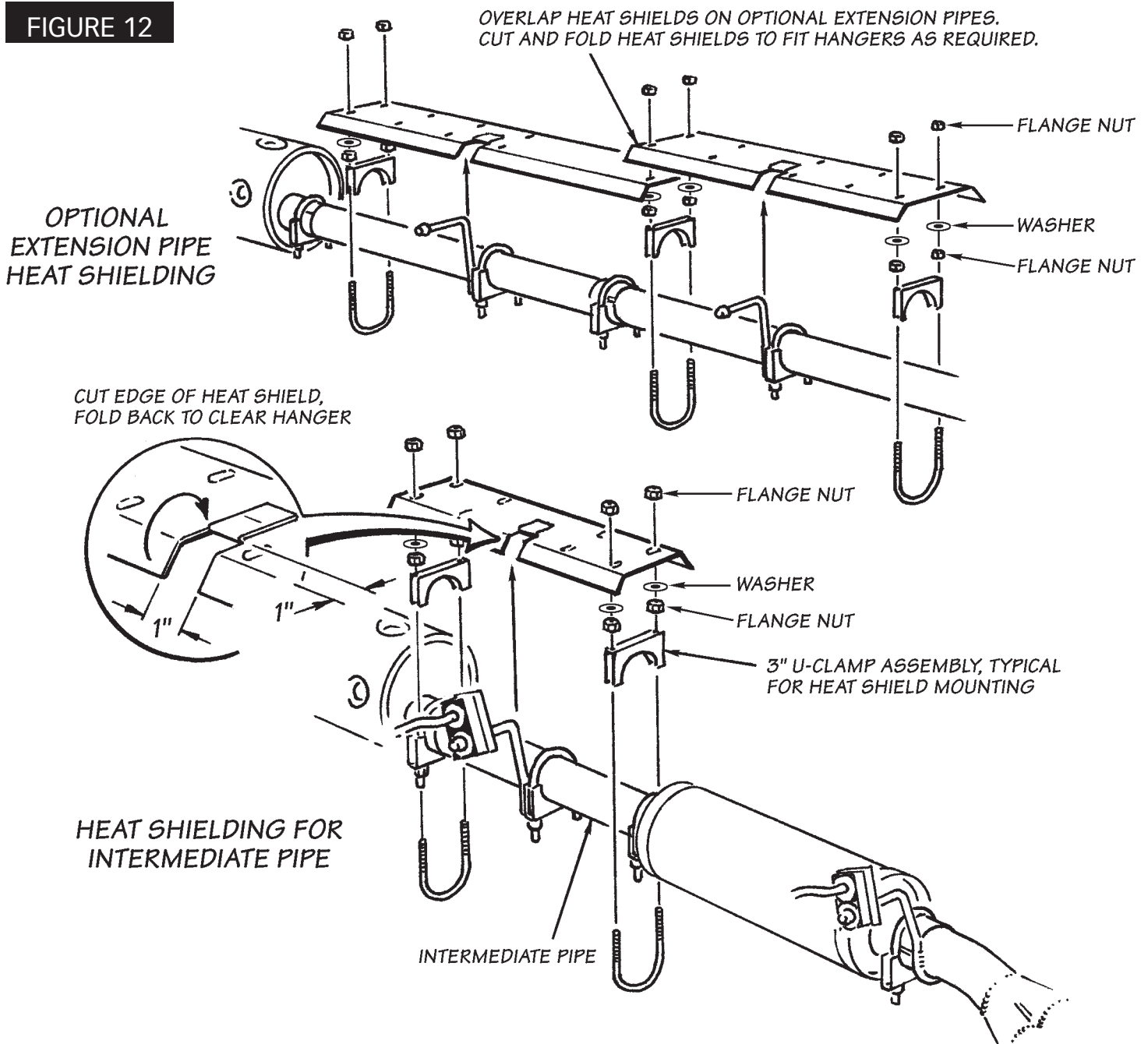

FIGURE 12



end of the extension pipe. The long heat shield has clamp holes every few inches to allow the shield to be positioned over as much pipe length as possible when installed. **See Figure 12.** Cut notches as required to clear hanger rods.

28. Install the chrome tailpipe tip and chrome tailpipe heat shield assembly on the tailpipe as shown in **Figure 11.** The heat shield should be installed in the same fashion as mentioned in the preceding steps. Tip may be slid in or out on the tailpipe to match the body width. If the tailpipe must be shortened to position the tip near the coach body, cut the tailpipe to place it 1 to 2 inches within the outside end of the tailpipe tip. This will minimize any heat discoloration of the chrome plating on the tailpipe tip. The chrome tip is provided with a single 3 1/2" U-clamp for mounting.

BANKS RAM-AIR SYSTEM

The Banks PowerPack cold air induction components are designed to extend the factory air intake path so that cooler outside air can be picked up from directly behind the vehicle's grille. These components include a molded Banks Super-Scoop™, 4" diameter flexible tubing, Ram-Air Filter Cover and installation hardware. **Figure 13** shows a typical hook-up of the air intake components as they tie to the factory system. The Super-Scoop also serves as a water separator to drain out any rain water that may enter through the grille.

The Banks PowerPack cold air induction package is intended to fit a number of motorhome body configurations. Because each coach builder has a different layout of behind-the-grille components, there can be no one set installation procedure for the Banks Ram-

Air package. The following instructions are intended as a guideline for installing the Ram-Air system. Also, some coach builders may have installed difficult to relocate components (such as air conditioning freon piping or heater hoses) in the areas where the Banks Ram-Air is normally mounted. In these cases, the installer will have to find an alternate location for the Ram-Air components, or omit these pieces that are impossible to mount.

29. Remove the air cleaner housing cover. Replace the factory paper element and filter cover with the Banks Ram-Air filter element and cover. Use new 6mm x 40mm bolts, don't over tighten.

30. Determine a location for the Banks Super-Scoop. It should be placed as low as possible directly behind the grille, with the air inlet opening pointing straight ahead. If the grille is at an angle, the Super-Scoop should be trimmed at an angle, whenever possible, to place the air inlet opening against the back side of the grille with the centerline of the inlet opening horizontal. **See Figure 13.** Use heavy snips or a hacksaw to trim the air inlet opening of the Super-Scoop. The height between the Super-Scoop and the air inlet hood should be as great as possible to prevent any rain water not eliminated by the Scoop's water drain hole from climbing up into the air filter. The curved outlet section of the Super-Scoop may be trimmed back if less bend is required to make a more streamlined hose routing. **See Figure 13.**

31. Once a location has been determined for the Super-Scoop, mount it using one of the methods outlined below.

The Banks Super-Scoop may be mounted by several means. If the grille consists of horizontal bars or a perforated metal screen heavy enough to support the inductor, it may be secured using four 14" nylon cable ties, provided, slipped through the ears on the Scoop and through the grille. **See Figure 14.**

An alternate method is to mount the inductor using the four perforated metal straps provided. These can be bent as required and attached to the Scoop's ears with the 1/4" 20 x 1 1/4" hex bolts, 1/4"-20 nylock nuts and 3/4" O.D. x 5/16" I.D. flat washers provided. The opposite end of the straps may be attached to any convenient mounting points such as the gravel pan, grille brackets, etc. as required, with four No. 10 x 3/4" sheet metal screws provided. A combination of cable ties and scraps may also be used.

Connect the fresh air inlet on the air filter housing to the Super-Scoop using the 4" diameter flex hose provided. Cut the hose to the desired length using a knife and diagonal cutting pliers. Secure with No. 64 hose clamps.

32. Check over the entire installation for loose clamps or bolts, hoses and wiring too close to hot or moving parts, sharp edges, etc., and correct as necessary.

33. Reconnect battery cables. Reinstall engine "dog house" cover. Remount tires, if removed.

FIGURE 13

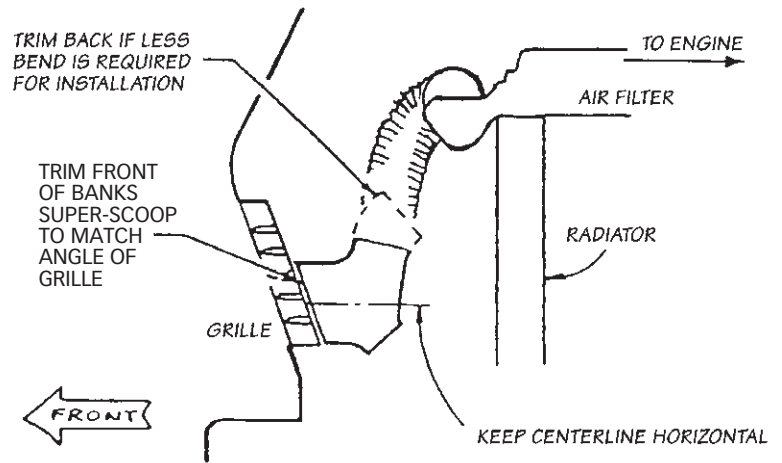
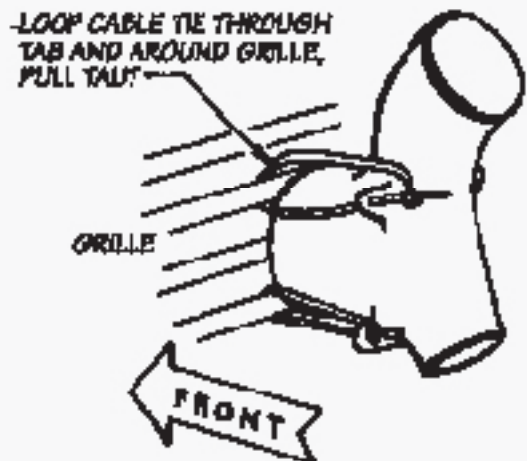

FIGURE 14

CABLE TIE MOUNTING



STRAP MOUNTING

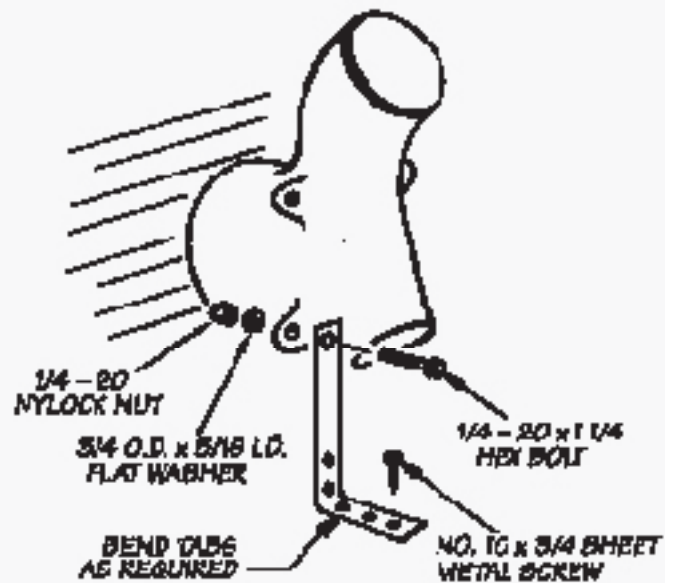
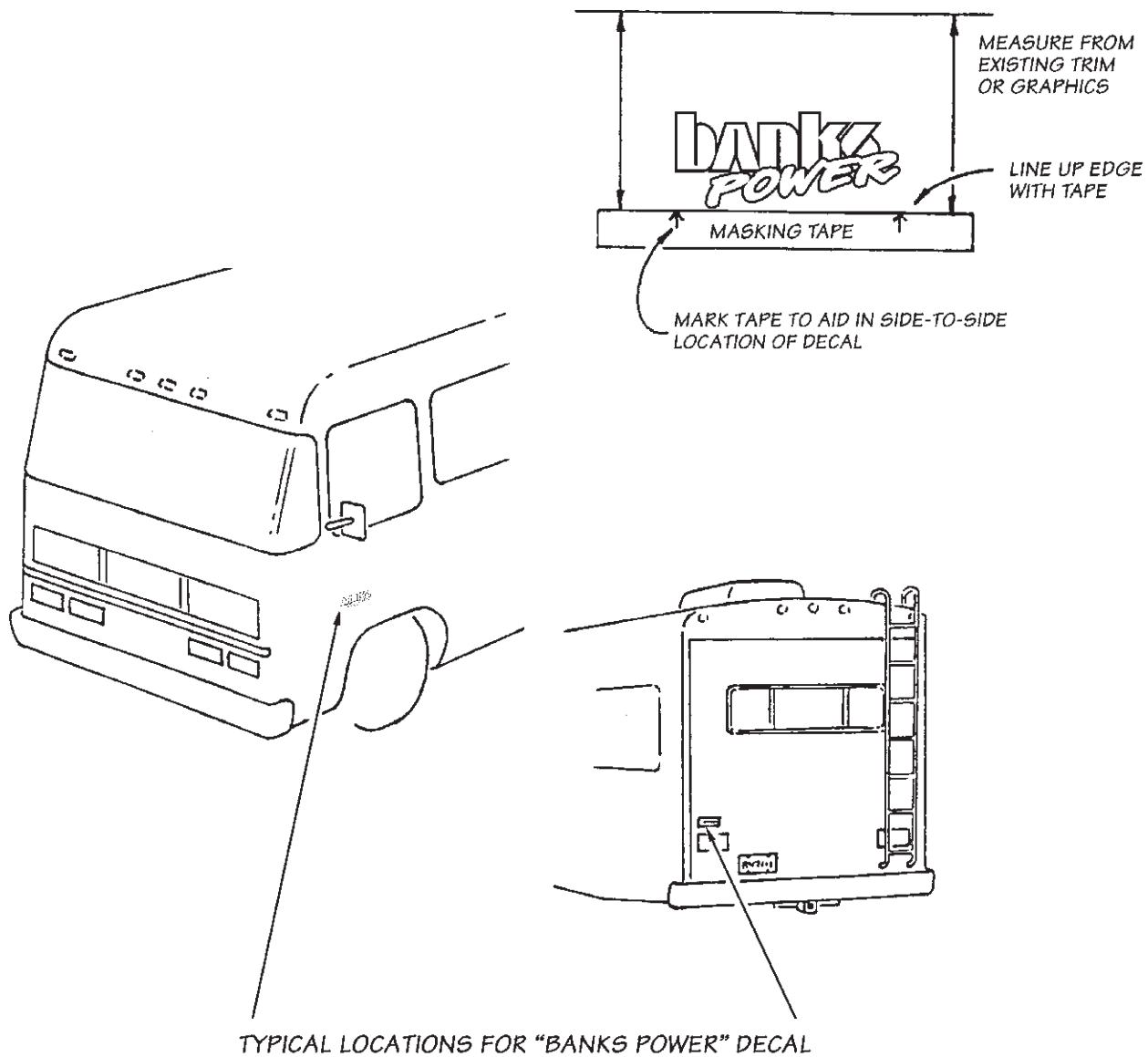

FIGURE 15



34. Start engine and listen for any exhaust leaks. Tighten bolts or clamps to correct leaks as required. Allow engine to warm up and test drive vehicle.

NOTE: Exhaust tubing will smoke for the first 15 to 20 minutes of operation. This is normal, as grease used in the bending process will burn off the inside of the pipes.

35. Three Banks PowerPack® plaques have been included in your kit. These may be affixed to your vehicle by peeling off the backing and pressing firmly in the desired location. A piece of masking tape applied to the vehicle with reference measurements to other emblems or body trim may be used to level and locate your plaques. **Figure 15** shows suggested locations for plaques.

36. For California vehicles, apply the CARB sticker, supplied, to an under-hood location near other tune-up information.

CLEANING AND OILING THE BANKS RAM-AIR FILTER

Notification

The Banks Ram-Air Filter comes pre-oiled and no oiling is necessary for initial installation. Use Banks Ram-Air Filter cleaning system (part #90094), available from Gale Banks Engineering to service the Air Filter. Follow the instructions included with the cleaning system to clean and re-oil your Banks Ram-Air Filter.

1. PRE-CLEANING

Tap the element to dislodge any large embedded dirt, then gently brush with a soft bristle brush. NOTE: If complete cleaning is not practical at this time, reoil the element and reinstall in your vehicle.

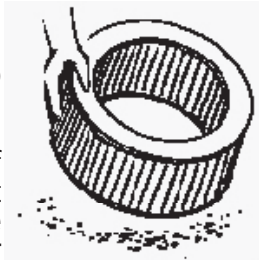

2. SPRAY-ON CLEANING

Spray Banks air-filter cleaner liberally onto the entire element and let soak for 10 minutes.

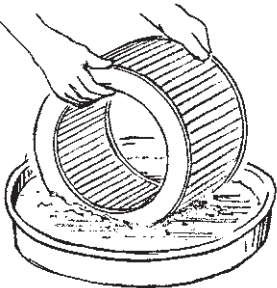
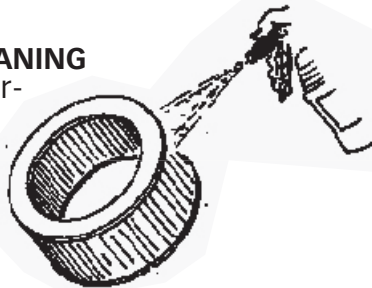

PAN CLEANING

Large air-filter elements can be rolled or soaked in a shallow pan of Banks air-filter cleaner. Remove immediately and let soak for approximately 10 minutes.

3. CLEANING HINTS

Use only Banks air-filter cleaner. NO gasoline cleaning, NO steam cleaning, NO caustic cleaning solutions, NO strong detergents, NO high-pressure car wash, NO parts cleaning solvents. Any of these NOS can cause harm to the cotton filter media plus SHRINK and HARDEN the rubber end caps.

4. RINSE OFF

Rinse off the element with low-pressure water. Tap water is okay. Always flush from the clean side to dirty side. This removes the dirt and does not drive it into the filter.

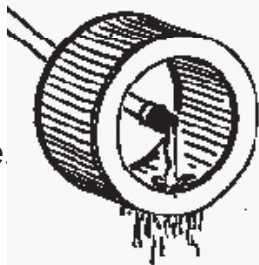

5. DRYING HINTS

Always dry naturally. After rinsing, shake off all excess water and let the element dry naturally. DO NOT USE COMPRESSED AIR – DO NOT USE OPEN FLAME – DO NOT USE HEAT DRYERS!

EXCESS HEAT WILL SHRINK THE COTTON FILTER MEDIA. COMPRESSED AIR WILL BLOW HOLES IN THE ELEMENT.

6. AEROSOL OILING

After cleaning air filter always reoil before using. Spray Banks Ram-Air filter oil down into each pleat with one pass per pleat. Wait 10 minutes and re-oil any white spots still showing.

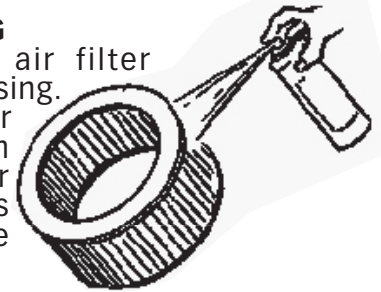

7. OILING HINTS

Never use a Banks Ram-Air filter without oil (the filter will not stop the dirt without the oil). Use only Banks Ram-Air filter oil. Banks air-filter oil is a compound of mineral and animal oil blended with special polymers to form a very efficient tack barrier. Red dye is added to show just where you have applied the oil. Eventually the red color will fade but the oil will remain and filter the air. NEVER USE Automatic Transmission Fluid. NEVER USE Motor Oil. NEVER USE Diesel Fuel. NEVER USE WD40, LPS, or other light-weight oils.

8. REINSTALL

Reinstall your Banks Ram-Air filter element with proper care. Make sure the element seats properly in the filter case. Install the cover making sure it's in the right position. Tighten all the nuts, bolts, screws or clips to factory specifications.

9. DO NOT DISCARD

Affix the "Do Not Discard" sticker to the filter case (included with every Banks replacement element). Make sure you put the sticker in a highly visible place to alert your mechanic not to discard.

10. PERFORMANCE HINTS

Service every 50-100,000 miles on street-driven applications. Service more often in offroad or heavy-dust conditions. If an air-filter restriction gauge is installed, then change the element when the air-filter restriction reaches 18"/H₂O.

CAUTION! Extremely fine dust from agriculture or offroad use will pull the oil from the element. Frequent reoiling of the element's clean side might be required. Completely service when practicable. For extra protection use an air-filter sealing grease on rubber ends of the element. Service only with Banks air-filter cleaner and Banks air-filter oil.

BILL OF MATERIALS

Ford 460 EFI Class-A Motorhome PowerPack System

COMPONENT	PART#
ASSEMBLY, Hanger Clamp, 3"	52694
ASSEMBLY, Hanger Clamp, 3 1/2"	52695
BOLT, 1/4-28 x 1", Hex	91140
(4) BOLT, 3/8" 16 x 2", Hex	91466
(2) BOLT, 5/16" 24 x 5/8"	91251
(12) BOLT, Manifold, 3/8" 16 x 1 1/4", 12 point	91952
(2) BOLT, Manifold, 3/8" 16 x 2", 12 point	91953
(2) BOLT, Manifold, 3/8" 16 x 3", 12 point	91955
CARD, Product Registration	96392
CLAMP, Cable, 1/2" dia. x 5/16" hole	62070
CLAMP, Exhaust, 2 1/2", HD-G	52461
(5) CLAMP, Exhaust, 3", HD	52465
(3) CLAMP, Exhaust, 3 1/2", HD	52467
CLAMP, Hose, #56	92857
DECAL, Carb. E.O.-D-161-35	96018
FLANGE, Head Pipe	52343
GASKET, Air Injection Tube	93180
(2) GASKET, Exhaust Outlet	93161
HEAT SHIELD, Brake Line	26069
HEAT SHIELD, Intermediate Pipe	26077
(2) HEAT SHIELD, Speedometer/Shifter Cable	26004
HEAT SHIELD, Starter Motor	26062
HEAT SHIELD, Tailpipe, Chrome	26067
LUBRICANT, Anti-Sieze, 1 oz.	90045
MANIFOLD, TorqueTube Exhaust, Left	52189
MANIFOLD, TorqueTube Exhaust, Right	52190
MUFFLER, Dynaflo, Stainless	52406
MUFFLER, Dynaflo, Stainless, w/Heat Shield	52405
(8) NUT, 3/8"-16, Flange	91420
NUT, 1/4-28, Nylock	91111
OWNERS MANUAL	96344

COMPONENT	PART#
PIPE, 3 1/2" Monster Tailpipe	52693
PIPE, Tailpipe Extension, 4", Chrome	52281
PIPE, Extension, Y-Pipe Assembly	52136
PIPE, Intermediate, 3 x 28"	52673
PIPE, Y-Pipe Assembly	52135
(3) PLAQUE, Banks PowerPack	96008
RAM-AIR SYSTEM	49089
(4) BOLT, 1/4" 20 x 1 1/4", Hex	91119
(4) BOLT, 6mm x 40mm	91760
CARD, Product Registration	96392
(2) CLAMP, Hose, #64	92864
COVER, Filter, Banks Ram-Air	42521
DECAL, Carb. E.O. -D-161-38	96016
DUCT, Air Inlet, Super-Scoop, Banks Ram-Air	42602
FILTER ELEMENT, Banks Ram-Air	41508
HOSE, Air Duct, 4" x 3'	94091
(4) NUT, 1/4" 20, Nylock	91110
(4) SCREW, Sheet Metal, #10 x 3/4"	91840
SERVICE KIT, Air Filter	90094
(4) STRAP, Mounting	42611
(4) TIE, Cable, 15", Black	62003
(4) WASHER, 1/4", USS	91103
(2) SPACER, Exhaust Manifold Bolt, 3/8 x 5/8"	26096
(2) SPACER, Exhaust Manifold Bolt, 3/8 x 1 3/4"	35295
(5) TIE, Cable, 8" Black	62010
(4) WASHER, 5/16", Circle Lock	91205
(2) WASHER, 1/4", SAE	91102
(20) WASHER, 3/8", SAE	91402
WARRANTY STATEMENT	96363
WIRE Extension, O ₂ Sensor	62200
(4) WIRE, Steel Tie, Heatshield	26013