

**OWNERS
MANUAL**
WITH INSTALLATION
INSTRUCTIONS

banks
STINGER

S Y S T E M

TM

FORD 460 EFI CLASS "A" MOTORHOMES
1993-LATER, NON-CATALYTIC CONVERTER

THIS MANUAL IS FOR USE WITH SYSTEM PART NUMBERS 49224

banks

Gale Banks Engineering
546 duggan avenue • azusa, ca 91702
(626) 969-9600 • fax (626) 334-1743

Product Information & Sales: (800) 438-7693
www.bankspower.com

STAGE I STINGER™ FORD 460 EFI ENGINE CLASS "A" MOTORHOMES

Dear Customer:

Your new Banks Stinger™ system is a unique combination of air intake and exhaust components designed to make the most of your engine's power potential. By removing intake and exhaust restrictions, and providing cooler intake air, your engine can produce more power at a higher level of efficiency. If your driving habits remain the same, your fuel mileage should go up, and you can run on the same octane fuel you are accustomed to using.

If you have any questions concerning the installation of the Banks Stinger kit, please call Gale Banks Engineering at (626) 969-9600 between 8:00 am & 5:00 pm (PT) and ask for the service department.

Thank you.

GENERAL INSTALLATION PRACTICES

1. For ease of installation and trouble-free operation of your BANKS Stinger system, please read this entire 12-page owner's manual before starting any work. (If any pages are missing from this package, please call GALE BANKS ENGINEERING immediately for a replacement.) Become thoroughly familiar with all components and phases of the installation before starting any work.

2. Inspect all components supplied for any foreign material that may have entered during shipping and handling.

CAUTION: Whatever methods are used to elevate the vehicle must be of sufficient capacity for the vehicle weight involved. NEVER work under any vehicle supported only by a jack of any kind. DO NOT USE concrete blocks or other masonry items that may collapse under the vehicle weight.

3. Pay particular attention to the routing of any wires. Keep them away from exhaust heat, moving parts and sharp edges that may cause cuts or other damage. Route or tie wires away from critical areas as required. Keep all wires a minimum of 6" from hot exhaust parts, 8" or more is recommended whenever possible.

4. Right-hand and left-hand designations refer to the driver's right or left, as seated in the vehicle, (i.e.: Right-hand refers to the passenger side of the vehicle, unless noted otherwise.)

5. The Banks Motorhome Stinger system is designed to fit Class "A" 460 Ford chassis combinations. Because of different equipment layouts used by various coach builders, some accessories and components may have to be relocated to accommodate the air intake components of the Banks Stinger system.

Notification

The Banks Ram-Air Filter comes pre-oiled and no oiling is necessary for initial installation. Service the filter as specified in the Cleaning and Oiling the Banks Ram-Air Filter Section of this manual.

INSTALLATION INSTRUCTIONS

1. If a heavy duty hoist is available, raise the vehicle and remove the front wheels for easier access. If the rear wheels remain on the ground, block the rear wheels.

2. Starting from the rear of the vehicle and working forward, remove the exhaust system up to and including the front muffler. Leave exhaust pipe hangers in place on the chassis.

NOTE: Some joints may require the heat from a torch to loosen them for disassembly.

3. Install the small, straight-thru primary muffler to "Y" pipe. Use 3" U-clamp. Install hanger rod on "Y" pipe into factory hanger.

4. Install 28" intermediate pipe in outlet of primary muffler. Install 3" U-clamp to secure pipe in muffler. Install 3" hanger clamp on intermediate pipe to support muffler. See Figure 1.

5. The Ford Class "A" Motorhome chassis is supplied in several wheelbase lengths. The standard length is 178" wheelbase. Longer wheelbase coaches will require an additional extension pipe. These are available from Gale Banks Engineering in a 33" and 53" length to fit 208" and 228" wheelbase coaches, respectively. Other wheelbase coaches may be accommodated by cutting one of these two extension pipes.

Extension pipes are required to fit wheelbase lengths as follows:

A. 178" wheelbase

No additional extension pipe required (use 28" extension pipe supplied in all kits).

B. Up to 208" wheelbase

Requires 33" additional extension pipe.

C. Up to 228" wheelbase

Requires 53" additional extension pipe.

D. Up to 258" wheelbase

Requires 33" and 53" extension pipes.

Install the appropriate additional extension pipe(s) if required. Wheelbases other than 208 or 228 inches will require that the extension pipe be shortened. Add additional 3" hanger clamps (available from Gale Banks Engineering) as required to support extension pipes in factory rubber hangers.

6. Install the secondary muffler on the intermediate pipe or extension pipe. Support rear of muffler with muffler hanger U-clamp provided. **See Figure 2.** Do not tighten hanger clamp at this time. Install, but do not tighten 3" U-clamp at muffler inlet connection.

7. Install tailpipe over rear axle and into muffler outlet connection. Insert tailpipe hanger pin into factory rubber hanger. Rotate secondary (rear) muffler as required to best align muffler with tailpipe and intermediate pipes. Once alignment is determined, tighten clamps at muffler inlet and outlet connections. Hanger clamps on intermediate piping may be loosened and readjusted if necessary. **See Figure 2.**

8. Install intermediate pipe heat shield on intermediate pipe between primary and secondary mufflers. Heat shields install with the shield above the pipe, to protect the coach floor. Because the location of factory pipe hangers will vary, the installer must provide a notch in the heat shield to clear the hanger rod on the U-clamp hanger. **See Figure 3.** Make two saw cuts through the folded lip of the heat shield, one inch into the flat section beyond the fold line. Locate the cuts either side of the hanger rod location. Fold the metal between the cuts back against the flat portion of the shield to provide a clearance notch for the hanger rod. Clamp the heat shield to the intermediate pipe with two 3" U-clamps as shown in **Figure 3.**

9. If an extension pipe has been installed between the intermediate pipe and the secondary muffler, an additional heat shield will have been provided with the optional extension pipe. Overlap this heat shield with the heat shield on the intermediate pipe as shown in **Figure 3.** Mount the shield so the forward end covers the slip joint where the extension pipes join. If the extension pipe had to be shortened for a shorter wheelbase, overlap the heat shield so that it will cover the slip joints at each end of the extension pipe. The long heat shield has clamp holes every few inches to allow the shield to be positioned over as much pipe length as possible when installed. **See Figure 3.** Cut notches as required to clear hanger rods.

10. Install the chrome tailpipe tip by sliding it over the end of the tailpipe. If the tailpipe must be shortened to position the tip near the coach body, cut the tailpipe to place it 1 to 2 inches within the outside end of the tailpipe tip. This will minimize any heat discoloration of the chrome plating on the tailpipe tip. The chrome tip is provided with a single 3/8" U-clamp for mounting.

11. CAUTION! If tailpipe passes below or within 3 to 4 inches of storage compartments, heat shielding will be required to eliminate fire danger or melting of items in the compartments, including carpet. An optional clamp-on heat shield is available from Gale Banks Engineering to provide protection between the tailpipe and compartments above. The heat shield is supplied with two 3/8" U-clamps, use it and the chrome tip U-clamp for mounting the heat shield. **See Figure 2.**

BANKS RAM-AIR SYSTEM

The Banks Stinger cold air induction components are designed to extend the factory air intake path so that cooler outside air can be picked up from directly behind the vehicle's grille. These components include a molded Banks Super-Scoop™, 4" diameter flexible tubing, Ram-Air Filter Cover and installation hardware. **Figure 4.** shows a typical hook-up of the air intake components as they tie to the factory system. The Super-Scoop also serves as a water separator to drain out any rain water that may enter through the grille.

The Banks Stinger cold air induction package is intended to fit a number of motorhome body configurations. Because each coach builder has a different layout of behind-the-grille components, there can be no one set installation procedure for the Banks Ram-Air package. The following instructions are intended as a guideline for installing the Ram-Air system. Also, some coach builders may have installed difficult to relocate components (such as air conditioning freon piping or heater hoses) in the areas where the Banks Ram-Air is normally mounted. In these cases, the installer will have to find an alternate location for the Ram-Air components, or omit these pieces that are impossible to mount.

12. Remove the air cleaner housing cover. Replace the factory paper element and filter cover with the Banks Ram-Air filter element and cover. Use new 6mm x 40mm bolts, don't overtighten.

13. Determine a location for the Banks Super-Scoop. It should be placed as low as possible directly behind the grille, with the air inlet opening pointing straight ahead. If the grille is at an angle, the Super-Scoop should be trimmed at an angle, whenever possible, to place the air inlet opening against the back side of the grille with the centerline of the inlet opening horizontal. **See Figure 4.** Use heavy snips or a hacksaw to trim the air inlet opening of the Super-Scoop. The height between the Super-Scoop and the air inlet hood should be as great as possible to prevent any rain water not eliminated by the Scoop's water drain hole from climbing up into the air filter. The curved outlet section of the Super-Scoop may be trimmed back if less bend is required to make a more streamlined hose routing. **See Figure 4.**

14. Once a location has been determined for the Super-Scoop, mount it using one of the methods outlined below.

The Banks Super-Scoop may be mounted by several means. If the grille consists of horizontal bars or a perforated metal screen heavy enough to support the inductor, it may be secured using four 14" nylon cable ties, provided, slipped through the ears on the Scoop and through the grille. **See Figure 5.**

An alternate method is to mount the inductor using the four perforated metal straps provided. These can be bent as required and attached to the Scoop's ears with the 1/4" 20 x 1 1/4" hex bolts, 1/4"-20 nylock nuts and 3/4" O.D. x 5/8" I.D. flat washers provided. The opposite end of the straps may be attached to any convenient mounting points such as the gravel pan, grille brackets, etc. as required, with four No. 10 x 3/4" sheet metal screws provided. A combination of cable ties and scraps may also be used.

Connect the fresh air inlet on the air filter housing to the Super-Scoop using the 4" diameter flex hose provided. Cut the hose to the desired length using a knife and diagonal cutting pliers. Secure with No. 64 hose clamps.

15. Check over the entire installation for loose clamps or bolts, hoses and wiring too close to hot or moving parts, sharp edges, etc., and correct as necessary.

16. Start engine and listen for any exhaust leaks. Tighten bolts or clamps to correct leaks as required. Allow engine to warm up and test drive vehicle.

NOTE: Exhaust tubing will smoke for the first 15 to 20 minutes of operation. This is normal, as grease used in the bending process will burn off the inside of the pipes.

17. Three Banks PowerPack plaques have been included in your kit. These may be affixed to your vehicle by peeling off the backing and pressing firmly in the desired location. A piece of masking tape applied to the vehicle with reference measurements to other emblems or body trim may be used to level and locate your plaques. **Figure 6** shows suggested locations for plaques.

18. For California vehicles, apply the CARB sticker, supplied, to an under-hood location near other tune-up information.

Figure 1

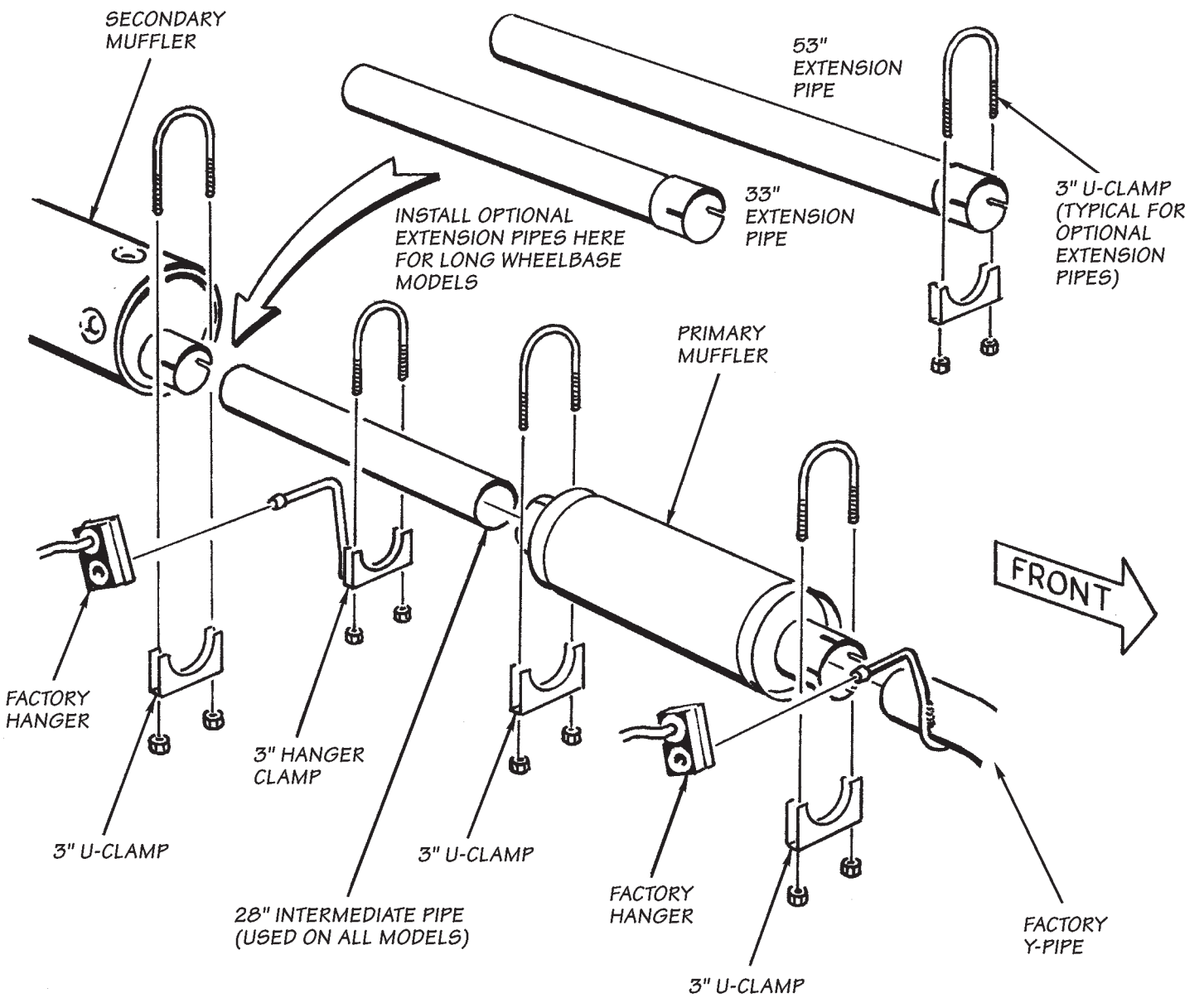

Figure 2

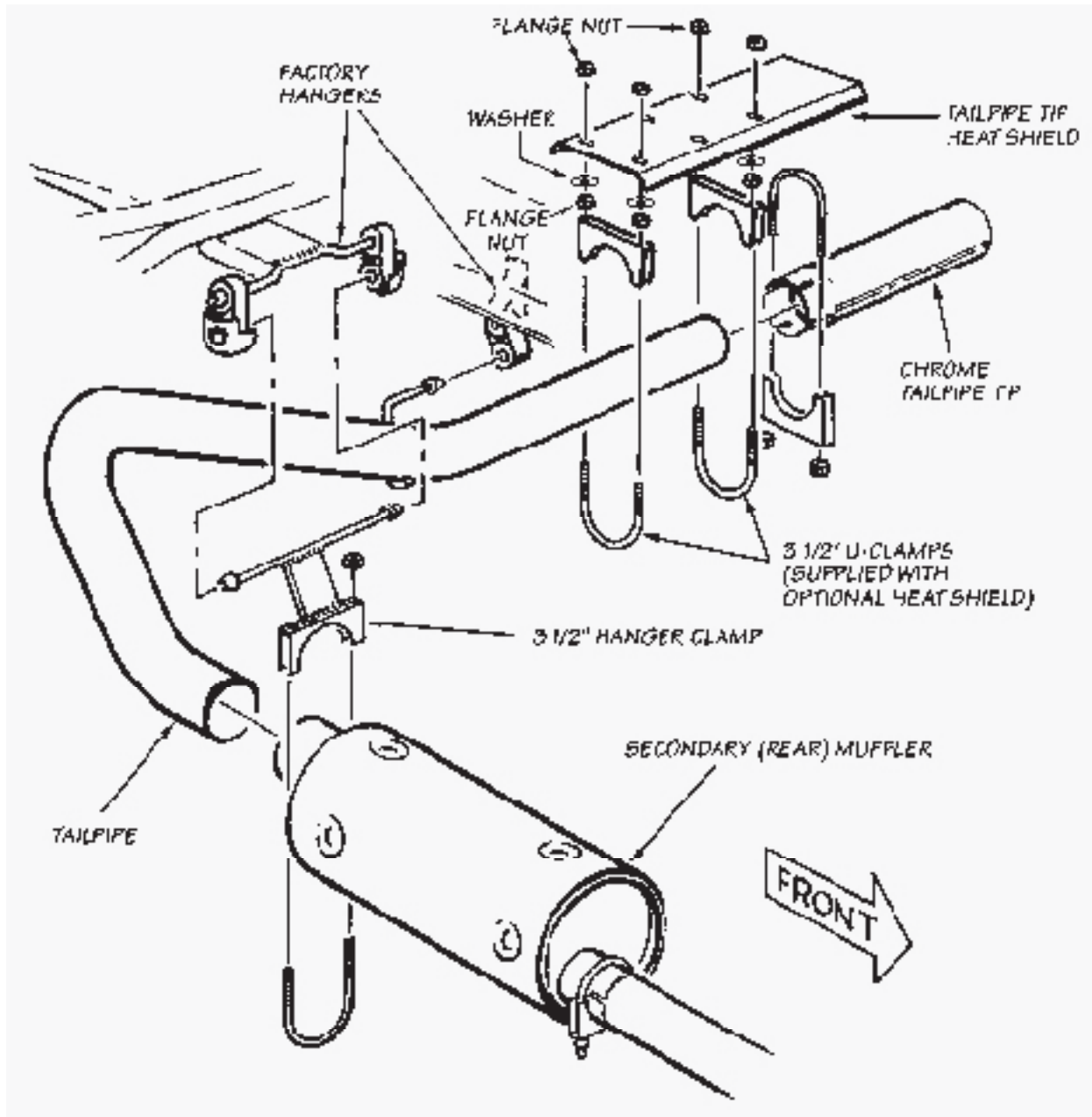

Figure 3

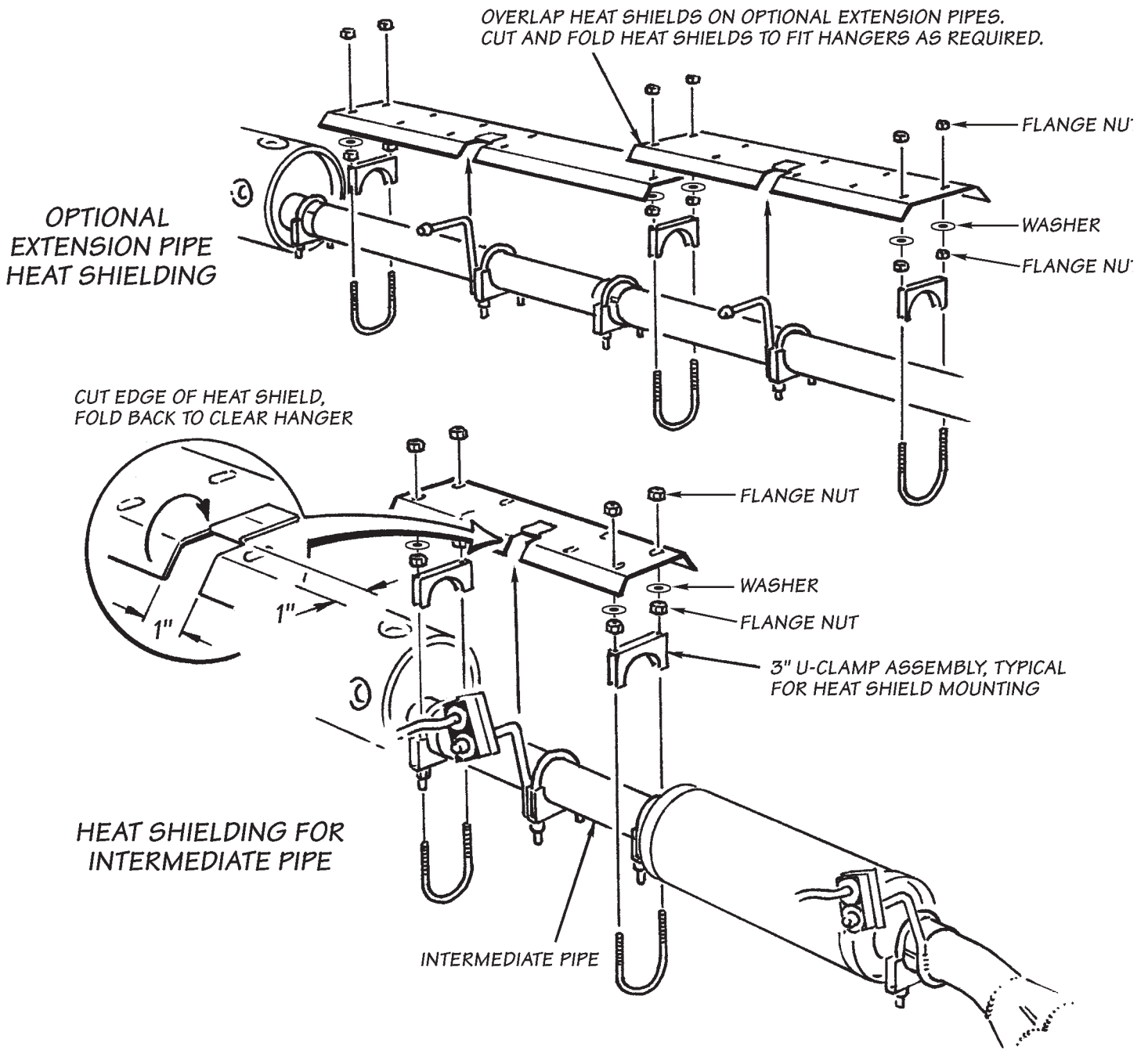

Figure 4

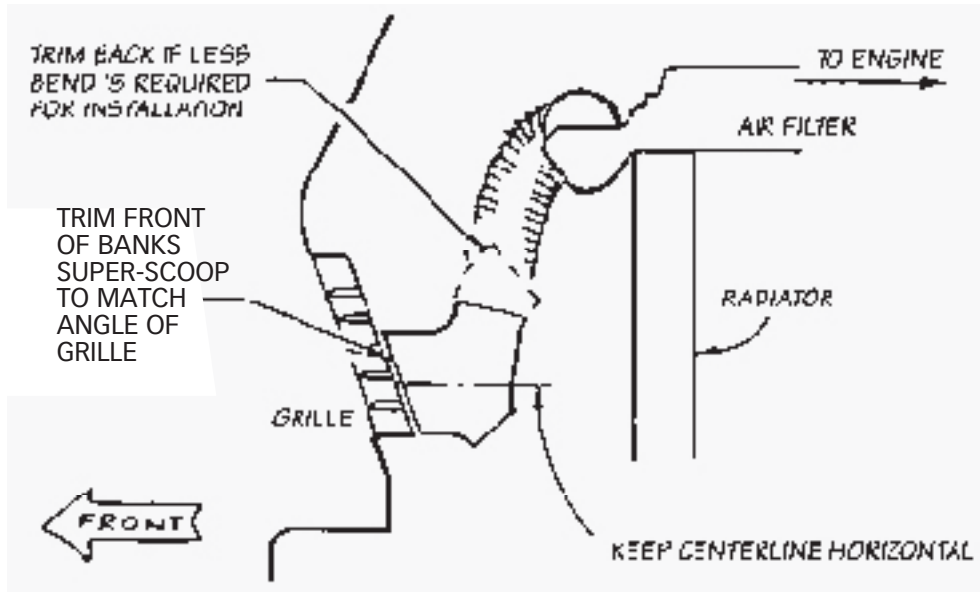
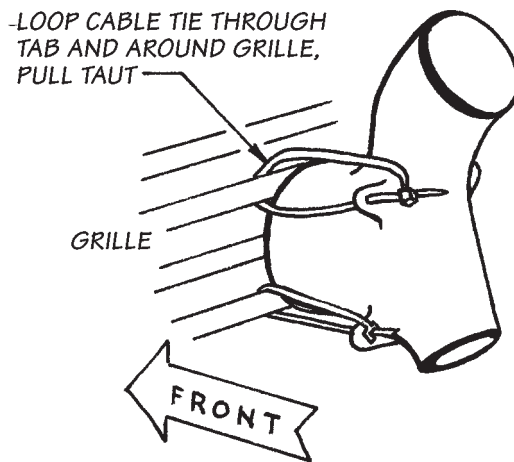

Figure 5

CABLE TIE MOUNTING



STRAP MOUNTING

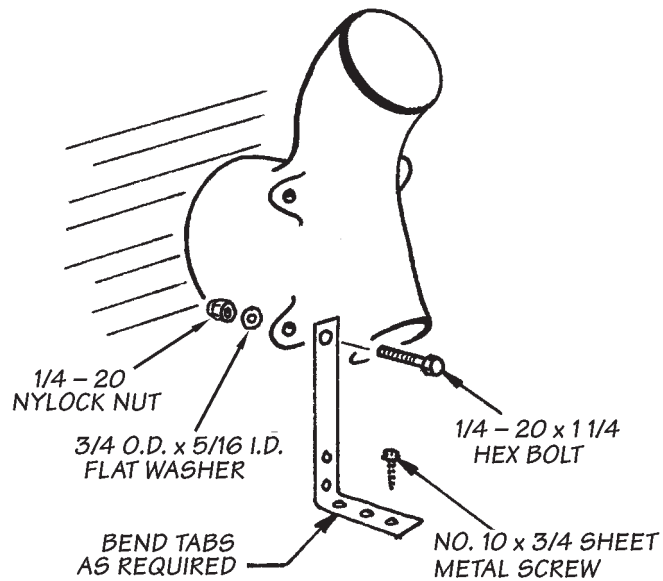
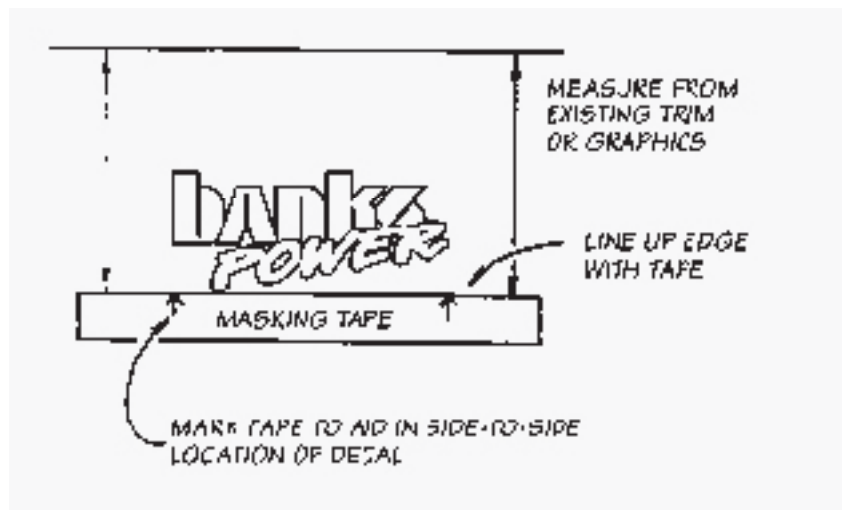
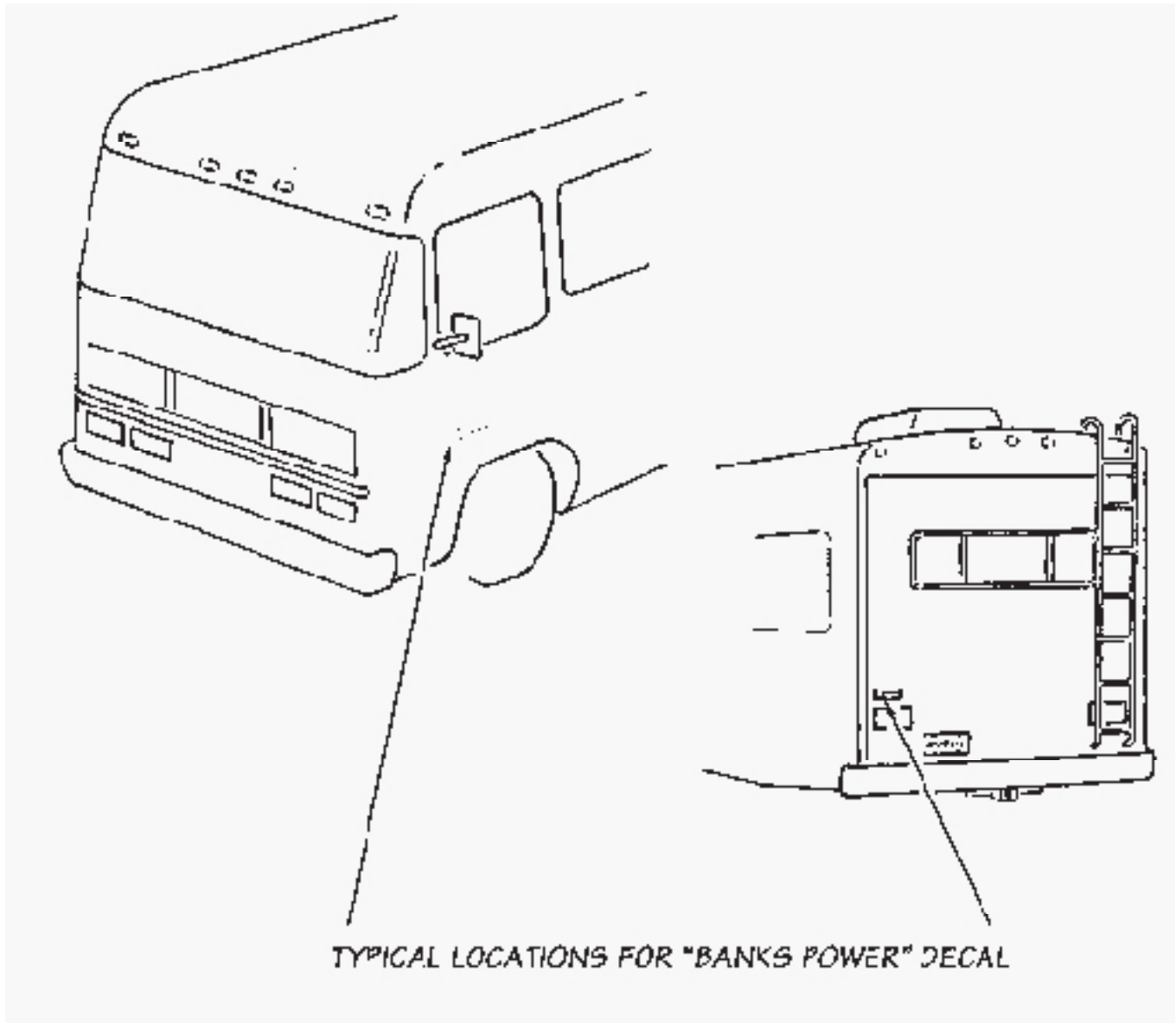

Figure 6



CLEANING AND OILING THE BANKS RAM-AIR FILTER

Notification

The Banks Ram-Air Filter comes pre-oiled and no oiling is necessary for initial installation. Use Banks Ram-Air Filter cleaning system (Part# 90094), available from Gale Banks Engineering to service the Air Filter. Follow the instructions included with the cleaning system to clean and re-oil your Banks Ram-Air Filter.

1. PRE-CLEANING

Tap the element to dislodge any large embedded dirt, then gently brush with a soft bristle brush. NOTE: If complete cleaning is not practical at this time, reoil the element and reinstall in your vehicle.

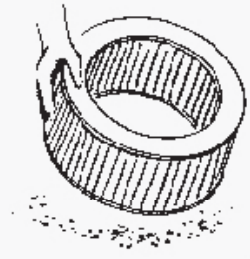

2. SPRAY-ON CLEANING

Spray Banks air-filter cleaner liberally onto the entire element and let soak for 10 minutes.

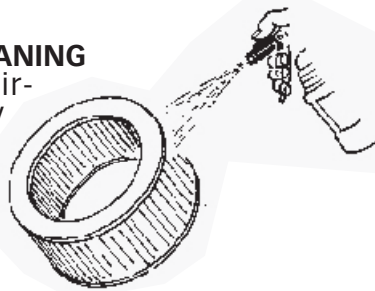

PAN CLEANING

Large air-filter elements can be rolled or soaked in a shallow pan of Banks air-filter cleaner. Remove immediately and let soak for approximately 10 minutes.

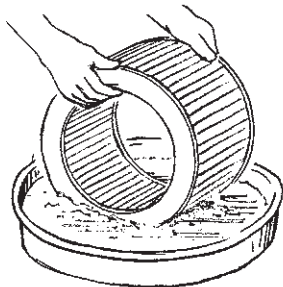

3. CLEANING HINTS

Use only Banks air-filter cleaner. NO gasoline cleaning, NO steam cleaning, NO caustic cleaning solutions, NO strong detergents, NO high-pressure car wash, NO parts cleaning solvents. Any of these NOS can cause harm to the cotton filter media plus SHRINK and HARDEN the rubber end caps.

4. RINSE OFF

Rinse off the element with low-pressure water. Tap water is okay. Always flush from the clean side to dirty side. This removes the dirt and does not drive it into the filter.

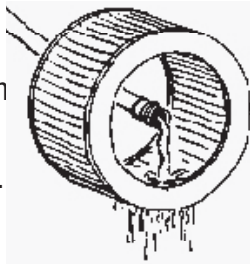

5. DRYING HINTS

Always dry naturally. After rinsing, shake off all excess water and let the element dry naturally.

DO NOT USE COMPRESSED AIR – DO NOT USE OPEN FLAME – DO NOT USE HEAT DRYERS!
EXCESS HEAT WILL SHRINK THE COTTON FILTER MEDIA.
COMPRESSED AIR WILL BLOW HOLES IN THE ELEMENT.

6. AEROSOL OILING

After cleaning air filter always reoil before using. Spray Banks Ram-Air filter oil down into each pleat with one pass per pleat. Wait 10 minutes and re-oil any white spots still showing.

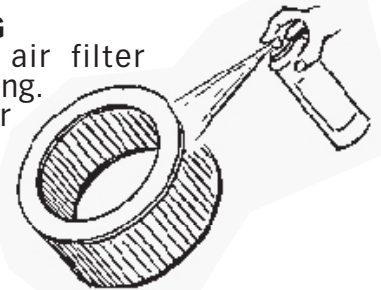

7. OILING HINTS

Never use a Banks Ram-Air filter without oil (the filter will not stop the dirt without the oil). Use only Banks Ram-Air filter oil. Banks air-filter oil is a compound of mineral and animal oil blended with special polymers to form a very efficient tack barrier. Red dye is added to show just where you have applied the oil. Eventually the red color will fade but the oil will remain and filter the air. NEVER USE Automatic Transmission Fluid. NEVER USE Motor Oil. NEVER USE Diesel Fuel. NEVER USE WD40, LPS, or other light-weight oils.

8. REINSTALL

Reinstall your Banks Ram-Air filter element with proper care. Make sure the element seats properly in the filter case. Install the cover making sure it's in the right position. Tighten all the nuts, bolts, screws or clips to factory specifications.

9. DO NOT DISCARD

Affix the "Do Not Discard" sticker to the filter case (included with every Banks replacement element). Make sure you put the sticker in a highly visible place to alert your mechanic not to discard.

10. PERFORMANCE HINTS

Service every 50-100,000 miles on street-driven applications. Service more often in offroad or heavy-dust conditions. If an air-filter restriction gauge is installed, then change the element when the air-filter restriction reaches 18"/H₂O.

CAUTION! Extremely fine dust from agriculture or offroad use will pull the oil from the element. Frequent reoiling of the element's clean side might be required. Completely service when practicable. For extra protection use an air-filter sealing grease on rubber ends of the element. Service only with Banks air-filter cleaner and Banks air-filter oil.

BILL OF MATERIALS

Stinger System, Ford 460 EFI Motorhomes Non-Catalytic Converter

COMPONENT	49224
MUFFLER, 3 x 3½" with Heatshield, Stainless Steel	✓
MUFFLER, 3 x 3", Stainless Steel	✓
PIPE, 3 x 28", Stainless Steel	✓
PIPE, Chrome Tailpipe Tip	✓
PIPE, Heatshield, Intermediate Pipe	✓
PIPE, Tailpipe Assembly, 3½", Aluminized Steel	✓
SUPER-SCOOP™, Banks Ram-Air	✓
FILTER ELEMENT, Banks Ram-Air	✓
COVER, Filter, Banks Ram-Air	✓
SERVICE KIT, Air Filter	✓
CLAMP, Exhaust, 3" HD	✓
2 CLAMP, Exhaust, 3½" HD	✓
CLAMP, Hanger, Intermediate Pipe, 3"	✓
CLAMP, Hanger, Muffler, 3½"	✓
2 CLAMP, Hose, #64	✓
3 HOSE, Air Duct 4" Bulk	✓
4 STRAP, Mounting	✓
4 TIE, Cable, 15" Black	✓
4 BOLT, ¼" 20 x 1¼" Hex	✓
4 BOLT, Ram-Air Filter Cover	✓
4 SCREW, Sheet Metal, #10 x ¾", Hex wsr hd slt	✓
4 NUT, ¼" 20 Nylock	✓
4 WASHER, ¼" USS	✓
OWNERS MANUAL	✓
2 DECAL, Banks Power, Large	✓
2 DECAL, Banks Power, Small	✓
DECAL, Carb E.O. -D-161-38	✓
DECAL, Carb "Rep. Part"	✓
CARD, Product Registration	✓
WARRANTY STATEMENT	✓

Gale Banks Engineering
546 duggan avenue • azusa, ca 91702
(626) 969-9600 • fax (626) 334-1743

Product Information & Sales: (800) 438-7693
www.bankspower.com