

**banks**

with Installation Instructions  
**Owner's Manual**

# **Banks Split-Dual Monster<sup>®</sup> Exhaust System**

**2007-2008 Toyota Tundra 5.7L**

THIS MANUAL IS FOR USE WITH MONSTER EXHAUST SYSTEMS 48133-48134

Gale Banks Engineering  
546 Duggan Avenue • Azusa, CA 91702  
(626) 969-9600 • Fax (626) 334-1743

Product Information & Sales: (800) 438-7693

**bankspower.com**

# General Installation Practices

**1.** Before starting work, familiarize yourself with the installation procedure by reading **all** of the instructions.

**2.** The exploded view (**Figure 1**) provides only general guidance. Refer to each step and section diagram in this manual for proper instruction.

**3.** Throughout this manual, the left side of the vehicle refers to the driver's side, and the right side to the passenger's side.

**4.** Disconnect the negative (ground) cable from the battery (or batteries, if there are two) before beginning work.

**5.** Route and tie wires and hoses a minimum of 6" away from exhaust heat, moving parts and sharp edges. Clearance of 8" or more is recommended where possible.

**6.** When raising the vehicle, support it on properly weight-rated safety stands, ramps or a commercial hoist. Follow the manufacturer's safety precautions. Take care to balance the vehicle to prevent it from slipping or falling. When using ramps, be sure the front wheels are centered squarely on the topsides; put the transmission in park; set the hand brake; and place blocks behind the rear wheels.

**Caution! Do not use floor jacks to support the vehicle while working under it. Do not raise the vehicle onto concrete blocks, masonry or any other item not intended specifically for this use.**

**7.** During installation, keep the work area clean. Do not allow anything to be dropped into intake, exhaust, or lubrication system components while performing the installation, as foreign objects will cause immediate engine damage upon start-up.

## **Tools Required:**

- 1/2" and 3/8" drive ratchets with standard and metric sockets and 1/2" and 3/8" drive extension
- Standard and metric combination or open-end wrenches
- Standard screwdriver
- Clean shop towels or rags
- Pry-bar
- Hacksaw or similar Electric cutting tool

## **Highly recommended tools and supplies:**

- Foot-pound torque wrench
- Penetrating oil or light lubricant spray
- Reciprocating saw

**Figure 1, General Assembly**

Item	Description	P/N	QTY
1	Ring Seal	93167	2
2	Y-pipe	53252	1
3	Intermediate Pipe	53253	1
4	Sliding Hanger Clamp, 3"	53256	1
5**	Clamp	52465	4
6	Monster 3" Muffler	54005	1
7	Hanger Clamp, 3"	53257	1
8	Rear Y-pipe	53259	1
9	Left Tail Pipe	53260	1
10	Right Tail Pipe	53261	1
11	Band Clamp	52466	2
12	Tailpipe Tip	53264	2
13*	Hanger Clamp, Right Y-pipe, 2.5"	53255	1
14*	Hanger Clamp, Left Y-pipe, 2.5"	53254	1
15	Left Hanger Bracket	53262	1
16	Right Hanger Bracket	53263	1
17	Rubber Insulator	53732	2
18	Banks Urocal	96009	2

\* Use Only on Reg. Cab/ Standard Bed

\*\* Reg. Cab/ Standard Bed Use 3 ea.

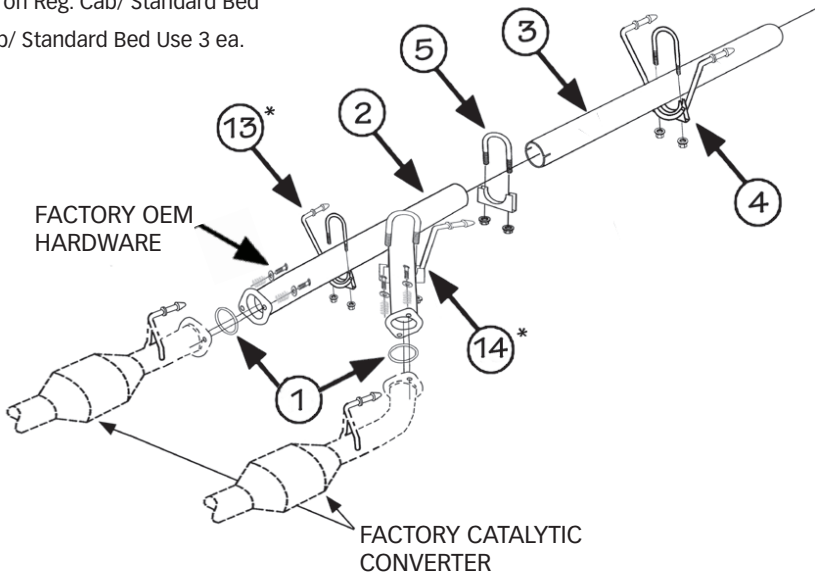

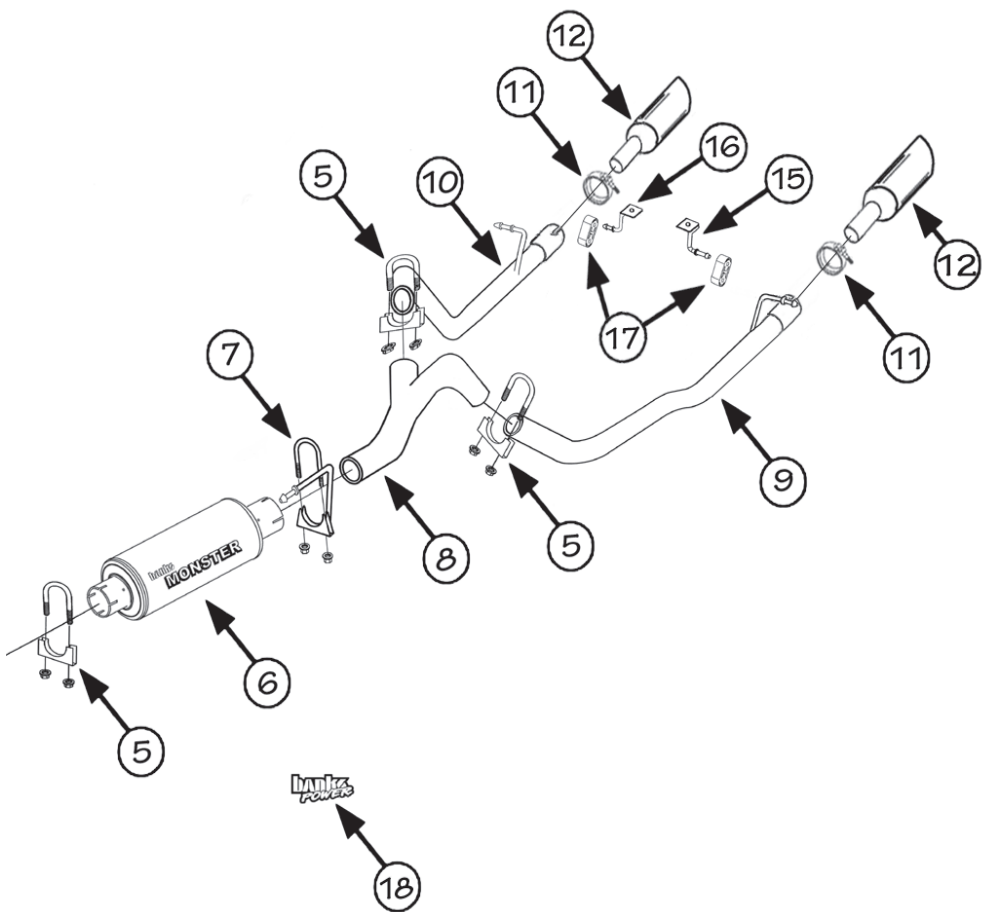

Note: Banks Intermediate pipe ③ and Sliding hanger clamp ④ not applicable to Regular Cab / Standard Bed.

# Monster Exhaust System Installation

**1.** Disconnect the negative (ground) cable from the battery (if there is more than one battery, disconnect both negative cables). Secure the cable so it cannot accidentally come in contact with the post.

**2.** Raise the vehicle and support it securely with properly weight-rated safety stands, ramps or a commercial hoist. Take care to balance the vehicle to prevent it from slipping or falling. When using ramps, be sure the wheels are centered squarely on the topsides. Place the transmission in park (automatic), set the parking brake and securely block the wheels that are on the ground.

**CAUTION: DO NOT WORK UNDER ANY VEHICLE SUPPORTED ONLY BY A JACK. SEVERE INJURY MAY RESULT.**

**3.** From under the vehicle remove the factory exhaust bolts located on both flanged Y-Pipes. Keep the removed bolts. They will be reused in a later step.

*NOTE: Remove the factory gaskets.*

*NOTE: The exhaust system will be hanging by the hanger clamps.*

**4.** Liberally apply an aerosol lubricant on all the hanger pins. Remove the exhaust system from the vehicle by removing each hanger pin from the rubber insulator.

*NOTE: Remove pins from front of vehicle to rear.*

**5.** Drop the exhaust system to the floor and move out of the way. You will not be reusing any components from the exhaust system.

**6.** Locate the supplied Y-pipe and Y-pipe ring gaskets from your kit. Install the Y-Pipe and ring gaskets onto

the flanged fitting on the stock catalyst converters. Loosely tighten the flange bolts.

## Regular Cab / Standard Bed Only

**7.** If applicable, locate the supplied 2.5" hanger clamps and install onto the Y-pipe. See **Figure 1**. Do this for both pipes on the Y-pipe. Install the pin on the hanger. Loosely tighten the hanger clamps.

*NOTE: When installing hanger pins into rubber insulators make sure that the pin is properly pushed in place. See **Figure 3**.*

## All others

**8.** If applicable, locate the supplied intermediate pipe and cut the intermediate pipe based on the following configurations. See **Table 1**. Cut the NON-swedged end of the intermediate pipe. See **Figure 2**.

*NOTE: Banks Intermediate pipe not applicable to Regular Cab / Standard Bed.*

**9.** Locate and install the intermediate pipe swedged end onto the Banks Y-pipe. Install a 3" saddle clamp onto the swedged end and loosely tighten. Slide on the sliding hanger clamp onto the intermediate pipe such that the hanger pins face the rear of the vehicle. Install the clamp hanger pins into the corresponding vehicle rubber insulators and loosely tighten the clamp. See **Figure 3**.

**10.** Install the 3" exhaust clamp onto the inlet of the Banks Monster Muffler (*Note: the inlet labeling of the muffler*). Orient the "Monster" logo such that it is parallel with the frame rail. Install the Banks Muffler inlet onto the intermediate pipe and lightly tighten the 3" clamp.

**Figure 2**

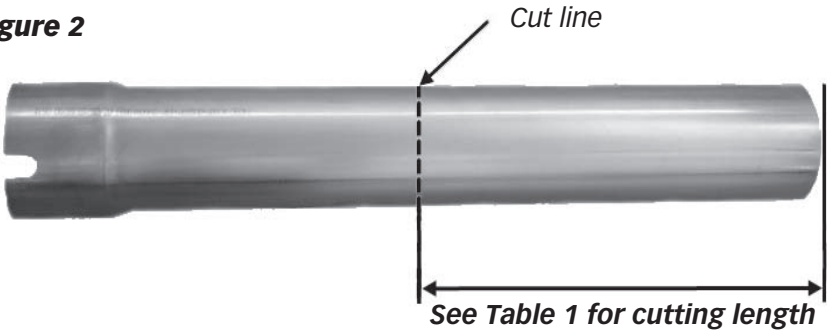

**Table 1**

<b>2007-2008 Toyota Tundra 5.7L</b>		
	Wheel Base	Cut this length from the Intermediate Pipe. See <b>Figure 2</b> .
Reg Cab/ Standard Bed	126.8"	No Interm Pipe included
Reg Cab/ Long Bed	145.7"	19"
Double Cab/ Standard Bed	145.7"	19"
Double Cab/ Long Bed	164.6"	No Cut (Full Length)
Crew Max/ Short Bed	145.7"	19"

**Figure 3**

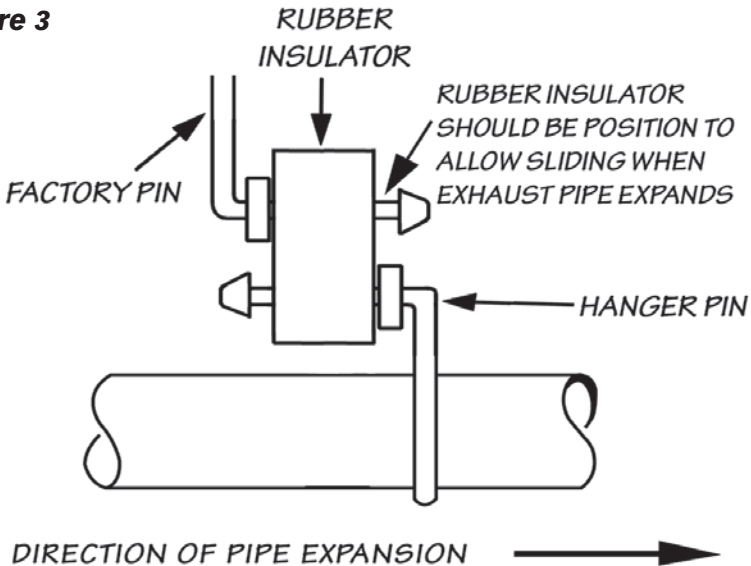

*NOTE: All clamps should be positioned at the beginning of the slots (on the 1/2 circle punch) and evenly tightened. See **Figure 4**.*

**11.** Install the 3" hanger clamp onto the Banks Muffler outlet such that the hanger pin is facing forward. Install the clamp hanger pin into the corresponding vehicle rubber insulator. See **Figure 3**.

**12.** Install the Banks rear Y-pipe into the muffler outlet such that the outlets are pointing up. Install clamps onto each Y-pipe outlet.

**13.** Install the Banks hanger brackets onto the rear of the frame rail. Be sure the hanger pin is align parallel to the frame rail and torque the hardware to 48ft.-lb. See **Figure 5**.

**14.** Install the supplied rubber insulators onto the Banks hanger brackets.

**15.** Install the driver-side tailpipe onto the left Y-pipe outlet. install the driver-side tailpipe hanger into the vehicle rubber insulator. See **Figure 6**.

**16.** Install the passenger-side tailpipe onto the right Y-pipe outlet. install the passenger-side tailpipe hanger into the vehicle rubber insulator. See **Figure 6**.

**17.** Move the spare-tire to the rear of the vehicle and center between the dual tailpipes. tighten the spare tire with the manufacture tire tool so that it is retained into place (see **Figure 7**).

**18.** Install the 3" Band clamp onto the outlet of the left tailpipe and install the left tailpipe tip onto the left tailpipe. Keep the wrapping on until installation is complete. The tip and the clamp should be rotated so the clamp nut and drain hole are pointing down. Repeat this process for the right side tailpipe tip installation.

**Figure 4**

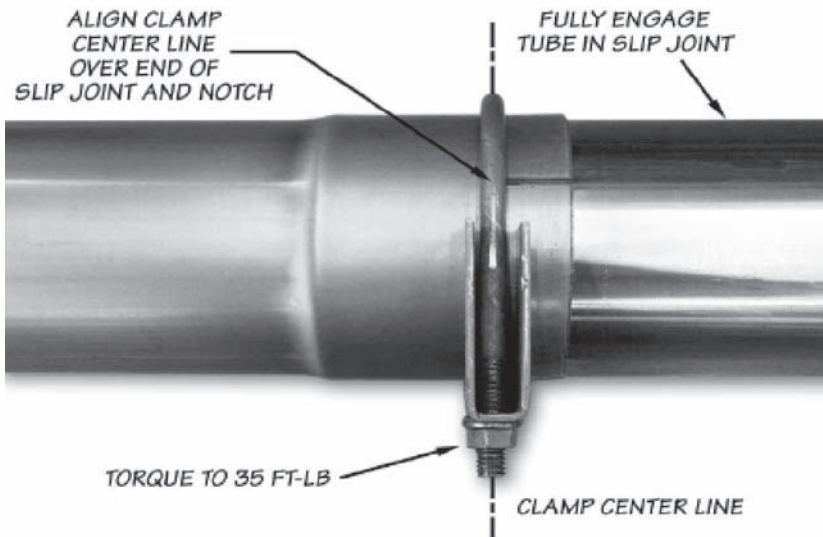

**Figure 5**

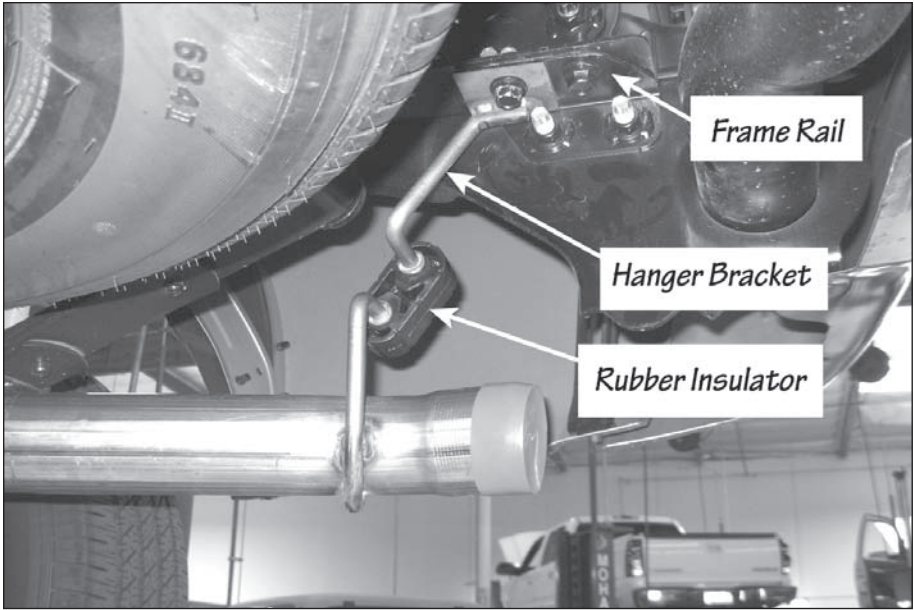

**Figure 6**

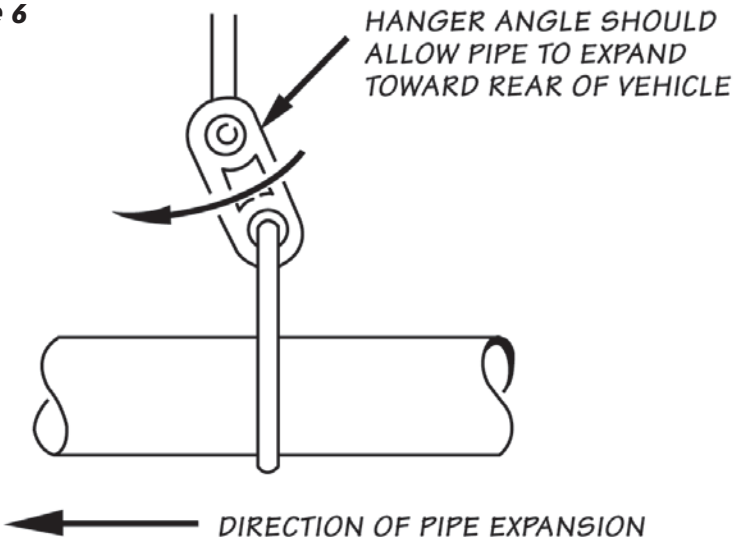

**Figure 7**

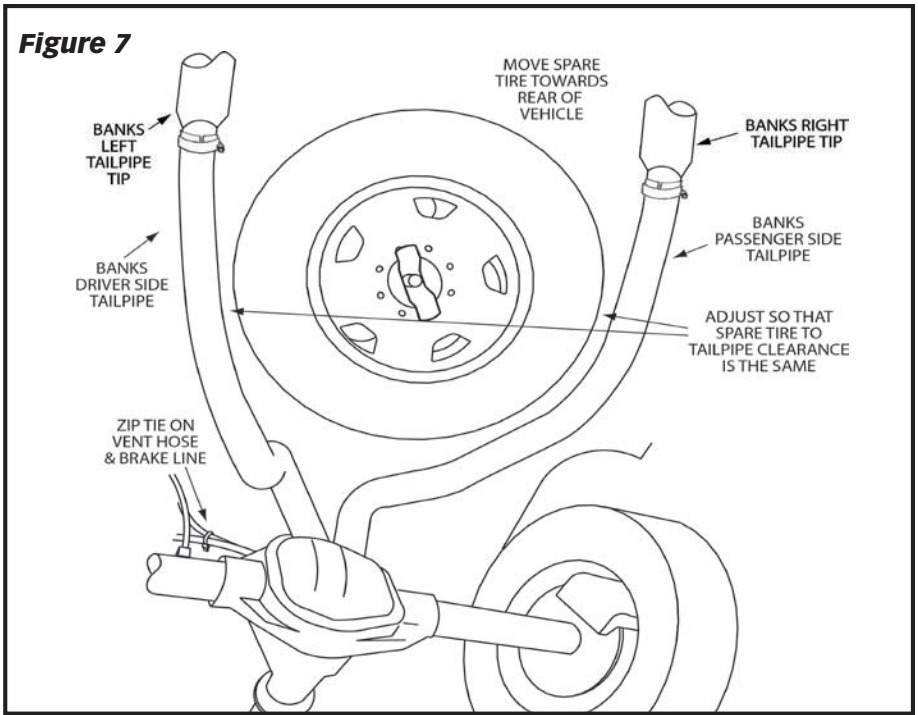

**19.** Be sure that the two (2) tailpipes are completely engaged into the Y-pipe. Adjust your tailpipes so that the tips are symmetrical and 1" below the rear bumper. The hanger pins should be parallel with the frame-mounted pin and the rear rubber hangers are all slightly positioned forward.

*NOTE: Recommended distance between exhaust tip and body is half (1/2") inch to one (1") inch.*

**20.** Beginning with the clamps closest to the catalytic converters, and working your way back, align the saddle clamps to the radius of the corresponding pipe slots. Torque the nuts on each of the exhaust clamps to 35 ft-lb.

**21.** Remove the protective covering from the tailpipe tips.

**Caution: the protective covering may ignite and burn if not removed prior to running the engine.**

**Figure 8**

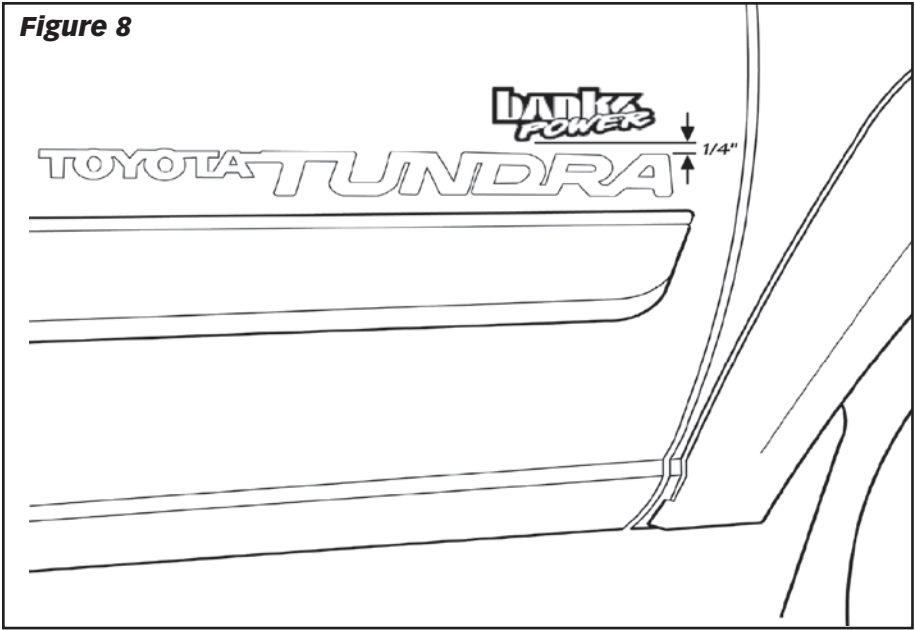

**22.** Your system includes two (2) Banks Power logos designed to complement the Toyota Tundra emblems on the vehicles front doors. Use the provided measurements for a clean factory look (see **Figure 8**).

**23.** Re-connect the negative battery cable. Start the engine and listen for exhaust leaks. Tighten the exhaust clamps as necessary. Whenever possible, tack weld slip connections to prevent disengagement is recommended. The Banks Monster Exhaust installation is now complete.

Gale Banks Engineering  
546 Duggan Avenue • Azusa, CA 91702  
(626) 969-9600 • Fax (626) 334-1743

Product Information & Sales: (800) 438-7693

**bankspower.com**