

with Installation Instructions

Owner's Manual

Banks PowerPack[®] System Including: Banks Stinger[®] System Banks Git-Kit[™]

1997-2005 Ford 6.8L V-10 Class-A Motorhome

THIS MANUAL IS FOR USE WITH SYSTEMS 49140, 49141, 49142, 49143,
49146, 49147, 49160 & 49161, 49164-49167, 49181, 49190

Gale Banks Engineering
546 Duggan Avenue • Azusa, CA 91702
(626) 969-9600 • Fax (626) 334-1743

Product Information & Sales: (800) 438-7693

bankspower.com

General Installation Practices

Dear Customer,

If you have any questions concerning the installation of your Banks Stinger system, please call our Technical Service Hotline at (888) 839-2700 between 7:00 am and 5:00 pm (PT). If you have any questions relating to shipping or billing, please contact our Customer Service Department at (888) 839-5600.

Thank you.

1. For ease of installation of you Banks system, familiarize yourself with the procedure by reading the entire manual before starting work.
2. The exploded views provide only general guidance. Refer to each step and section diagram in this manual for proper instruction.
3. Throughout this manual, the left side of the vehicle refers to the driver's side, and the right side to the passenger's side.
4. Disconnect the ground cables from the battery before beginning work. If the vehicle has more than one battery, be sure that the engine

primary battery is disconnected. This is necessary for safety and to ease the installation of the passenger side TorqueTube® exhaust manifold.

5. Route and tie wires and hoses a minimum of 6 inches away from exhaust heat, moving parts and sharp edges. Clearance of 8 inches or more is recommended where possible.

6. When raising the vehicle, support it on properly weight-rated safety stands, ramps or a commercial hoist. Follow the manufacturer's safety precautions. Take care to balance the vehicle to prevent it from slipping or falling. When using ramps, be sure the front wheels are centered squarely on the topsides; put the transmission in park; set the hand brake; and place blocks behind the rear wheels. If the vehicle is supported by a hoist, the front wheels may be removed for further accessibility. **CAUTION!** Do not use floor jacks to support the vehicle while working under it. Do not raise the vehicle onto concrete blocks, masonry or any other item not intended specifically for this use.

7. During installation, keep the work area clean. If foreign debris is transferred to any Banks component. Clean it thoroughly before installing.

Tools Required

- 1 1/4" wrench
- 5mm 6 point socket
- Chisel or hacksaw
- Saw or torch
- Clean shop towels or rags
- Pry bar or channel lock pliers
- 1/4" and 3/8" drive ratchets with metric sockets and a 1/4" drive extension
- Metric combination or open-end wrenches
- Standard and Phillips head screwdrivers
- Penetrating oil or light lubricant spray
- Standard and phillips head screwdrivers

Table of Contents

General Assembly	4
Section 1	6
Torquetube Manifolds	
Section 2	9
Monster Exhaust	
Section 3	11
Ram Air Intake	
Section 4	14
Ottomind Installation	
Bill of Materials	15-16

General Assembly

Figure 1 See Bill of Materials on page 15

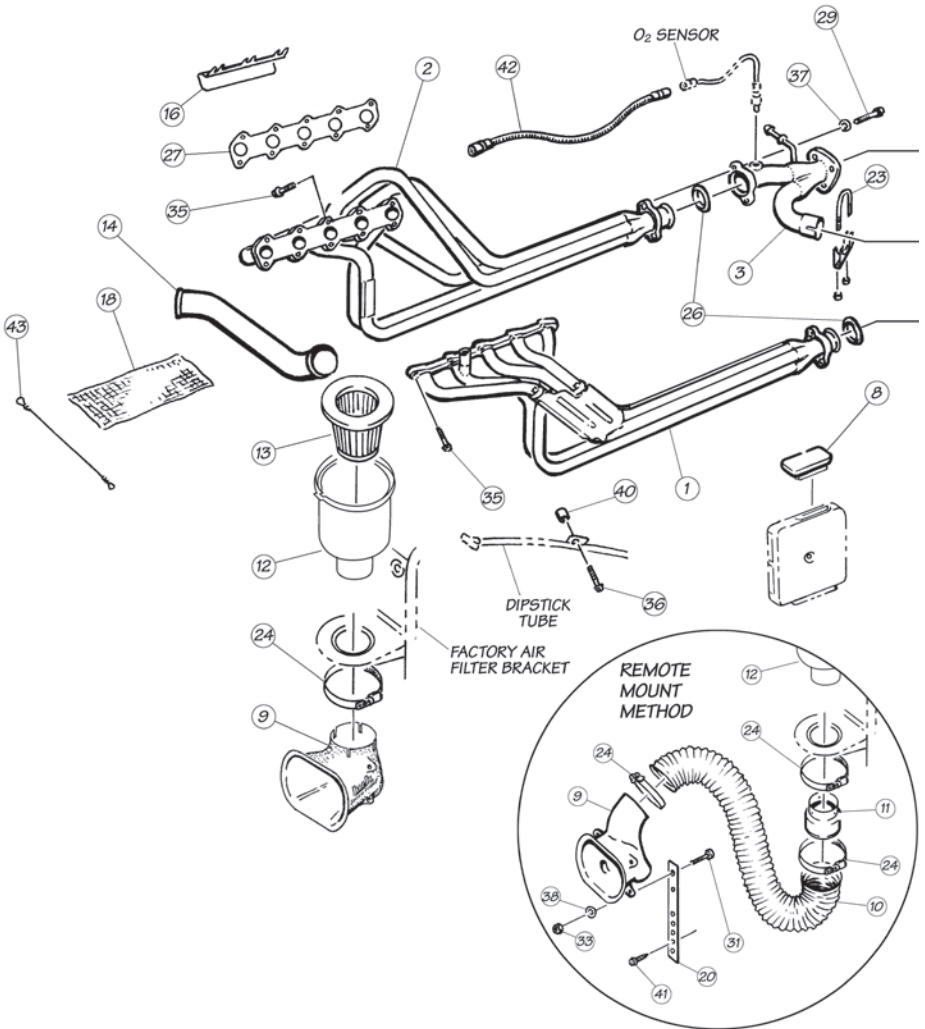

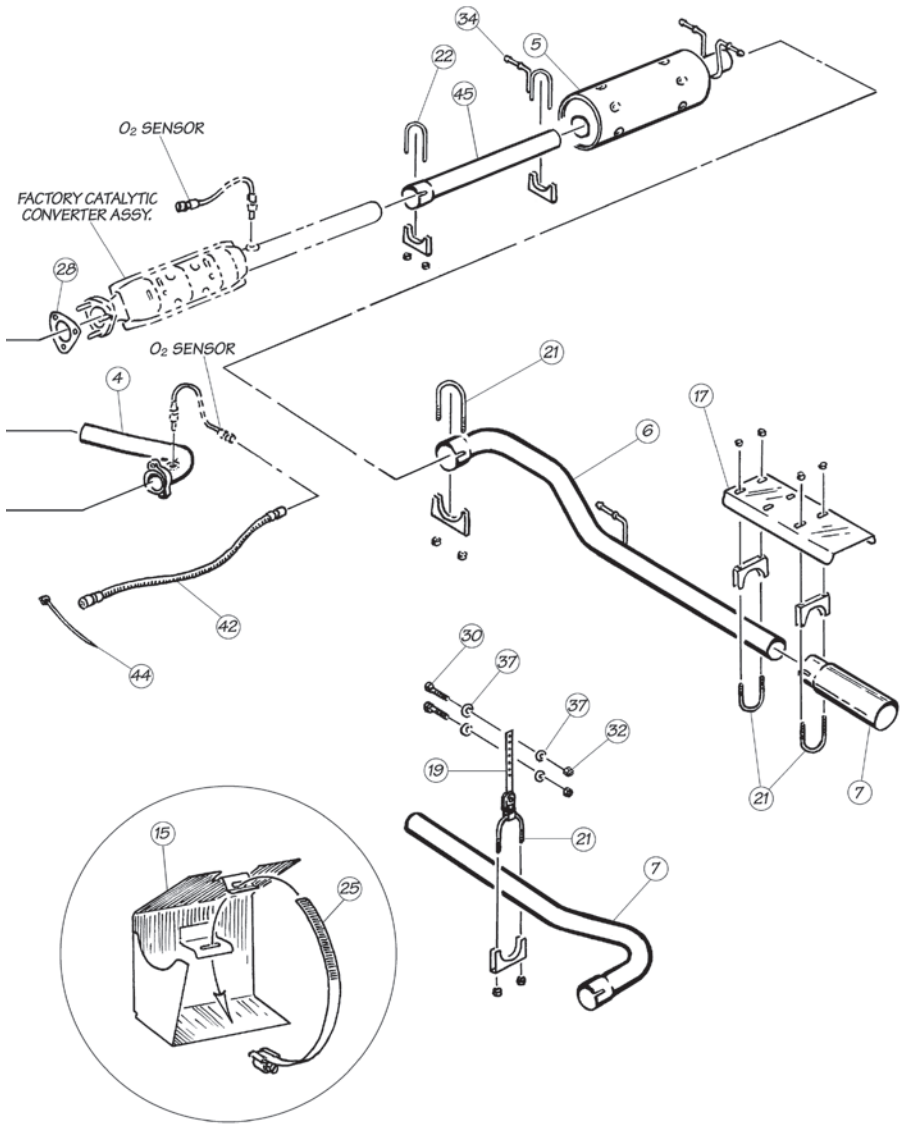

Section 1

TORQUETUBE MANIFOLDS

For Git-Kit & Stinger installation, proceed to step 24.

1. The vehicle may have a bolted in crossmember between the leveling jacks at the front of the vehicle. This will need to be removed prior to removing the factory exhaust system and reinstalled after the Banks PowerPack system is place.

2. Locate the oxygen sensors in each exhaust headpipe, downstream of the factory exhaust manifolds. Unplug the connectors and remove both the oxygen sensors. Mark the sensors for correct reinstallation.

3. Disconnect the three-bolt flange at the front of the catalytic converter from the factory Y-pipe assembly. Disconnect the headpipes from the exhaust manifolds and remove the Y-pipe assembly from the vehicle.

4. On the driver's side of the engine, unscrew the EGR tube from the exhaust manifold with a 1¼" wrench and remove the EGR tube from the manifold.

5. Pull out the dipstick and remove the small bolt that attaches the oil pan dipstick tube to the cylinder head. At the front of the vehicle, behind the front engine cover, remove the 2 screws that retain the dipstick tube to the radiator support. Near the exhaust manifold, pull the dipstick tube up out of the engine block. Check to see if there is an O-ring on the tube. If not, the O-ring may be stuck inside the hole in the engine block. This O-ring should be retrieved if necessary and placed back onto the tube before reinstalling it.

6. To remove the exhaust manifolds, use a wrench or socket to back the nuts away from the manifolds at least one turn, then use a 5mm 6 point socket to remove each stud from

the head. As an alternate method, take the nuts off the studs, and then remove the studs.

7. After the manifolds have been removed from the vehicle, remove any remaining studs from the heads. The studs must be removed from the heads in order to install the Banks TorqueTubes.

8. On EGR models, remove the large EGR adapter fitting from the left side factory manifold and install it onto the left Banks TorqueTube manifold. Reuse the original copper washer between the manifold and adapter. Use anti-seize on the threads to prevent galling. On non-EGR models, install the ¾ npt pipe plug into the EGR fitting on the manifold.

9. On the passenger side of the engine, loosen the three rearmost outside valve cover with bolts. Slide the valve cover heat shield provided under the heads of the bolts and tighten. See figure 2.

10. On some vehicles a wire loom bundle runs along the top of the frame rail adjacent to the driver's side of the engine. In these instances this loom and any other wiring must be relocated away from the exhaust manifold heat area. Pry the wire loom clips from the frame rail to provide enough slack in the wire loom bundle so it may be routed and tied up against the underside of the floor of the coach. The wire loom bundle may be routed up braces adjacent to the upper engine area and along supporting members under the floor with the cable ties provided.

11. Install the starter heat shield onto the starter using the #52 hose clamp provided. Caution: Make sure the heat shield does not come in contact with the positive terminal of the starter once the heat shield is tightened down. See figure 3.

Figure 2

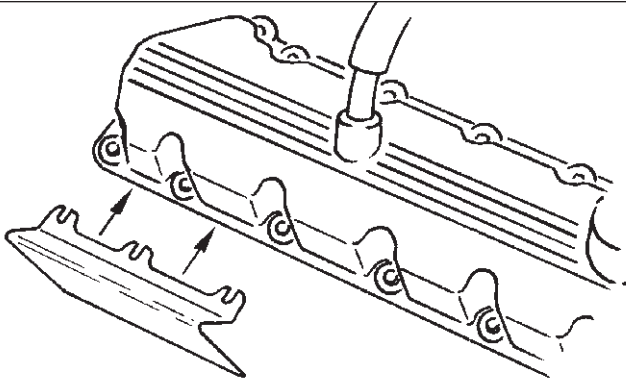

12. On some motorhomes there is a vertical hose fitting on top of the air conditioner compressor. (Skip this step if your motorhome does not have the vertical fitting.) Before installing the right side TorqueTube, bend the hose fitting $\frac{1}{4}$ - $\frac{1}{2}$ inch towards the frame rail using a pry bar. Be careful not to crease or puncture the fitting. This will give clearance for the TorqueTube. Wrap the hose with the supplied heat shield blanket. Secure the blanket to the hose with the supplied wire ties.

13. Inspect the exhaust mounting surfaces of the cylinder heads and clean away any deposits to assure proper sealing of the Banks TorqueTubes. Be careful when doing this as the cylinder heads are made from aluminum, and can be easily damaged. We recommend the use of a Scotchbrite® pad.

14. Place a small amount of anti-seize on the threads of each of the supplied manifold bolts. Use the new gaskets provided when installing TorqueTubes. Lift the Banks TorqueTube manifolds into place and install one or two bolts to hold them in position. Install the remaining bolts into the heads and tighten. See figure 1.

15. On EGR models, attach the EGR tube to the adapter fitting in the Banks TorqueTube manifold. If necessary, loosen the fitting at the top of the EGR

Figure 3

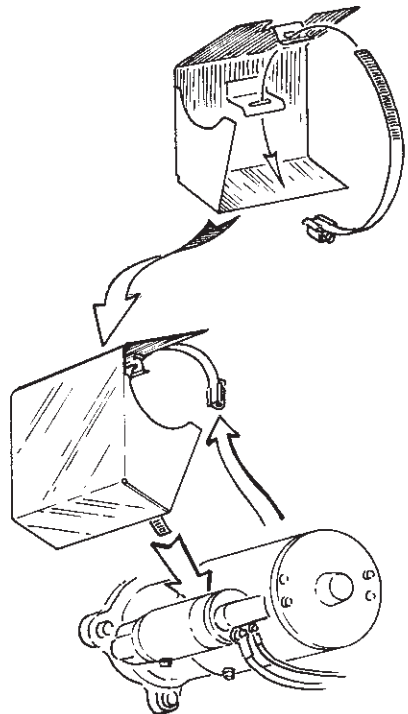

tube to allow the tube to be positioned properly.

16. Make sure the O-ring is on the dipstick tube, and reinstall it into the hole in the engine block. Reattach the dipstick tube bracket to the cylinder head with the new, longer bolt and spacer supplied. Reattach the bracket at the radiator core support with the original hardware and put the dipstick back in.

17. If additional clearance at the front of the right side TorqueTube manifold for the air conditioning hose is needed, very gently bend the line away from the manifold until there is a minimum of $\frac{3}{4}$ " of clearance. Do not use a pry bar or other tool to bend it as this may damage the line. Wrap the air conditioning line with the aluminum heat shielding blanket provided, and tie it with the supplied wire ties.

18. If it was removed, reinstall the crossmember at the front of the vehicle.

19. Place the new catalytic converter flange gasket onto the studs on the catalytic converter flange. Install the Y-pipe onto the catalytic converter using the original hardware, and the pin hanger into the rubber hanger on the frame of the vehicle. Place a conical seal into the flare at the forward end of the Y-pipe, and attach the Y-pipe to the right side TorqueTube manifold using the $\frac{3}{8}$ " x $1\frac{3}{4}$ " bolts and washers provided. Do not tighten the bolts yet.

20. Slip a $2\frac{1}{2}$ " muffler clamp over the free end of the Y-pipe, and then slide the Y-pipe extension into the slip joint. With the slip joint fully seated, mark the extension pipe with a pen so that as the clamp is tightened, any slippage of the joint can be observed. Place the second conical seal onto the flare on the extension, and attach

the extension pipe to the left side TorqueTube with the $\frac{3}{8}$ " x $1\frac{3}{4}$ " bolts and washers provided. Tighten the $2\frac{1}{2}$ " clamp at the slip joint, observing the mark to be sure the joint stays fully seated as the clamp is tightened. Up to $\frac{1}{4}$ " slip is acceptable. Tighten the bolts at the manifold collectors.

21. Install and tighten the oxygen sensors into the threaded bungs provided on the Y-pipe and extension. Use a small amount of anti seize on the threads of the oxygen sensors. Be careful to not get any anti-seize on the sensor elements themselves.

22. On the connector on the oxygen sensor and on the male connector on the sensor extension lead, remove the two index pins on the connector shell, by cutting or filing. Be careful to not damage the locking mechanism of the connectors. See figure 4.

23. Plug the oxygen sensor extension leads included in the kit into the wiring harness where each sensor was previously connected, then plug the sensor lead into the extension. Secure the leads away from any pipes or moving linkages with the cable ties provided.

-END, SECTION 1-

Figure 4

**REMOVE INDEX PINS
FROM PLUGS**

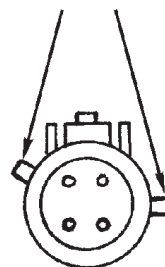

Section 2

MONSTER EXHAUST

24. Disconnect and remove the factory tailpipe and muffler from the rear of the factory intermediate pipe. Start from the rear and work forward, prying the pins from the rubber hangers, removing the tailpipe, then the muffler. If the slip joints will not come apart, use a torch to heat the connections until they separate, or cut the pipes apart with a saw or torch, being careful to not cut the outlet portion of the intermediate pipe. Save all hardware and hangers as some items will be reused in the PowerPack installation. NOTE: Wheelbases over 208" may need to use extension kit P.N. 49097.

25. Slide a 3" exhaust clamp over the forward end of the Banks Dynaflow® muffler assembly and install the assembly onto the end of the catalytic converter outlet pipe. Position the pin hangers on the muffler assembly into the rubber hangers on the frame, and adjust the rotation of the muffler as necessary to position the hanger pins level in the vehicle. Make sure that the hangers are hanging forward. This will allow the hangers to swing as the exhaust system expands while the engine is running. With the muffler level and square to the frame of the vehicle, tighten the clamp on the muffler assembly inlet.

Figure 5

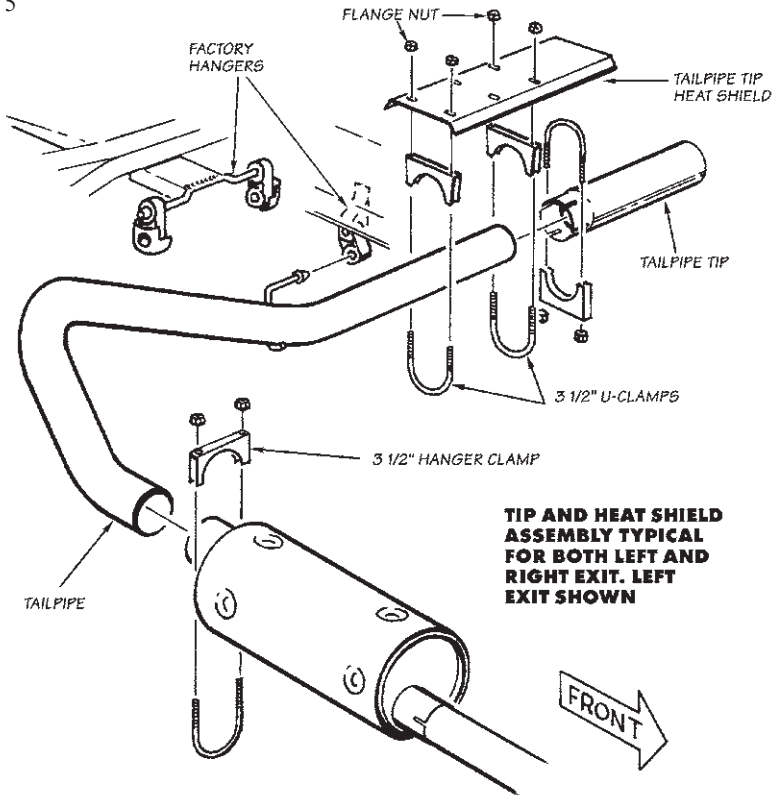

26. Two tailpipe options are available to provide either a right side or left side tailpipe exit. Refer to the installation steps that are appropriate to your installation.

Left exit tailpipe: position a 3¹/₂" clamp over the muffler outlet, and place the Banks Monster tailpipe up over the driveshaft and slide it into the outlet of the muffler. Place the pin hanger on the pipe into the rubber hanger attached to the left side of the frame. Support the pipe level with the vehicle and tighten the clamp.

Right exit tailpipe: place a 3¹/₂" clamp over the muffler outlet, and insert the Banks Monster tailpipe into the end of the muffler. Attach the universal hanger to the tailpipe with a 3¹/₂" clamp, then find a suitable hole in the frame rail directly over the tailpipe. With the tailpipe supported level with the vehicle, bolt the hanger into

the hole with the 5/16" x 1 1/4" bolt, washers and nuts also provided.

27. Mount the floor heat shield and polished tip onto the pipe using the 3¹/₂" clamps provided, as shown in figure 5.

28. Lower the vehicle and reconnect the battery cables. Start the engine and listen for any exhaust leaks. Tighten bolts or clamps to correct any leaks or make adjustment as required. It is recommended that tack welds be placed on all slip connections to prevent slippage.

Note: The vehicle exhaust may smoke upon initial start-up. This is normal, as grease used in the tube-bending process burns out of the pipes.

For Git-Kit installation, procedure is complete.

-END, SECTION 2-

Section 3

RAM AIR INTAKE

Figure 6

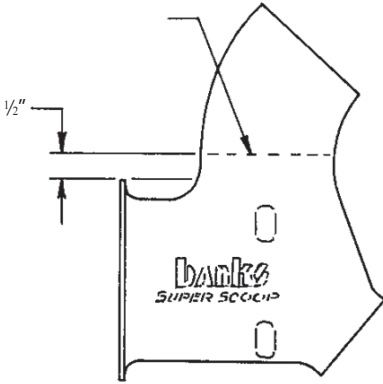

MAKE FOUR 1/2 INCH DEEP SAW CUTS AROUND END OF SUPER-SCOOP OUTLET

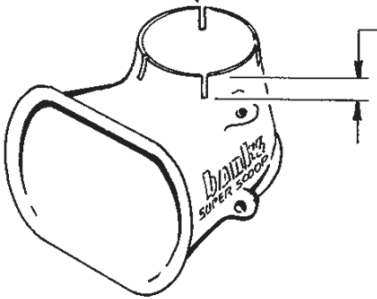

29. Inside the vehicle with the engine cover removed, find the rubber bellows at the inlet of the throttle body. Loosen the clamp attaching the plastic air inlet tube to the bellows, loosen it and pull the plastic air inlet tube out of the rubber bellows. At the front of the vehicle, loosen the clamp that holds the forward end of the air inlet tube to the air filter housing elbow. Remove the tube from the air filter housing, elbow and pull the tube forward, out of the vehicle.

30. To install the Banks Ram-Air inlet tube into the vehicle, place the forward end into the air filter housing elbow, and the rear end into the rubber bellows on the throttle body. Tighten both clamps.

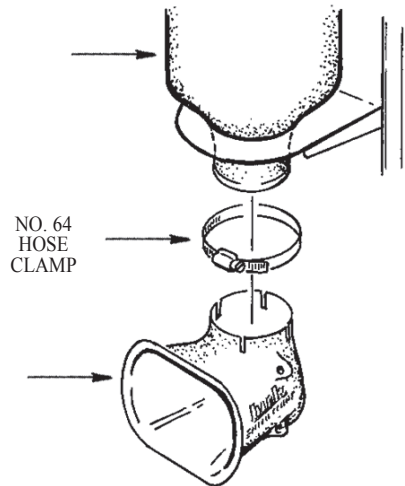

31. Unlatch the clamp that holds the two halves of the air filter housing together and remove the original filter. Remove and discard the plastic cover from around the air inlet of the lower housing. Remove the lower housing from the vehicle by unhooking the rubber strap from the mounting brackets and pulling the housing forward so that the feet disengage from the rubber mounting grommets.

32. Install the Banks Ram-Air filter housing in place of the factory housing. Make sure that the mounting feet fully engage the rubber grommets, and the strap is reattached. Install the Banks Ram-Air filter into the filter housing. Reattach the upper half, making sure the two halves are properly seated together and latch the clamp.

Note: The Banks Ram-Air Super-Scoop may be installed in one of two configurations. One method mounts the scoop directly to the air filter inlet at the bottom of the filter housing. This method is the preferred method but can only be used if there is room below the air filter housing to accommodate the Super Scoop. The other method mounts the scoop to the grille, or directly behind it, and connects the scoop to the air filter housing via a flexible hose.

To mount the scoop directly to the air filter housing, follow the directions in step 33. To mount the scoop to the filter via the hose, skip step 33 and follow the directions in steps 34 thru 38.

33. Cut off the curved portion of the Super Scoop outlet $\frac{1}{2}$ inch above the edge of the inlet lip as shown in figure 6. Next make four saw cuts $\frac{1}{2}$ inch deep, equally spaced around the cut end of the Super Scoop outlet. Deburr the cut edges to remove plastic chips. Slide the modified Super Scoop outlet over the inlet of the air filter housing, aim the scoop inlet toward the vehicle

grille, and secure with a No. 64 hose clamp positioned over the four saw cuts. Proceed to step 39.

34. Install the Banks Ram-Air hose connector onto the bottom of the air filter housing with a #64 hose clamp. This part adapts the $3\frac{1}{2}$ " outlet of the filter housing to the 4" Ram-Air duct.

35. Determine a location for the Ram-Air Super-Scoop®. It should be placed as low as possible, directly behind the grille, with the air inlet opening pointing directly forward in the vehicle.

36. The height difference between the Super-Scoop and the air filter inlet should be as great as possible, to prevent any rain water not eliminated by the water drain hole from climbing into the air box. The curved outlet section of the Super-Scoop may be trimmed back if less bend is required to make a more streamlined hose routing.

37. Once a location has been determined for the Super-Scoop, mount it using one of the methods outlined below.

The Super-Scoop may be mounted by several means. If the grille consists of horizontal bars, or a perforated screen heavy enough to support it, the Super-Scoop may be secured using four 14" nylon cable ties slipped through the ears on the Super-Scoop and through the grille. See figure 7.

An alternate method is to mount the Super-Scoop using the four perforated metal straps provided. These can be bent as required, and attached to the ears with the $\frac{1}{4}$ "-20 x 1- $\frac{1}{4}$ " bolts, nylock nuts, and $\frac{3}{4}$ " OD x $\frac{5}{16}$ " ID flat washers provided. The other end of the brackets may be attached to any convenient mounting surface such as the gravel pan, grille brackets, etc. as required with #10 x $\frac{3}{4}$ " sheet metal

Figure 7

RAM-AIR SUPER-SCOOP MOUNTING METHODS

CABLE TIE MOUNTING

LOOP CABLE TIE THROUGH
TAB AND AROUND GRILLE,
PULL TAUT

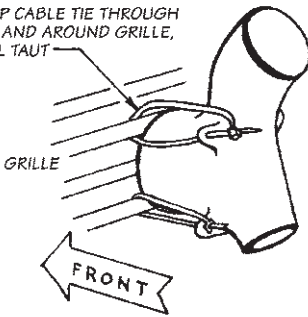

STRAP MOUNTING

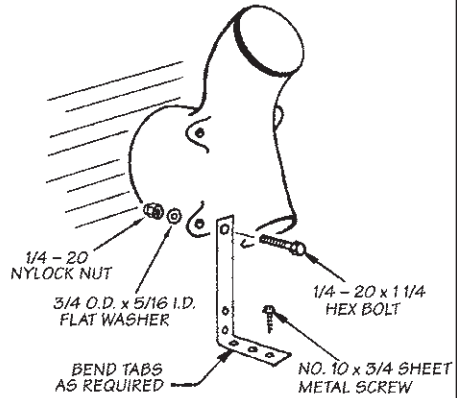

screws provided. A combination of cable ties and straps may also be used.

38. Connect the Super-Scoop to the hose connector using the 4" flexible hose provided. The hose may be shortened as needed. Secure the hose with two #64 hose clamps.

-END, SECTION 3-

Section 4

OTTOMIND INSTALLATION

39. Be certain battery ground cables have been disconnected.

40. Locate the engine control unit (ECU) under the dash mounted to the left hand side of the steering column. It will be housed in a black plastic case bolted to the column. Loosen the bolt attaching the electrical connector to the ECU. This will be pointing toward the floor of the coach.

41. Remove the bolts attaching the ECU to the bracket using a 1/4-inch drive 5.5mm socket and ratchet. A swivel and/or a 1/4-inch universal joint may be required to remove one or more bolts. Pull off the electrical connector and remove the plastic case and ECU from the vehicle.

42. Note the code printed on the plastic cap on the back of the ECU. This code should compare to the code

printed on the Banks OttoMind label. Pry the plastic cap from the rear of the ECU using a small screwdriver, exposing the printed circuit board edge connector inside. Retain the plastic cap. The connector will be coated with grease and a clear silicone type coating, which must be completely removed before installing the Banks OttoMind engine calibration module.

43. Using a 5.5mm nut driver, loosen and remove the six bolts that hold the case of the ECU together. Open the case of the ECU, being careful not to lose the plastic spacer or damage any circuitry inside the ECU.

44. Clean BOTH sides of the connector. First, clean the white grease off with a tissue. Next, scrape the clear silicone type coating from the connector fingers with the abrasive

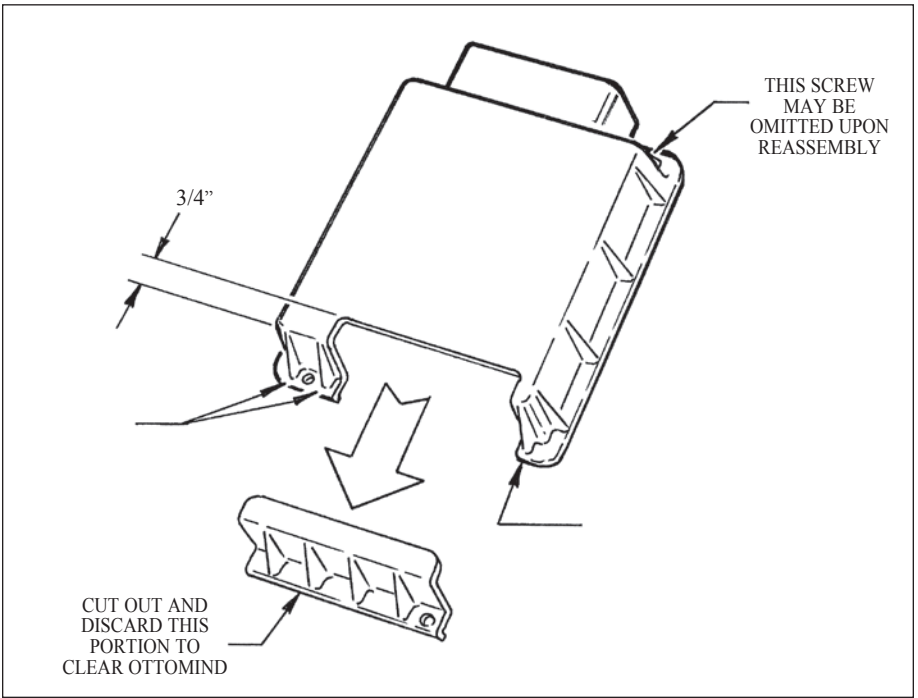

square provided. It is very important to clean both sides of the board in order to have a good connection between the ECU and the Banks OttoMind module. It is only necessary to clean the connector fingers. Be careful not to damage any circuit traces on the board further inside the ECU. Reassemble the ECU case and tighten the screw.

45. Orient the module so that its edges line up with the edges of the ECU case. If the edges do not line up, the module is rotated 180 degrees off. Place the OttoMind module over the connector, and press firmly to set the connection. DO NOT FORCE the OttoMind onto the connector, as damage may result to either the ECU or the module. If the module does not

install with firm pressure, check the orientation and try again.

46. A portion of the black plastic case must be cut away to provide clearance for the Ottomind module. Using figure 8 as a guide, cut away the portion of the case between the first rib on the right side and second rib on the left side, 3/4-inch in from the corner as shown. A band saw or hack saw works well for this job. Deburr the edges and reinstall the ECU in the plastic case, then reinstall ECU and case in the vehicle. The one corner screw shown may be omitted, as it is very difficult to reinstall. Reattach the electrical connector to the ECU and tighten the retaining bolt.

-END, SECTION 4-

Bill of Materials

FIG.#1	COMPONENT	GIT-KIT	STINGER	POWERPACK
1	TORQUETUBE, Left	-	-	✓
2	TORQUETUBE, Right	-	-	✓
3	Y-PIPE	-	-	✓
4	Y-PIPE EXTENSION	-	-	✓
5	DYNAFLOW MUFFLER	✓	✓	✓
6	MONSTER TAILPIPE	✓	✓	✓
7	TAIL PIPE TIP	✓	✓	✓
8	OTTOMIND (Optional)	-	✓	✓
9	SUPER-SCOOP	-	✓	✓
10	HOSE, Air duct 4" x 5'	-	✓	✓
11	CONNECTOR, Ram-Air Hose	-	✓	✓
12	HOUSING, Air Filter	-	✓	✓
13	AIR FILTER ELEMENT	-	✓	✓
14	AIR INLET TUBE	-	✓	✓
15	HEAT SHIELD, Starter	-	-	✓
16	HEAT SHIELD, Valve Cover	-	-	✓
17	HEAT SHIELD, Tail Pipe Extension	✓	✓	✓
18	HEAT SHIELD, Blanket	-	-	✓
19	HANGER, Exhaust (Right Exit Only)	✓	✓	✓
20	(4) MOUNTING STRAP	-	✓	✓

Bill of Materials

FIG.#1	COMPONENT	GIT-KIT	STINGER	POWERPACK
21	(3) CLAMP, Exhaust, 3½" HD	✓	✓	✓
22	CLAMP, Exhaust, 3" HD	✓	✓	✓
23	CLAMP, Exhaust, 2½" HD	-	-	✓
24	(3) HOSE CLAMP, #64	-	✓	✓
25	HOSE CLAMP, #52	-	-	✓
26	(2) CONICAL SEAL, Exhaust Outlet	-	-	✓
27	GASKET, TorqueTube	-	-	✓
28	GASKET, Catalytic Converter	-	-	✓
29	(4) BOLT, ⅜" 16 x 1¼" Hex	-	-	✓
30	(2) BOLT, ⅝" 18 x 1¼" Hex (Right Exit Only)	✓	✓	✓
31	(4) BOLT, ¼" 20 x 1¼" Hex	-	✓	✓
32	(2) NUT, ⅝" 18 Nylock (Right Exit Only)	✓	✓	✓
33	(4) NUT, ¼" 20 Nylock	-	✓	✓
34	(1) Hanger Clamp	✓	✓	✓
35	(20) BOLT, 8mm x 1.25 x 30mm	-	-	✓
36	BOLT, 6mm x 1.00 x 25mm	-	-	✓
37	(4) WASHER, ⅜" SAE (Right Exit Only, except PowerPack)	✓	✓	✓
37	(8) WASHER, ⅜" SAE (Right Exit Only)	-	-	✓
38	(4) WASHER, ¼" USS	-	✓	✓
39	WASHER, Metric 6mm	-	-	✓
40	SPACER, Manifold Bolt	-	-	✓
41	(4) SCREW, #10 x ¾"	-	✓	✓
42	(2) WIRE EXTENSION, O ₂ Sensor	-	-	✓
43	(5) WIRE TIES	-	-	✓
	(4) CABLE TIES, 15"	-	✓	✓
44	(10) CABLE TIES, 8"	-	✓	✓
45	(1) Intermediate Pipe W/Heatshield	✓	✓	✓
	KIT, Service, Ram-Air	-	✓	✓
	ANTI-SEIZE, 1oz	-	-	✓
	POLISH, Metal, 3 Grams	✓	✓	✓
	OWNERS MANUAL	✓	✓	✓
	(3) UROCAL, "Banks Power"	-	-	✓
	(2) DECAL, "Banks Power", Large	✓	✓	-
	(2) DECAL, "Banks Power", Small	✓	✓	-
	WARRANTY STATEMENT	✓	✓	✓
	CARD, Product Registration	✓	✓	✓

Notes

Notes

Notes

Gale Banks Engineering
546 Duggan Avenue • Azusa, CA 91702
(626) 969-9600 • Fax (626) 334-1743

Product Information & Sales: (800) 438-7693

bankspower.com
