

banks[®]

with Installation Instructions

Owner's Manual

Banks Monster[®] Exhaust System

**2004-08 Ford/Lincoln
F-150/Mark-LT (4.2L, 4.6L & 5.4L)
New Body Style (Non-Heritage models)**

THIS MANUAL IS FOR USE WITH SYSTEMS 48739-48743

Gale Banks Engineering
546 Duggan Avenue • Azusa, CA 91702
(626) 969-9600 • Fax (626) 334-1743

Product Information & Sales: (800) 438-7693

bankspower.com

Dear Customer,

If you have any questions concerning the installation of your Banks Power System, please call our Technical Service Hotline at (888) 839-2700 between 7:00 am and 5:00 pm (PT). If you have any questions relating to shipping or billing, please contact our Customer Service Department at (888) 839-5600.

Thank you.

General Installation Practices

1. Before starting work, familiarize yourself with the installation procedure by reading all of the instructions.
2. The exploded view (**Figure 1**) provides only general guidance. Refer to each step and section diagram in this manual for proper instruction.
3. Throughout this manual, the left side of the vehicle refers to the driver's side, and the right side to the passenger's side.
4. Disconnect the negative (ground) cable from the battery (or batteries, if there are two) before beginning work.
5. Route and tie wires and hoses a minimum of 6" away from exhaust heat, moving parts and sharp edges. Clearance of 8" or more is recommended where possible.
6. When raising the vehicle, support it on properly weight-rated safety stands, ramps or a commercial hoist. Follow the manufacturer's safety precautions. Take care to balance the

vehicle to prevent it from slipping or falling. When using ramps, be sure the front wheels are centered squarely on the topsides. When raising the front of the vehicle, put the transmission in park, set the parking brake, and block the rear wheels. When raising the back of the vehicle, be sure the vehicle is on level ground and the front wheels are blocked securely.

Caution! Do not use floor jacks to support the vehicle while working under it. Do not raise the vehicle onto concrete blocks, masonry or any other item not intended specifically for this use.

7. During installation, keep the work area clean. Do not allow anything to be dropped into intake, exhaust, or lubrication system components while performing the installation, as foreign objects will cause immediate engine damage upon start-up.

Tools Required:

- 1/2" and 3/8" drive ratchets with standard and metric sockets and 1/2" and 3/8" drive extension
- Standard and metric combination or open-end wrenches
- Standard screwdriver
- Clean shop towels or rags
- Pry-bar

Highly recommended tools and supplies:

- Foot-pound torque wrench
- Penetrating oil or light lubricant spray

Figure 1, General Assembly Diagram

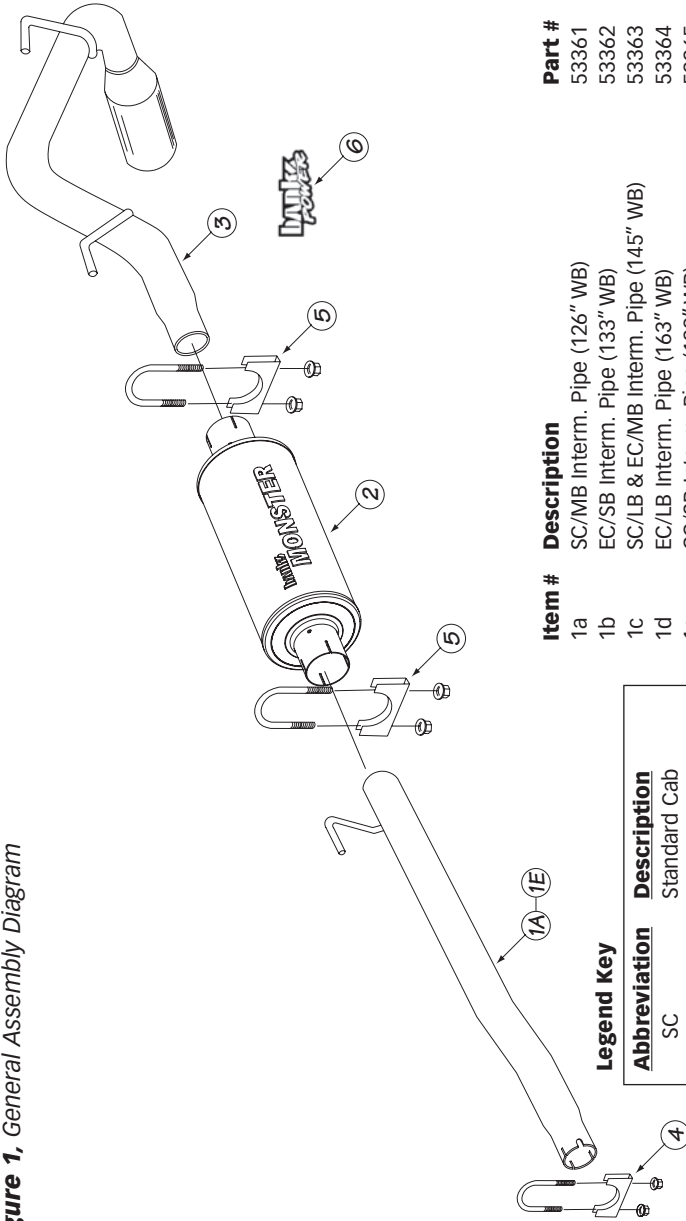

Item #	Description	Part #	QTY
1a	SC/MB Interm. Pipe (126" WB)	53361	1
1b	EC/SB Interm. Pipe (133" WB)	53362	1
1c	SC/LB & EC/MB Interm. Pipe (145" WB)	53363	1
1d	EC/LB Interm. Pipe (163" WB)	53364	1
1e	CC/SB Interm. Pipe (139" WB)	53365	1
2	Muffler	53958	1
3	Tailpipe	53367	1
4	Clamp, 2.50"	52461	1
5	Clamp, 3"	52465	2
6	Banks Uroicals	96009	2

Legend Key

Abbreviation	Description
SC	Standard Cab
EC	Extended Cab
CC	Crew Cab
SB	Short Bed (5 1/2')
MB	Medium Bed (6 1/2')
LB	Long Bed (8')

Monster Exhaust System Installation

1. Disconnect the negative (ground) cable from the battery (if there is more than one battery, disconnect both negative cables). Secure the cable so it cannot accidentally come in contact with the post.

2. Raise the vehicle and support it securely with properly weight-rated safety stands, ramps or a commercial hoist. Take care to balance the vehicle to prevent it from slipping or falling. When using ramps, be sure the wheels are centered squarely on the topsides. Place the transmission in park (automatic), set the parking brake and securely block the wheels

that are on the ground. **CAUTION: DO NOT WORK UNDER ANY VEHICLE SUPPORTED ONLY BY A JACK. SEVERE INJURY MAY RESULT.**

3. From under the vehicle remove the factory exhaust starting at the rear of the muffler. Remove the tailpipe by removing and retaining the two (2) M8x1.25 bolts supporting the rear tailpipe hanger. Remove and retain the rear rubber hanger from the tailpipe (see **Figure 2**).

4. Loosen the factory band clamp at the front of the muffler. Using spray lubricant, lube the front and rear muffler hanger pins. Remove the muffler and tailpipe assembly from the vehicle (see **Figure 3**).

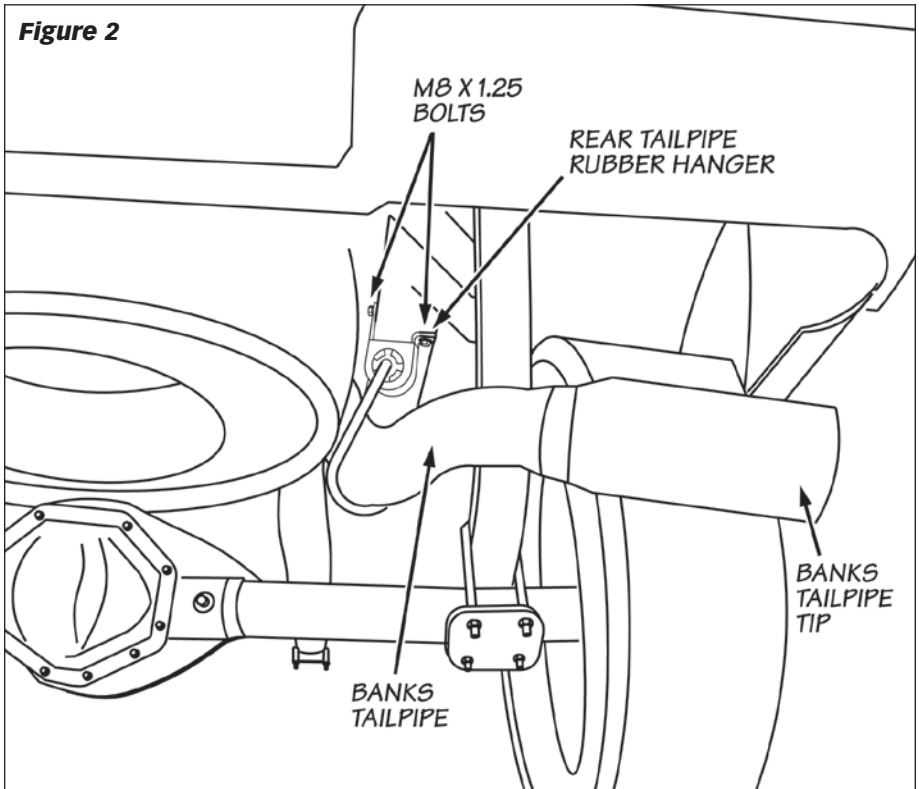

NOTE: Removing the rubber hangers from the vehicle may assist in exhaust removal.

5. If applicable, loosen the factory band clamp on the intermediate pipe. Using spray lubricant, lube the intermediate pipe hanger pins and remove the intermediate pipe from the vehicle.

6. *FOR SC/MB AND EC/SB MODELS ONLY.* Due to the enormous weight reduction of the Banks Exhaust system, the factory muffler front rubber hanger will be removed for Std. Cab Medium (6.5') Bed and Ext. Cab Short (5.5') Bed models. Remove the factory M8x1.25 bolt on the rubber muffler hanger, and remove the rubber hanger from the vehicle (see **Figure 3**).

7. Install a 2½" clamp onto the inlet of the Banks intermediate pipe. Install the Banks intermediate pipe to the factory Y-pipe outlet. Orient the pipe onto the locating pin and lightly tighten the 2½" clamp (see **Figure 4**).

8. Install a 3" clamp onto the muffler inlet. Install the Banks Muffler inlet (*Note the inlet labeling of the muffler*)

onto the intermediate pipe and lightly tighten the 3" clamp.

9. Install a 3" clamp on the Banks Muffler outlet. From the vehicle rear, route the tailpipe over the rear end. Start the front tailpipe hanger pin into the corresponding vehicle rubber hanger. Install tailpipe into the Banks Muffler Outlet (see **Figure 5**).

NOTE: Install the rubber hanger pins to the vehicle frame if previously removed.

10. Install the rear factory rubber hanger onto the rear tailpipe hanger pin. Reinstall the two (2) factory M8x1.25 bolts through the rubber hanger into the vehicle frame (see **Figure 2**).

11. Adjust the tip about ½"-1" under the body panel, such that the position is aesthetically pleasing.

12. With the exhaust positioned properly, begin to tighten the clamps and hardware starting with the ones closest to the front of the vehicle and working your way back. Torque the exhaust clamps evenly to 35 ft-lbs. Make sure that each slip is fully

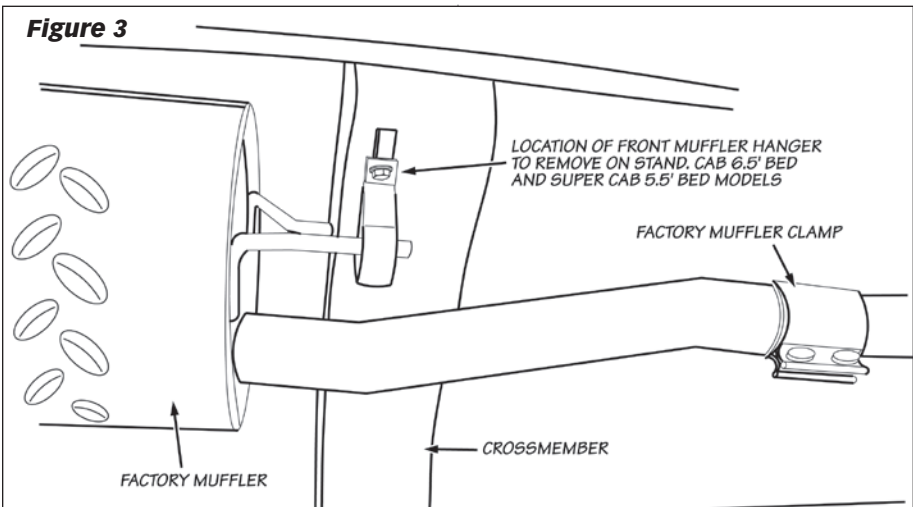
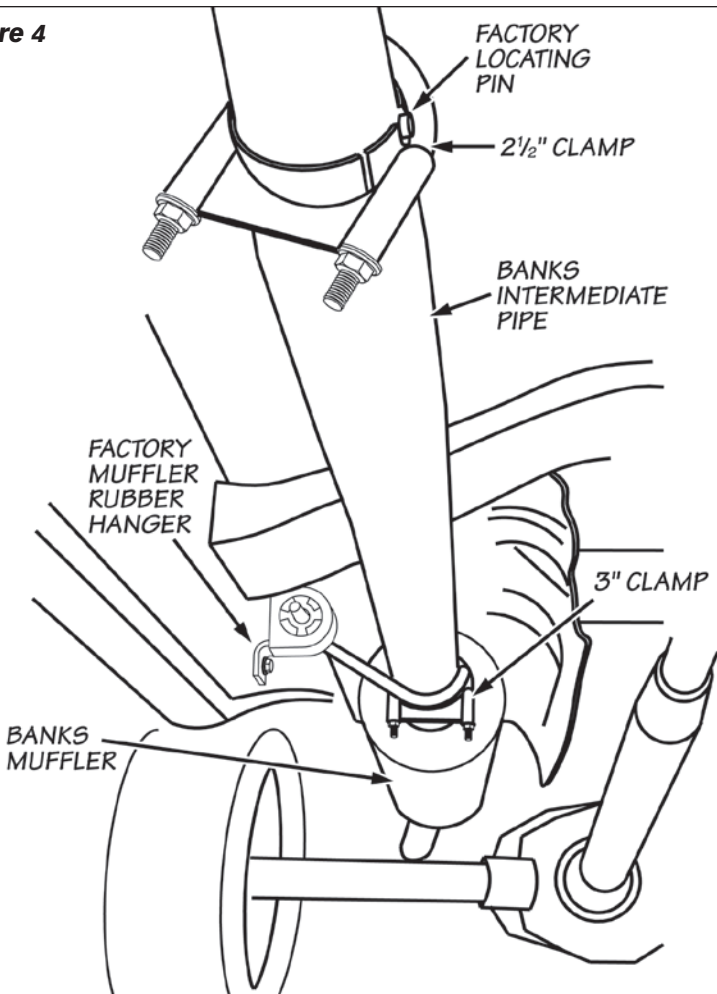

Figure 4



inserted (+/-1/4"). Torque the factory M8 hardware to 22 ft-lbs.

13. Remove the protective covering from the tailpipe tip. **Caution: the protective covering may ignite and burn if not removed prior to running the engine.**

14. Your system includes two (2) "Banks Power" logos designed to complement the Ford emblems on

the vehicles front fenders. Use the provided measurements for a clean factory look (see **Figure 6**).

15. Re-connect the negative battery cable. Start the engine and listen for exhaust leaks. Tighten the exhaust clamps as necessary. Whenever possible, tack weld slip connections to prevent disengagement is recommended. The Banks Monster Exhaust installation is now complete.

Figure 5

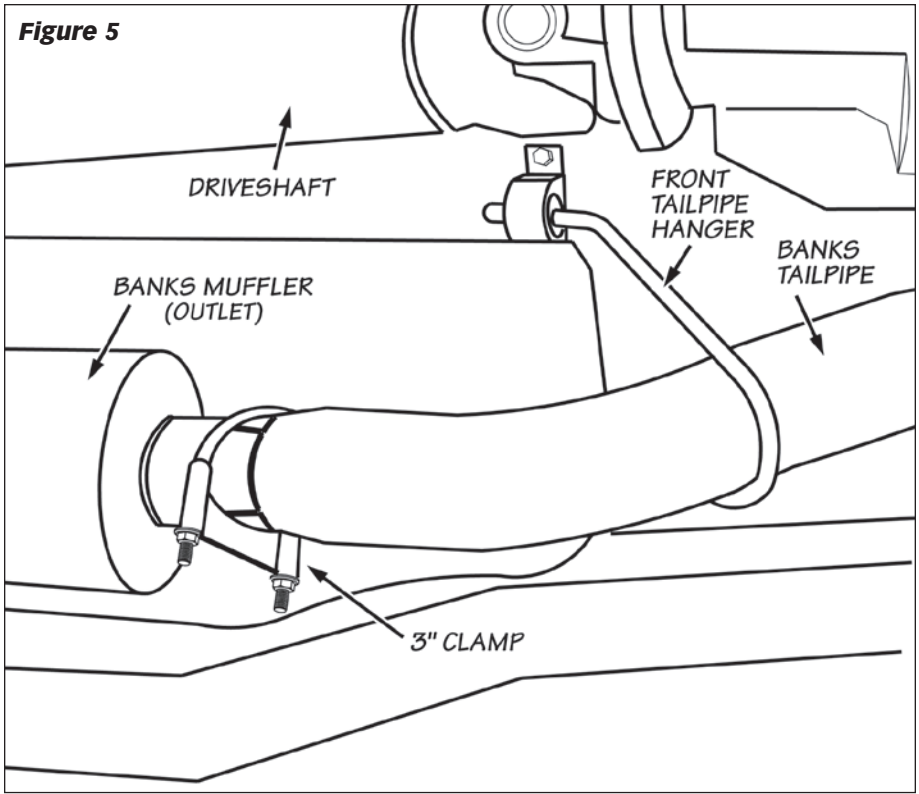
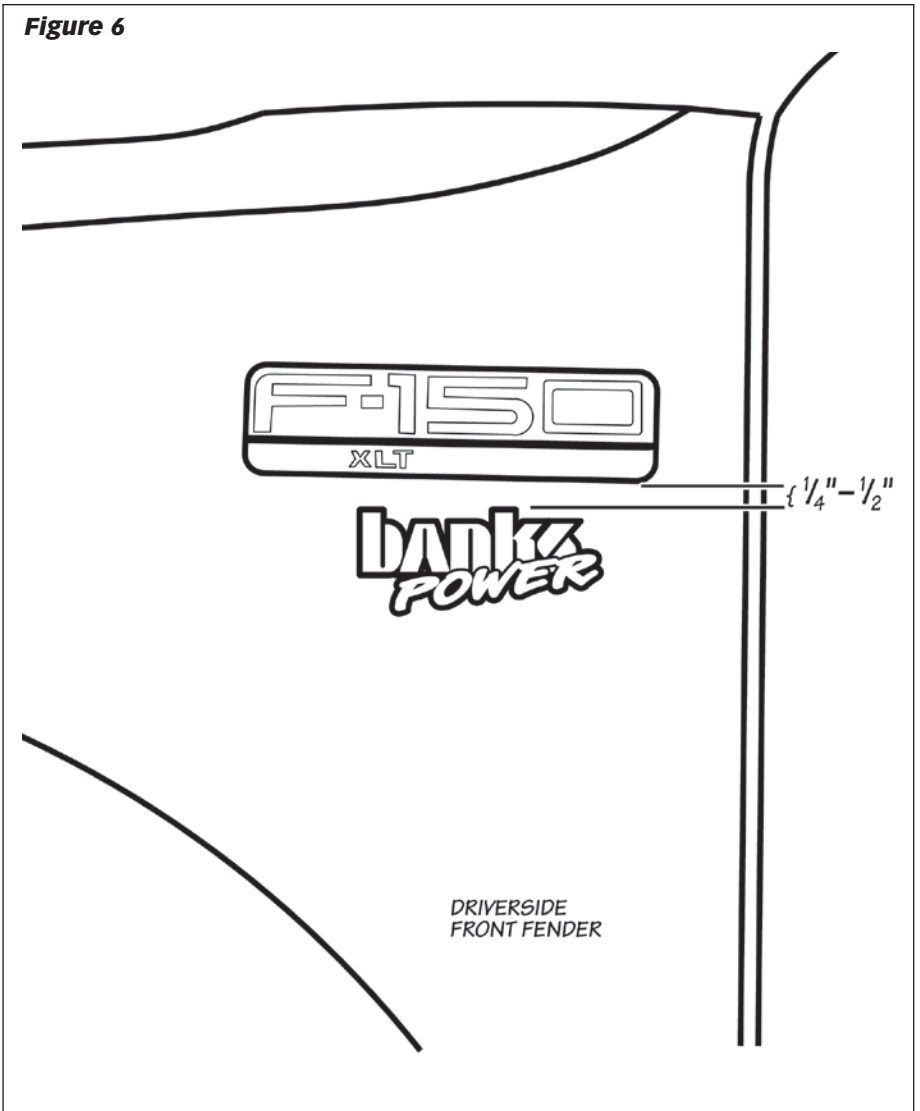

Figure 6



Gale Banks Engineering
546 Duggan Avenue • Azusa, CA 91702
(626) 969-9600 • Fax (626) 334-1743

Product Information & Sales: (800) 438-7693

bankspower.com