

# **OWNERS MANUAL**

**WITH INSTALLATION  
INSTRUCTIONS**

# **banks<sup>®</sup>**

# **TRANSCOMMAND<sup>®</sup>**

**TRANSMISSION COMMAND MODULE**

**FORD E40D/4R100 AUTOMATIC TRANSMISSION  
EQUIPPED VEHICLES**

THIS MANUAL IS FOR USE WITH SYSTEM **62560 & 62570**

**banks<sup>®</sup>**

GALE BANKS ENGINEERING

546 DUGGAN AVENUE • AZUSA, CA 91702

(626) 969-9600 • FAX (626) 334-1743

[www.bankspower.com](http://www.bankspower.com)

# **Attention TransCommand® Owner**

*Congratulations on your decision to protect your investment and get the most from your truck or RV! This note has been included to provide you with information concerning the Banks TransCommand on your vehicle.*

*While the Ford E4OD and 4R100 transmissions offer a smooth and comfortable shift, in many cases a more positive shift is necessary. If the vehicle is used to carry moderate loads, used for towing, or modified to increase power, such as through turbocharging, excess clutch slippage will result which can cause damage to the transmission.*

*The Banks TransCommand increases clutch pressure to reduce slip-time thereby providing a positive shift which extends the life of the transmission. The amount of TransCommand effect is dependent upon throttle position, engine RPM and mile per hour. The TransCommand, in conjunction with the Ford computer, is fully automatic in sensing load conditions. The more load sensed, the more the TransCommand will increase the line pressure on the clutches.*

*Included with the Banks TransCommand is a TransCommand bypass plug (see figure). By unplugging the TransCommand from the wire loom and inserting the bypass plug in its place, the vehicle can be returned to the factory transmission control functions. This is helpful during diagnostic and service work when it may be desirable to isolate the TransCommand from the system. The vehicle should not be operated without the TransCommand or bypass plug connected.*

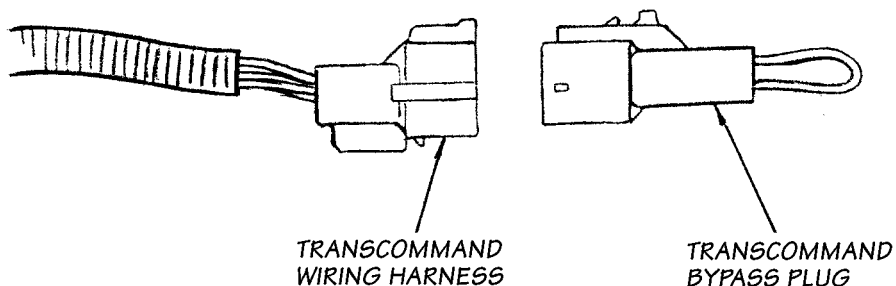

# GENERAL INSTALLATION PRACTICES

- 1.** For ease of installation of your Banks TransCommand®, familiarize yourself with the procedure by reading the entire manual before starting work.
- 2.** The exploded views provide only general guidance. Refer to each step and section diagram in this manual for proper instruction.
- 3.** Throughout this manual, the driver's side of the vehicle refers to the left side, and the passenger's side to the right side.
- 4.** During installation of the TransCommand, be sure that the ignition key is in the off position.
- 5.** Route and tie wires and hoses a minimum of 6 inches away from exhaust heat, moving parts and sharp edges. Clearance of 8 inches or more is recommended where possible.

- 6.** When raising the vehicle, support it on properly weight-rated safety stands, ramps or a commercial hoist. Follow the manufacturer's safety precautions. Take care to balance the vehicle to prevent it from slipping or falling. When using ramps, be sure the front wheels are centered squarely on the topsides; put the transmission in park; set the hand brake; and place blocks behind the rear wheels. **CAUTION! Do not use floor jacks to support the vehicle while working under it. Do not raise the vehicle onto concrete blocks, masonry or any other item not intended specifically for this use.**
- 7.** During installation, keep the work area clean. If foreign debris is transferred to any Banks component, clean it thoroughly before installing.

**FIGURE 1**

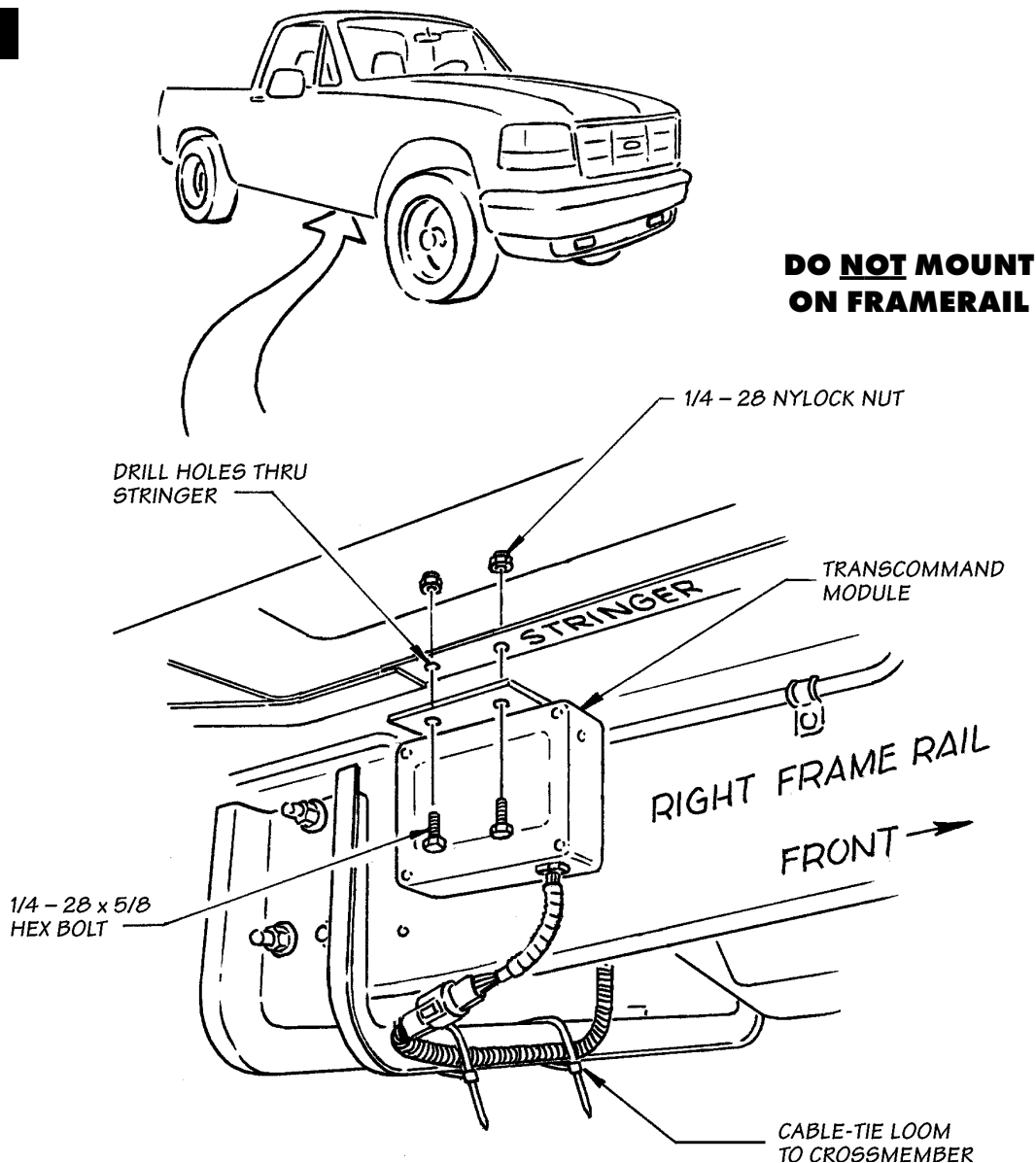

# INSTALLATION PROCEDURE

**1.** Raise the front of vehicle on ramps, jack stands, or a lift if available. DO NOT WORK UNDER ANY VEHICLE SUPPORTED ONLY BY A JACK!

**2.** Locate the body reinforcement stringer running parallel to and outside of the frame rail under the passenger side of the vehicle. Now, locate the crossmember which is supporting the rear of the transmission. The TransCommand™ will be mounted to the stringer just slightly forward of the crossmember. See Figure 1. DO NOT mount the TransCommand™ to the frame rail, as it may become hot.

**3.** Using the TransCommand™ mounting bracket as a template, mark drilling locations on the stringer. Drill two mounting holes using a  $\frac{9}{32}$ " drill.

*NOTE: On some vehicles it may be necessary to mount the TransCommand™ to the body next to the frame rail. In this case, mark drilling locations using the TransCommand™ bracket as a template and drill two mounting holes using a  $\frac{3}{16}$ " drill.*

**4.** Using two  $\frac{1}{4}$ -28 x  $\frac{5}{8}$ " bolts and two  $\frac{1}{4}$ -28 nylock nuts, mount the TransCommand™ to the body reinforcement stringer as shown in Figure 1.

*NOTE: On vehicles where the TransCommand will mount to the body next to the frame rail, mount the TransCommand using two  $\frac{1}{4}$ " dia. x  $\frac{5}{8}$ " sheet metal screws provided.*

**5.** Identify the factory transmission control wiring harness on the right (passenger) side of the transmission. See Figure 2. Disconnect this wiring harness by pressing on the retaining tab on the outside of the connector near the top and pulling the connector upward.

*NOTE: On vehicles equipped with an E40D, this plug is located behind the small metal shield. Using an 8mm wrench, unbolt this shield to reveal the plug. On vehicles equipped with a 4R100, it may be necessary to unbolt the exhaust heat shielding and slide it out of the way to access the plug. (There is no small metal shield.)*

**6.** Using a slim pair of needle-nose pliers, or a hemostat clamp, remove the red plastic wedge from between the two rows of pin sockets in the transmission control wiring harness connector. On 1995 and later models, the pins are held in place with a red retainer. Remove the retainer by placing a small screwdriver tip between the connector shell and the retainer and prying the retainer out. See Figure 3.

**7.** Using Figure 3 as a guide, identify the pin locations in the transmission control wiring connector.

**IMPORTANT: Make a diagram showing the wire colors of pins 1, 11, and 12. Write them down on Figure 3. These colors vary with the vehicle year and must be hooked to the proper connections in later steps. NOTE: If wire color of pins 1 & 12 are both red, mark/tape the pin-12 wire, for later identification.**

**8.** Reach in through the front of the connector with a small screwdriver or sharp scribe; gently move the locking tang away from pin No. 1 and remove the wire and pin socket from the back side of the connector body. Repeat for pin socket No. 11. Repeat for pin socket No. 12.

**9.** Using Figures 3 and 4 as a guide, insert three female socket/wire ends from the Banks TransCommand™ harness into the factory transmission control wiring connector body as follows:

**FIGURE 2**

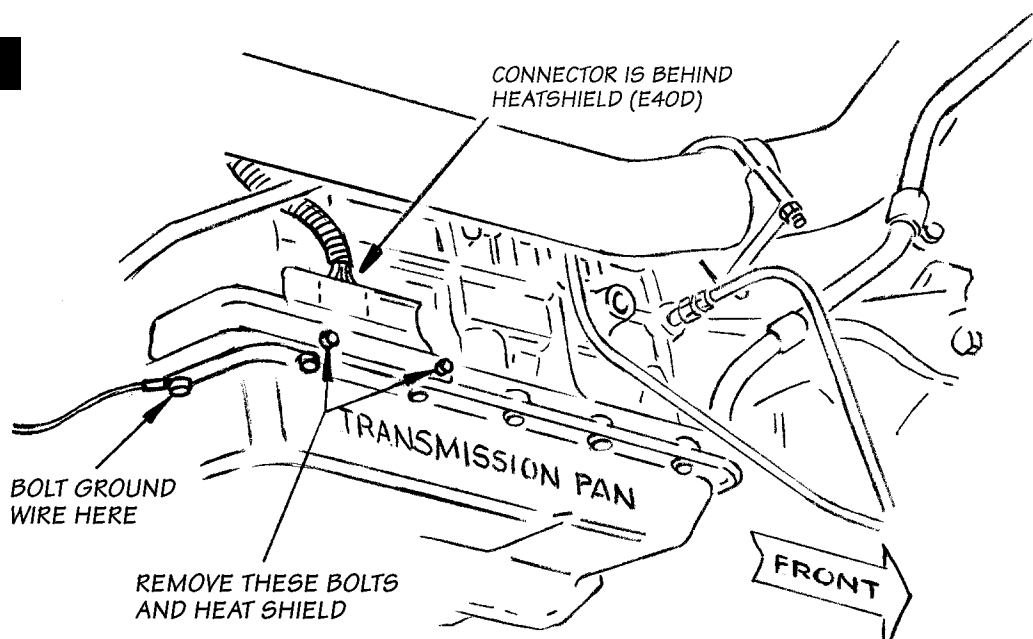

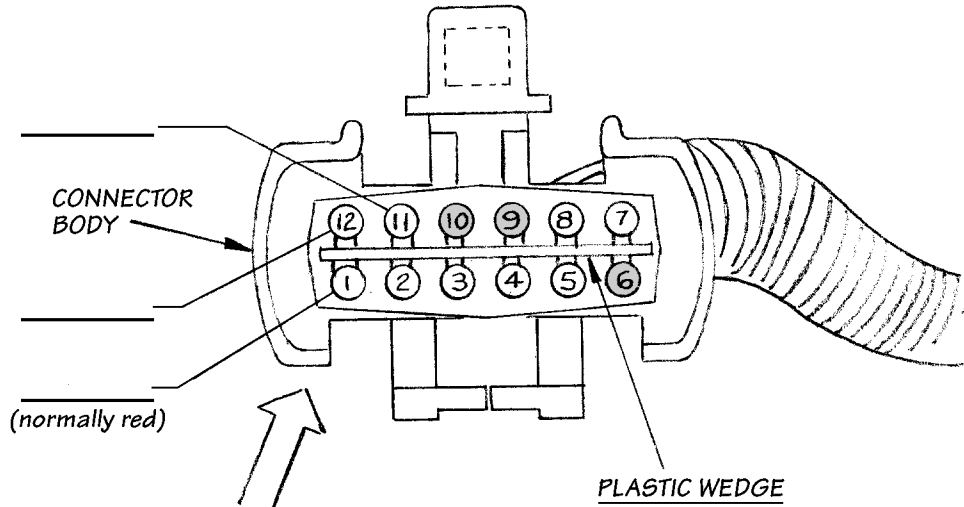
**FIGURE 3****FRONT VIEW  
1994 & EARLIER****IMPORTANT!**

MAKE A NOTE OF THE WIRE COLORS FOR PINS 1, 11 and 12 ON EITHER STYLE OF CONNECTOR BEFORE REMOVING WIRES FROM CONNECTOR BODY

REMOVE BY GRASPING WITH SLIM NEEDLE-NOSE PLIERS OR HEMOSTAT. OR, PULL OUT WITH A STIFF PIECE OF WIRE WITH A SMALL HOOK ON THE END.

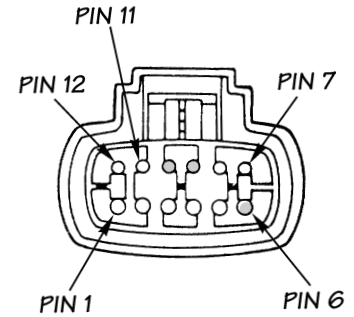
**FRONT VIEW  
1995 & LATER**

**NOTE:**  
PINS 1-6 ARE CLOSEST TO TRANSMISSION.  
PINS 6, 9 & 10 ARE EMPTY.

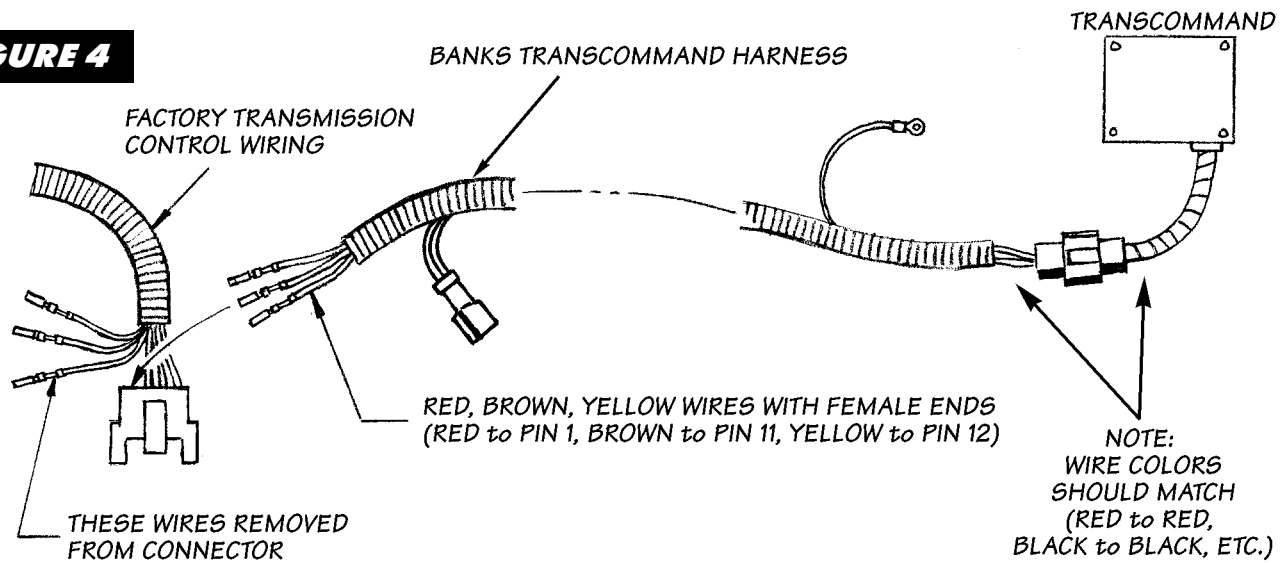
**FIGURE 4**

- A.** Insert the red wire with the female socket into pin 1 location of the connector. The locking tang should click into place when the female socket is fully seated.
- B.** Insert the brown wire with the female socket into pin 11.
- C.** Insert the yellow wire with the female socket into pin 12.

**10.** Reinstall the red plastic wedge or retainer (removed in step 6) between the two rows of socket pins in the connector body.

**11.** Locate the supplied round four pin connector shell pictured in Figure 5. Remove the red wedge from front of

the connector. Using Figures 3 and 5 as a guide, insert the three wires that were removed from the transmission connector in steps 6 through 8 into the back of the connector shell. Be sure to refer to the wire colors that were noted on Figure 3.

- A.** Insert the wire that was removed from pin No. 1 into the pin No. 1 hole of the shell shown in Figure 5. Be sure pin clicks into place.
- B.** Insert the wire from pin No. 11 into the pin No. 2 hole.
- C.** Insert the wire from pin No. 12 into the pin No. 3 hole.

*NOTE: Pin No. 4 hole is not used.*

**FIGURE 5**

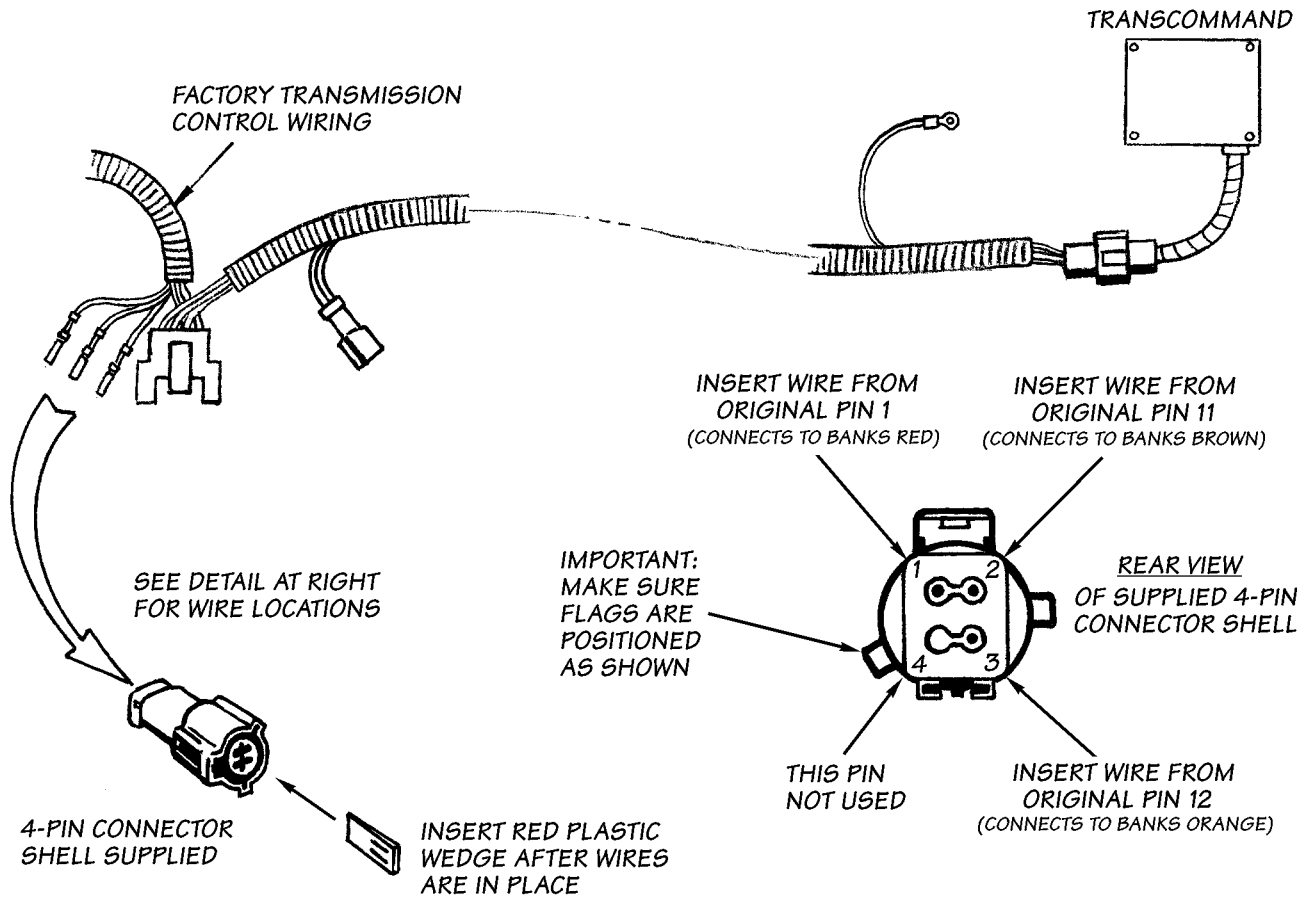

**12.** Insert the thin end of the supplied red plastic wedge into the front of the connector.

**13.** Inspect the new connector assembly by double checking the wire colors and pulling on the wires from the rear of the connector to be sure they are fully seated.

**14.** Plug the new connector into its mate on the Banks TransCommand harness.

**15.** Reconnect the transmission control wiring connector to the transmission.

*NOTE: If the connector doesn't "snap" into position easily it is possible that the rubber seal that is supposed to be around the Ford wire loom connector has come off the plug and is down the transmission socket. If this has happened, remove the seal with a small pick and slide it over the red retainer and try again.*

Reinstall the heat shield.

**16.** Route TransCommand™ harness along the transmission crossmember and under the frame as shown in Figure 1. Plug the TransCommand™ wiring harness into the pigtail connector on the TransCommand™.

**17.** Using a 10mm socket, remove the right rear transmission pan bolt. Insert the bolt through the ring terminal on the end of the black ground wire and reinstall it in the transmission. See Figure 2.

**18.** Go over the entire installation, check that all wiring is properly secured. The Banks TransCommand™ installation is now complete. Lower the vehicle.

*NOTE: The following symptoms would indicate a wiring error. If the "Check Engine" light (or Over Drive indicator light) flashes, or the transmission appears to have third gear only, or very harsh shifting occurs, check the following. Be sure the wiring is correct, the pins are all fully seated in the connectors and the connectors are fully mated.*

# ***TROUBLESHOOTING TIPS***

Over 90% of problems that occur with TransCommands are related to wiring problems.

## **SYMPTOMS**

- Normal shifts (no increased pressure)
- Very hard shifts
- Blinking OD light (which doubles as a check engine light)
- The “limp-home” mode (The limp-home mode gives a two speed transmission: second gear in low or second and third gear in drive. The vehicle must be manually shifted from low to drive.)

## **POSSIBLE SOLUTIONS**

- 1.** Verify that the correct wires have been removed from the transmission connector.
- 2.** Check that these wires have been inserted into the correct TransCommand socket cavities.
- 3.** Sometimes, the pins have not been fully inserted into the connectors. This can usually be observed by looking into the face of the connector and verifying that all the pins are flush with the rest of the pins while pulling on the wire at the back of the connector.
- 4.** Although it is extremely rare, there have been some TransCommand wire looms that have been assembled incorrectly. Verify that the colors of the wires match between the eight pin connectors (red to red, yellow to yellow, etc.). Also, check the colors of the four pin connector against what is indicated in the instructions.

The only electrical failure that can be diagnosed without returning the unit to GBE is to measure the resistance between the orange and yellow wires of the TransCommand with an ohm meter. This should measure one ohm. Slightly higher readings will be noted due to ohm meter lead resistance. (Note: All returns must be accompanied with a Return Merchandise Authorization number obtained from GBE.)

The only component the TransCommand is connected to in the transmission is the Electronic Pressure Valve. Symptoms such as early or late shifts, torque convertor clutch engagement problems or early overdrive disengagement have nothing to do with the TransCommand.

# BILL OF MATERIALS

## TransCommand

<b>COMPONENT</b>	<b>62560</b>	<b>62570</b>
MODULE, TransCommand E40D <i>p/n 62560</i>	✓	-
MODULE, TransCommand 4R100 <i>p/n 62570</i>	-	✓
HARNESS, Wire with connector shell and wedge <i>p/n 62519</i>	✓	✓
PLUG, Bypass Connector 8 pin <i>p/n 62512</i>	✓	✓
(2) BOLT, 1/4" 28 x 5/8" Hex <i>p/n 91137</i>	✓	✓
(2) NUT, 1/4" 28 Nylock <i>p/n 91111</i>	✓	✓
(2) SCREW, Sheet Metal, #14 x 5/8" Hex WSHR head <i>p/n 91848</i>	✓	✓
(3) TIE, Cable, 5" Black <i>p/n 62001</i>	✓	✓
(2) TIE, Cable, 15" Black <i>p/n 62003</i>	✓	✓
WARRANTY STATEMENT <i>p/n 96362</i>	✓	✓