

banks

with Installation Instructions

Owner's Manual

Banks Monster[®] Exhaust System

2005-06 Ford 6.8L (V-10) and 5.4L (V-8) F-Super Duty Owners Manual

THIS MANUAL IS FOR USE WITH MONSTER EXHAUST SYSTEMS 48724

Gale Banks Engineering
546 Duggan Avenue • Azusa, CA 91702
(626) 969-9600 • Fax (626) 334-1743

Product Information & Sales: (800) 438-7693
Customer Support: (888) 839-5600
Installation Support: (888) 839-2700

bankspower.com

Dear Customer,

If you have any questions concerning the installation of your Banks Monster Exhaust System, please call our Technical Service Hotline at (888) 839-2700 between 7:00 am and 5:00 pm (PT). If you have any questions relating to shipping or billing, please contact our Customer Service Department at (888) 839-5600.

Thank you.

General Installation Practices

1. Before starting work, familiarize yourself with the installation procedure by reading all of the instructions.
2. The exploded view (**Figure 1**) provides only general guidance. Refer to each step and section diagram in this manual for proper instruction.
3. Throughout this manual, the left side of the vehicle refers to the driver's side, and the right side to the passenger's side.
4. Disconnect the negative (ground) cable from the battery (or batteries, if there are two) before beginning work.
5. Route and tie wires and hoses a minimum of 6" away from exhaust heat, moving parts and sharp edges. Clearance of 8" or more is recommended where possible.

6. When raising the vehicle, support it on properly weight-rated safety stands, ramps or a commercial hoist. Follow the manufacturer's safety precautions. Take care to balance the vehicle to prevent it from slipping or falling. When using ramps, be sure the front wheels are centered squarely on the topsides; put the transmission in park; set the hand brake, and place blocks behind the rear wheels.

Caution! Do not use floor jacks to support the vehicle while working under it. Do not raise the vehicle onto concrete blocks, masonry or any other item not intended specifically for this use.

7. During installation, keep the work area clean. Do not allow anything to be dropped into intake, exhaust, or lubrication system components while performing the installation, as foreign objects will cause immediate engine damage upon start-up.

Tools Required:

- 1/2" and 3/8" drive ratchets with standard and metric sockets and 1/2" and 3/8" drive extension
- Standard and metric combination or open-end wrenches
- Standard screwdriver
- Clean shop towels or rags
- Pry-bar

Highly recommended tools and supplies:

- Foot-pound torque wrench
- Penetrating oil or light lubricant spray

Figure 1 General assembly diagram

Item #	Description	Part #	QTY
1	Clamp, 3"	52465	1
2	Intermediate Pipe	53139	1
3	Hanger Clamp, Front	53140	1
4	Monster 3.5" Muffler	54008	1
5	Hanger Clamp, Rear	53141	1
6	Tailpipe	53142	1
7	Banks Urocalcs	96009	2

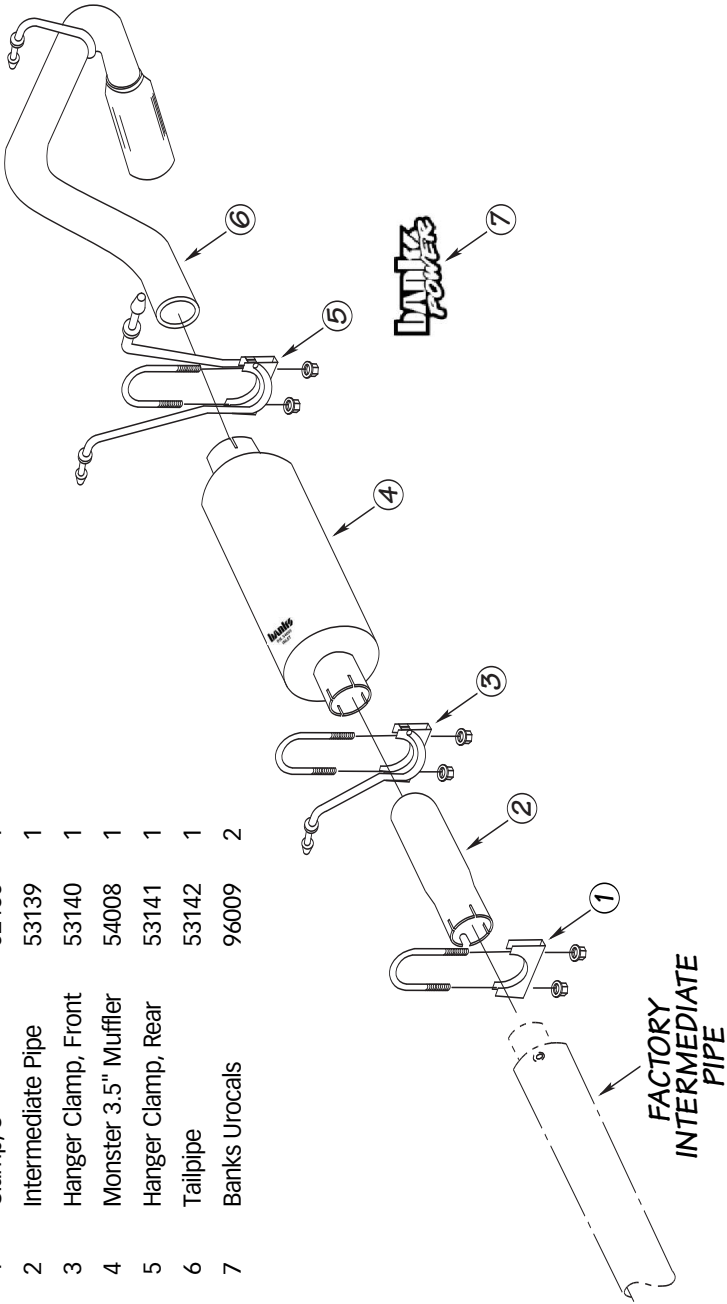

Monster Exhaust System Installation

1. Disconnect the negative (ground) cable from the battery (if there is more than one battery, disconnect both negative cables). Secure the cable so it cannot accidentally come in contact with the post.

2. Raise the vehicle and support it securely with properly weight-rated safety stands, ramps or a commercial hoist. Take care to balance the vehicle to prevent it from slipping or falling. When using ramps, be sure the wheels are centered squarely on the topsides. Place the transmission in park (automatic), set the parking brake and securely block the wheels that are on the ground. **CAUTION: DO NOT WORK UNDER ANY VEHICLE SUPPORTED ONLY BY A JACK. SEVERE INJURY MAY RESULT.**

3. From under the vehicle remove the factory exhaust starting at the front of the muffler. Remove the factory muffler and tailpipe assembly by removing the factory band clamp on the muffler to intermediate pipe connection.

NOTE: Spray lubricant may assist in hanger pin removal.

4. Remove the factory front muffler hanger pin from the rubber grommet.

Remove the factory tailpipe hanger pin from the rubber grommet. Supporting the tailpipe, remove the dual rear muffler hanger pins from the rubber grommets. Remove the factory muffler and tailpipe assembly from the vehicle.

5. Install the supplied 3" clamp onto the inlet of the Banks intermediate pipe. Install the Banks intermediate pipe to the factory intermediate pipe outlet. Align the locating pin notch onto the intermediate pipe. Lightly tighten the 3" clamp (see **Figure 2**).

NOTE: All clamps should be positioned at the beginning of the slots (on the 1/2 circle punch) and evenly tightened.

6. Install the front muffler hanger clamp onto the outlet of the intermediate pipe. Insert the hanger clamp pin into the rubber grommet. Install the inlet of the Banks Monster Muffler (note the muffler inlet labeling) onto the intermediate pipe and lightly tighten the front hanger clamp (see **Figure 2**).

7. Install the rear muffler dual hanger clamp onto the Banks Muffler outlet such that the hanger pins are facing forward. Install the two (2) clamp hanger pins into the corresponding vehicle rubber grommets.

Figure 2

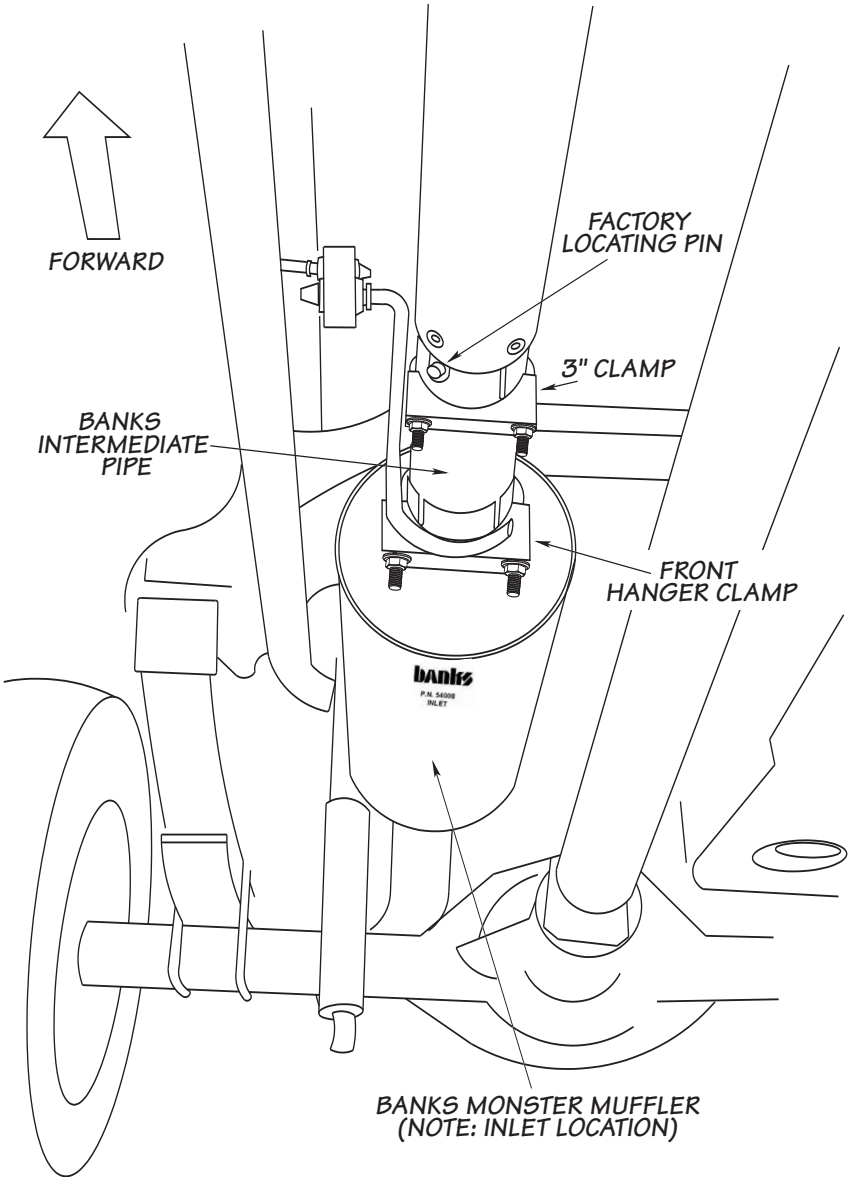

8. From the vehicle rear, route the tailpipe over the rear end. Start the tailpipe hanger pin into the corresponding vehicle rubber hanger. Install the tailpipe into the Banks Muffler outlet. Lightly tighten the rear muffler hanger clamp to secure the tailpipe (see **Figure 3**).

9. Adjust the Tailpipe Tip 1" under the rear fender such that the tip position is aesthetically pleasing (see **Figure 3**).

10. With the exhaust positioned properly, begin to tighten the clamps starting with the ones closest to the front of the vehicle and working your way back. Torque the exhaust clamps evenly to 35 ft-lbs. Make sure that each slip is fully inserted (+/- 1/4").

All hanger pins should be facing forward (see **Figure 4**).

11. Remove the protective covering from the tailpipe tip. **Caution: the protective covering may ignite and burn if not removed prior to running the engine.**

12. Your system includes two (2) Banks Power logos designed to complement the Ford Factory emblems on the vehicles front doors.

13. Re-connect the negative battery cable. Start the engine and listen for exhaust leaks. Tighten the exhaust clamps as necessary. Whenever possible, tack weld slip connections to prevent disengagement it is recommended. The Banks Monster Exhaust installation is now complete.

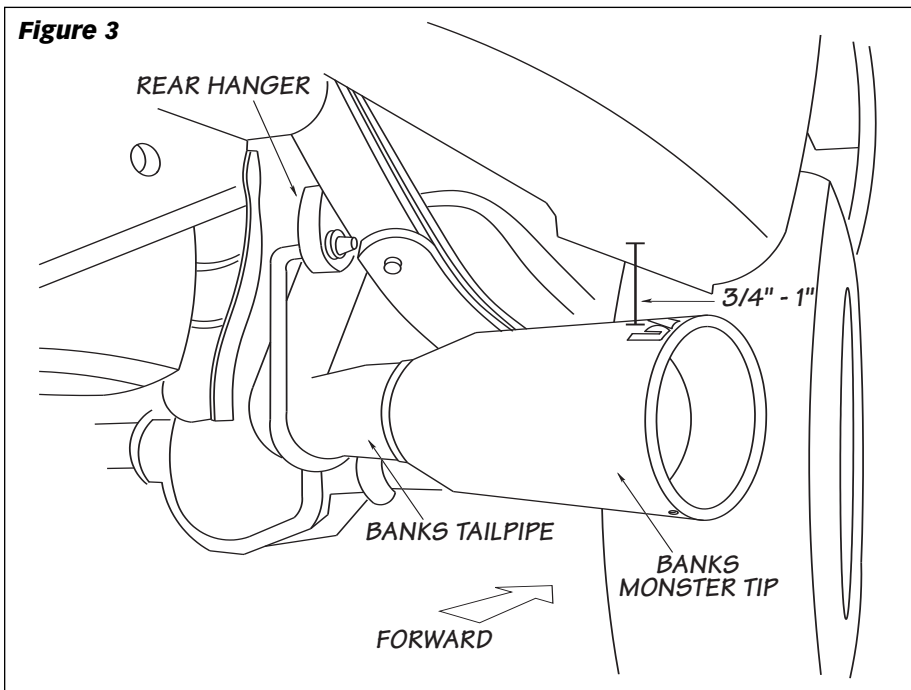
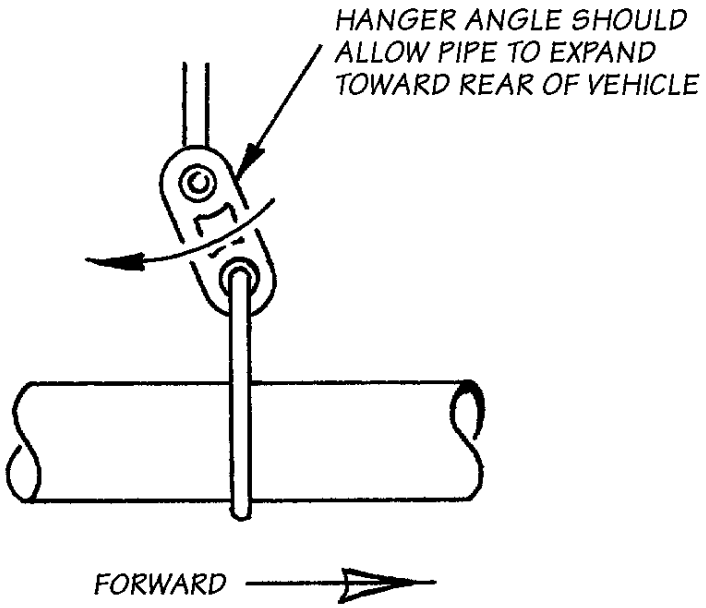

Figure 4



Gale Banks Engineering
546 Duggan Avenue • Azusa, CA 91702
(626) 969-9600 • Fax (626) 334-1743

Product Information & Sales: (800) 438-7693
Customer Support: (888) 839-5600
Installation Support: (888) 839-2700

bankspower.com